



SERVICE PARTS LIST

SPECIFY CATALOG NO. AND SERIAL NO. WHEN ORDERING PARTS		REVISED BULLETIN	DATE
1-1/2" (40mm) ROTARY HAMMER			Feb. 2007
CATALOG NO. 5319-21	STARTING SERIAL NO. 863A	WIRING INSTRUCTION 58-01-1850	

EXAMPLE:
 Component Parts (Small #) Are Included
 When Ordering The Assembly (Large #).

▲ SEE BACK PAGE OF THIS BULLETIN FOR ADDITIONAL LUBRICATION AND SERVICE NOTES

● = Component of the Hammer Service Kit No. 14-46-9265

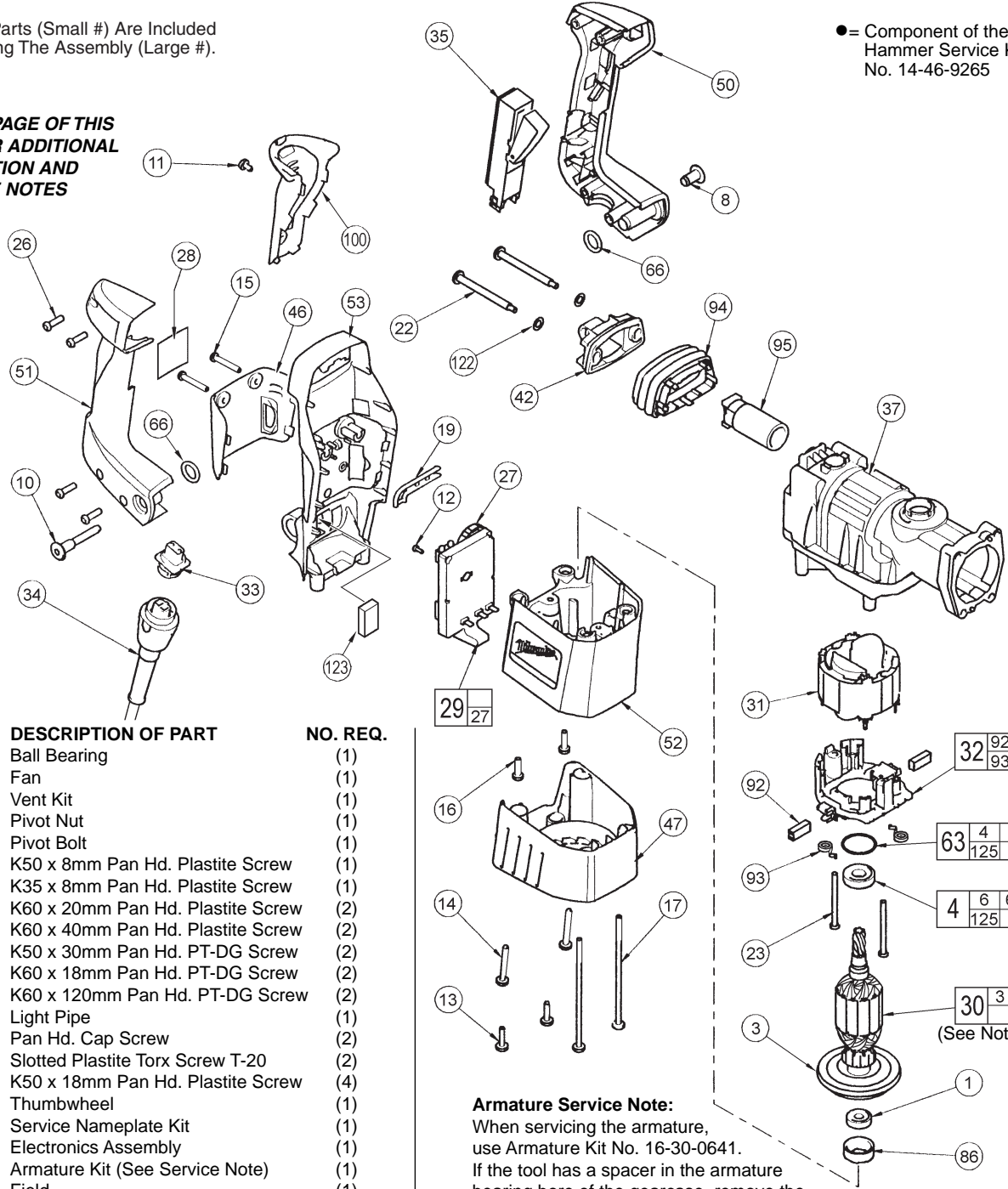
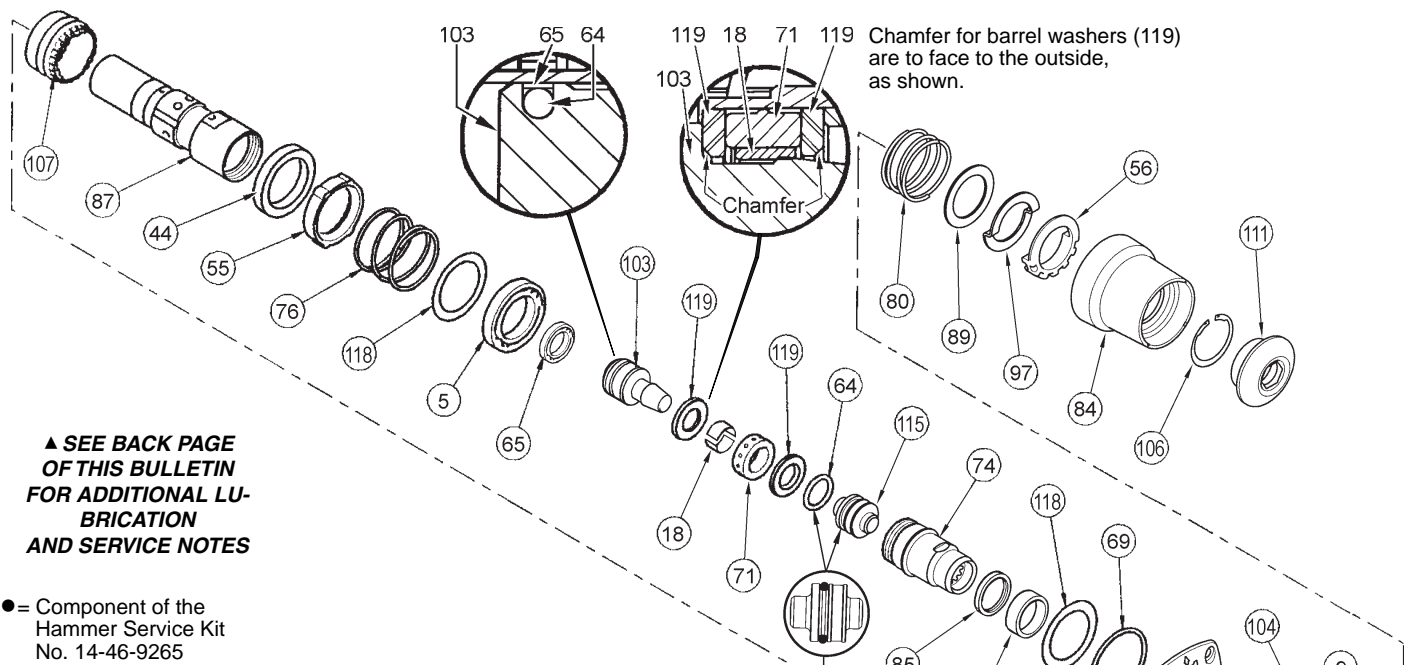

FIG.	PART NO.	DESCRIPTION OF PART	NO. REQ.
	1	Ball Bearing	(1)
	3	Fan	(1)
	4	Vent Kit	(1)
	8	Pivot Nut	(1)
	10	Pivot Bolt	(1)
	11	K50 x 8mm Pan Hd. Plastite Screw	(1)
	12	K35 x 8mm Pan Hd. Plastite Screw	(1)
	13	K60 x 20mm Pan Hd. Plastite Screw	(2)
	14	K60 x 40mm Pan Hd. Plastite Screw	(2)
	15	K50 x 30mm Pan Hd. PT-DG Screw	(2)
	16	K60 x 18mm Pan Hd. PT-DG Screw	(2)
	17	K60 x 120mm Pan Hd. PT-DG Screw	(2)
	19	Light Pipe	(1)
	22	Pan Hd. Cap Screw	(2)
	23	Slotted Plastite Torx Screw T-20	(2)
	26	K50 x 18mm Pan Hd. Plastite Screw	(4)
	27	Thumbwheel	(1)
	28	Service Nameplate Kit	(1)
	29	Electronics Assembly	(1)
	30	Armature Kit (See Service Note)	(1)
	31	Field	(1)
	32	Brush Card Assembly	(1)
	33	Blade Housing Assembly	(1)
	34	Quik-Lok Cord Set	(1)
	35	Switch	(1)
	37	Crankcase Assembly	(1)
	42	Upper Handle Mount	(1)
	46	Module Cover	(1)
	47	Motor Cover	(1)
	50	Left Handle Half	(1)
	51	Right Handle Half	(1)
	52	Motor Housing	(1)
	53	Rear Shroud	(1)
	63	Vent Kit	(1)
	66	O-Ring	(2)
	86	● Bearing Cup	(1)

Armature Service Note:

When servicing the armature, use Armature Kit No. 16-30-0641. If the tool has a spacer in the armature bearing bore of the gearcase, remove the spacer and install O-Ring No. 34-40-4215 into the empty groove. The O-Ring is provided in the kit.

FIG.	PART NO.	DESCRIPTION OF PART	NO. REQ.
	92	● Carbon Brush Kit (Includes 2 Brushes)	(1)
	93	Brush Spring	(2)
	94	Bellows	(1)
	95	Isolation Module Assembly	(1)
	100	Cushion Grip	(1)
	122	Rubber Washer	(2)
	123	Handle Seal	(1)
	23-94-0270	Leadwire Assembly	(2)



▲ SEE BACK PAGE OF THIS BULLETIN FOR ADDITIONAL LUBRICATION AND SERVICE NOTES

● = Component of the Hammer Service Kit No. 14-46-9265

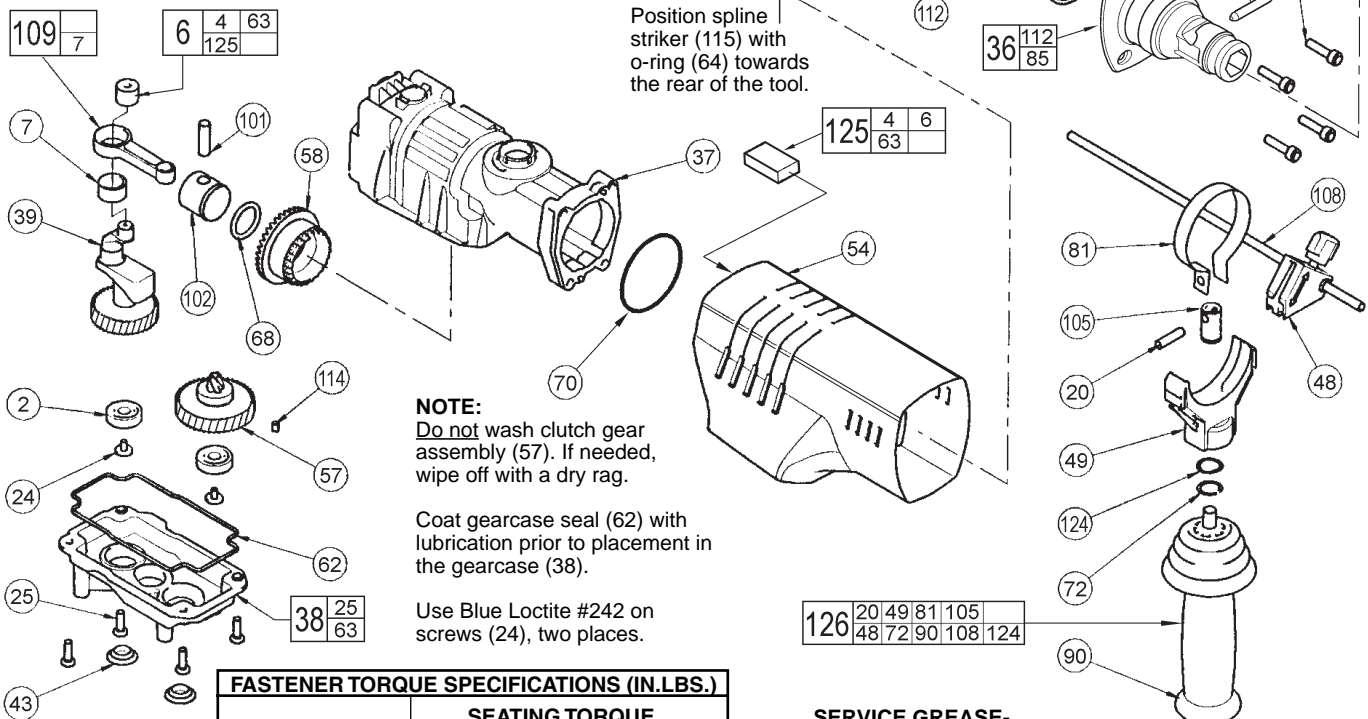

FASTENER TORQUE SPECIFICATIONS (IN.LBS.)

FIG. NO.	SEATING TORQUE	
	MINIMUM	MAXIMUM
9	120	140
10	20	25
11	3	6
12	4	8
13	20	25
14	20	25
15	15	20
16	50	55
17	30	35
22	30	35
23	12	17
24	20	25
25	45	50
26	15	20
74	130 FT. LBS.	200 FT. LBS.
87	130 FT. LBS.	200 FT. LBS.
Switch Screws	4	6

SERVICE GREASE-

● "S2" Grease, No. 49-08-5265 7 oz. tube

● 14-46-9265 HAMMER SERVICE KIT

THIS KIT CONTAINS:

- 2 31-12-0040 Cap Plug
- 1 34-40-0240 Gearcase Seal
- 2 34-40-4350 O-Ring
- 1 34-40-4475 Cap Seal
- 1 34-40-4215 O-Ring
- 1 34-40-4510 O-Ring
- 1 34-40-4530 O-Ring
- 1 34-40-4570 Damping Washer
- 1 42-96-0125 Bearing Cup
- 2 45-22-0680 Split Sleeve
- 1 22-18-1355 Carbon Brush Kit
- 1 49-08-5265 "S2" Grease, 7oz. Tube

● 22-18-1355 CARBON BRUSH SERVICE KIT

THIS KIT CONTAINS:

- 2 ----- Carbon Brush

FIG.	PART NO.	DESCRIPTION OF PART	NO. REQ.
2	02-04-0911	Ball Bearing	(2)
5	02-08-0640	Ball Bearing	(1)
6	14-46-0040	Vent Kit	(1)
7	02-50-4020	Needle Bearing	(1)
9	05-74-0625	M6 Socket Head Cap Screw	(4)
18	45-22-0680	● Sleeve	(2)
20	06-65-1660	Dowel Pin	(1)
24	06-82-8842	Slotted Taptite Torx Screw	(2)
25	05-88-9910	K50 x 22mm PT-DG Screw	(4)
36	14-46-1980	Spline Nose Kit	(1)
37	28-14-2543	Crankcase Assembly	(1)
38	14-46-2565	Gearcase Service Kit	(1)
39	14-09-0160	Crankshaft Assembly	(1)
43	31-12-0040	● 5/8 Cap Plug	(2)
44	31-58-0160	Lock Ring Spacer	(1)
48	14-34-0551	Depth Rod Mount Assembly	(1)
49	31-44-2010	Side Handle Housing	(1)
54	31-55-0311	Main Shroud	(1)
55	31-58-0150	Locking Ring	(1)
56	31-86-0225	Spacer	(1)
57	14-08-0200	Clutch Gear Assembly	(1)
58	32-30-0060	Drive Gear	(1)
62	34-40-0240	● Gearcase Seal	(1)
64	34-40-4350	● O-Ring	(2)
65	34-40-4475	● Capseal	(1)
68	34-40-4510	● O-Ring	(1)
69	34-40-4520	O-Ring	(1)
70	34-40-4530	● O-Ring	(1)
71	34-40-4570	● Damping Washer	(1)
72	34-60-2580	External Retaining Ring	(1)
74	38-50-6300	Spline Driver	(1)
76	40-50-0380	Compression Spring	(1)
80	40-50-0360	Compression Spring	(1)
81	42-16-0155	Side Handle Band	(1)
84	42-76-0740	Chuck Collar	(1)
85	45-06-0560	Oil Seal	(1)
87	42-98-0260	Barrel	(1)
89	45-88-1380	Bitlock Washer	(1)
90	14-34-0516	Side Handle Assembly	(1)
97	45-88-1070	Stepped Washer	(1)
101	44-60-1710	Wrist Pin	(1)
102	44-62-0230	Piston	(1)
103	44-82-0220	Ram	(1)
104	44-60-1640	Bitlock Pin	(1)
105	44-86-0620	Band Retainer	(1)
106	34-60-2590	Retaining Ring	(1)
107	44-90-0175	Shift Ring	(1)
108	44-94-0165	Depth Gauge Rod	(1)
109	44-94-0395	Connecting Rod Assembly	(1)
111	45-06-0040	Dust Seal	(1)
112	45-88-5176	Felt Seal	(1)
114	45-30-0060	Retaining Slug	(1)
115	45-56-2570	Spline Striker	(1)
118	45-88-1565	Washer	(2)
119	45-88-4005	Barrel Washer	(2)
124	45-88-8730	Wave Washer	(1)
125	14-46-0040	Vent Kit	(1)
126	14-34-0585	Side Handle Assy Kit	(1)

NOTE: Check the clutch torque. Clutch must slip at 40 to 50 ft.lbs. at the spindle, checked clockwise as viewed from the front of the tool.

▲ SEE BACK PAGE OF THIS BULLETIN FOR ADDITIONAL LUBRICATION AND SERVICE NOTES

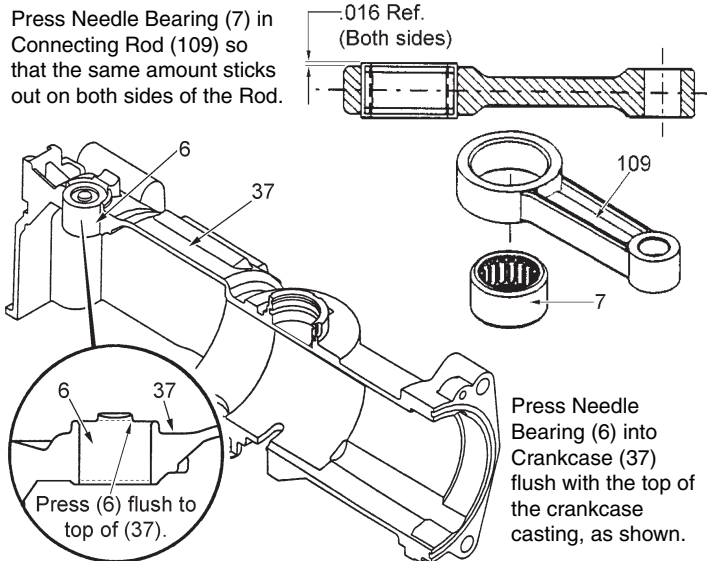

LUBRICATION NOTES: (TYPE "S2" GREASE, NO. 49-08-5265)

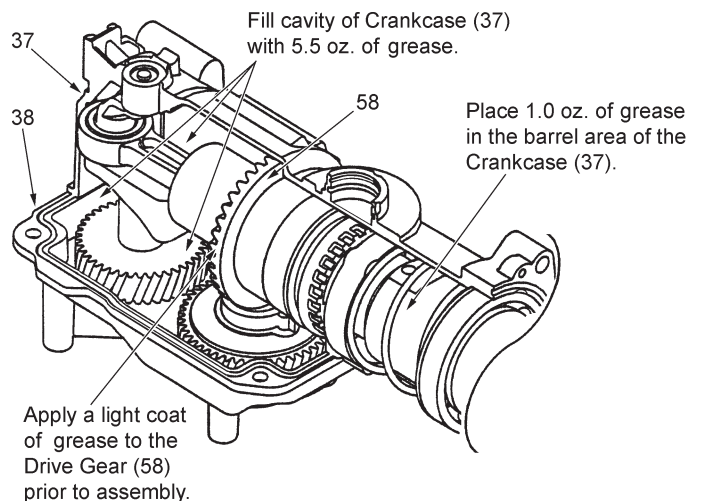
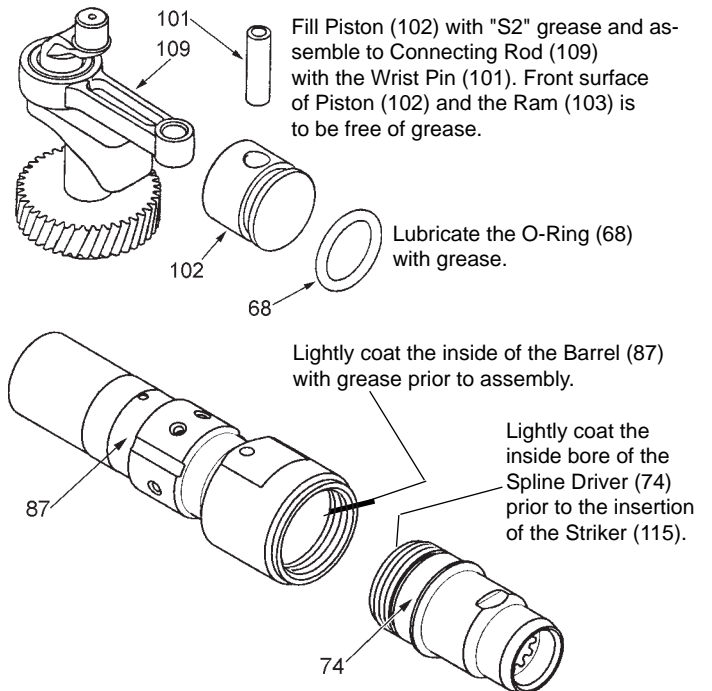

Prior to assembly, apply a light coat of grease to the Gearcase Seal (62) and O-Rings (63, 64, 67, 68 and 70).

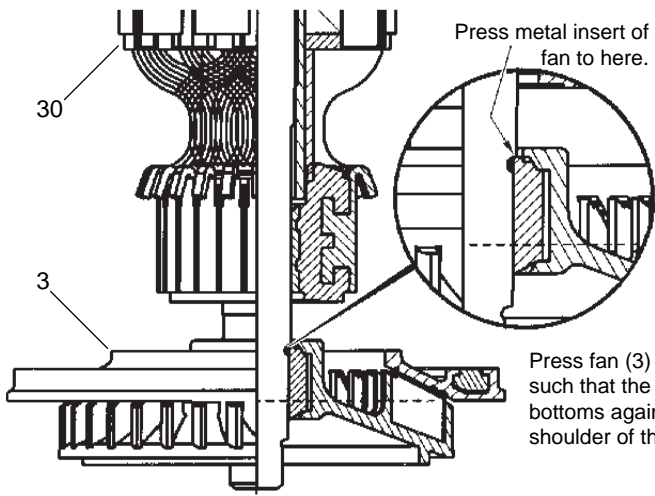

Press metal insert of fan to here.

Press fan (3) onto armature (30) such that the metal insert of the fan bottoms against the fan journal shoulder of the armature shaft.

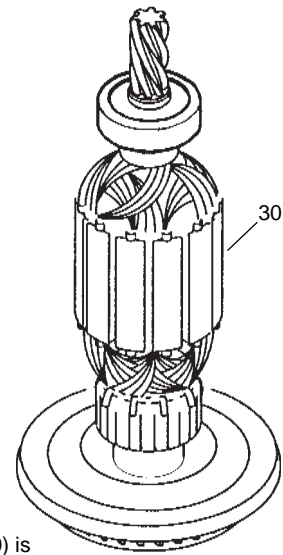

After the armature assembly (30) is installed into the tool, the bearing cup (86) is to be placed on the rear armature bearing (1), (already pressed onto the armature shaft), prior to assembling the motor cover (47) to the tool.

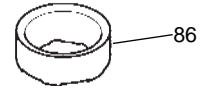
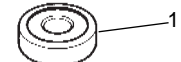

NOTE: Do not dislodge the bearing cup from the bearing during assembly.