



# SERVICE PARTS LIST

**BULLETIN NO.**  
**54-24-0302**

SPECIFY CATALOG NO. AND SERIAL NO. WHEN ORDERING PARTS		REVISED BULLETIN	DATE
1-1/2" ROTARY HAMMER		54-24-0301	Mar. '97
CATALOG NO. 5341	STARTING SERIAL NO. 776B	WIRING INSTRUCTION	
		58-01-0734	

**EXAMPLE:**

Component Parts (Small #) Are Included  
When Ordering The Assembly (Large #).

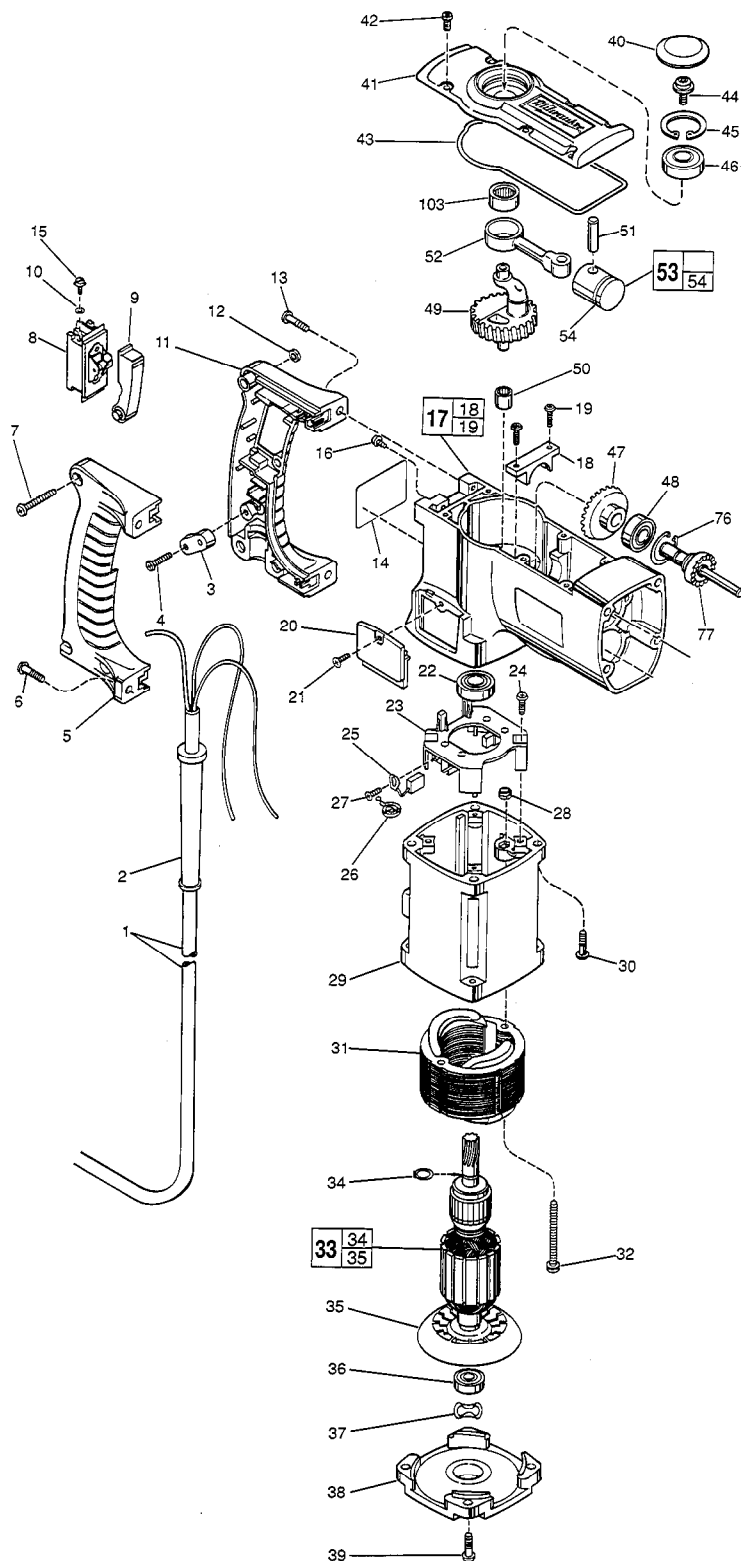

FIG.	PART NO.	DESCRIPTION OF PART	NO. REQ.
1	22-64-0121	Cord Set	(1)
2	44-76-0050	Cord Protector	(1)
3	31-17-0180	Cord Clamp	(1)
4	05-78-0571	M4.55 x 1.59 x 19 Pan Hd. Screw	(2)
5	31-44-1620	Right Handle Half	(1)
6	05-78-0570	M4.55 x 1.59 x 16 Pan Hd. Screw	(2)
7	05-81-0650	M5 x .8 x 25 Pan Hd. Screw	(3)
8	23-66-1230	Switch	(1)
9	31-92-0230	Trigger	(1)
10	06-97-1800	No. 6 Int. Tooth Lockwasher	(4)
11	31-44-1610	Left Handle Half	(1)
12	05-55-0610	M5 x .8 Hex Nut	(3)
13	05-78-0665	M5 x .8 x 20 Pan Hd. Screw	(2)
14	12-20-0710	Service Nameplate Kit	(1)
15	06-95-0125	Switch Terminal Screw	(4)
16	05-88-8300	M4 x .7 x 10 Pan Hd. T-20 Ground Sc.	(1)
17	14-09-0125	Crankcase Assembly	(1)
18		Bearing Cap	(1)
19	05-78-0460	M4 x .7 x 16 Pan Hd. Screw	(2)
20	31-15-0250	Brush Cover	(2)
21	05-78-0440	M4 x .7 x 10 Pan Hd. Screw	(2)
22	02-04-1203	Ball Bearing	(1)
23	22-22-1450	Brush Carrier Assembly	(1)
24	05-78-0340	M3.63 x 1.34 x 10 Pan Hd. Screw	(2)
25	22-18-0780	Carbon Brush (2) Kit	(1)
26	23-52-1550	Brush Spring	(2)
27	05-78-0405	M4 x .7 x 10 Pan Hd. Screw	(2)
28	06-57-3005	10-32 Locking Hex Nut	(2)
29	31-50-0940	Motor Housing	(1)
30	05-74-0515	M5 x .8 x 20 Socket Hd. Sems	(4)
31	18-50-0151	120 Volt Field	(1)
32	06-81-7470	10-32 x 1-7/8 Pan Hd. Sems	(2)
33	16-50-0150	120 Volt Armature	(1)
34	34-60-0950	Retaining Ring	(1)
35	22-84-0710	Fan	(1)
36	02-04-0850	Ball Bearing	(1)
37	45-88-0577	Wave Washer	(1)
38	31-15-0270	Motor Housing Cover	(1)
39	05-78-0570	M4.55 x 1.59 x 16 Pan Hd. Screw	(4)
★ 40	31-12-0270	Cover Cap	(1)
★ 41	28-20-1350	Crank Case Cover	(1)
★ 42	05-88-3641	M4 x .7 x 16 Pan Hd. Screw T-20	(6)
★ 43	34-40-4325	Cover Seal	(1)
★ 44	06-82-8842	8-32 x 3/8" Pan Hd. Tapt. Sems T-20	(1)
★ 45	34-80-5090	Retaining Ring - Beveled	(1)
★ 46	02-04-0911	Ball Bearing	(1)
★ 47	32-05-1250	Bevel Gear	(1)
★ 48	02-04-1022	Ball Bearing	(1)
★ 49	14-09-0106	Crank Assembly	(1)
★ 50	02-50-1645	Needle Bearing	(1)
★ 51	44-60-1395	Wrist Pin	(1)
★ 52	44-94-0345	Connecting Rod	(1)
★ 53	14-46-5000	Piston Assembly	(1)
★ 54	34-40-4090	O-Ring	(1)
★ 76	34-80-2006	Internal Retaining Ring	(1)
★ 77	36-14-0700	Clutch Shaft	(1)
★ 103	02-50-4240	Needle Bearing	(1)
	10-98-6331	Product Label - Eagle	(2)

● 14-46-1194 1-1/2" HAMMER SERVICE KIT  
THIS KIT INCLUDES:

1	31-12-0270	Cover Cap
1	34-40-4085	O-Ring
2	34-40-4090	O-Ring
1	34-40-4095	O-Ring
1	34-40-4100	O-Ring
1	43-44-0670	Gasket
1	43-44-0920	Gasket
1	49-08-4230	5 Oz. Tube "N" Grease

**SEE REVERSE SIDE**

**MILWAUKEE ELECTRIC TOOL CORPORATION**  
13135 W. LISBON RD., BROOKFIELD, WI 53005

**FIG. NOTES:**

- 19,58 Apply Type 242 Blue Loctite. Torque To 30-35 In.-Lb.
- 36 Bearing Seal To Face Fan.
- 50 Press Flush To Bottom Of Bore (1.845 Deep).
- 69 Bearing To Be Pressed Flush To The Back Surface Of The Intermediate Housing. Bearing Vendor Name Or Number To Be Visible From Back Side.
- 71 Springs To Be Positioned With Discs Opposing Each Other, As Shown.
- 85 Apply Type 242 Blue Loctite and Torque To 120-140 In.-Lb.
- 113 .09 Dia. Hole To Be Positioned Downward.

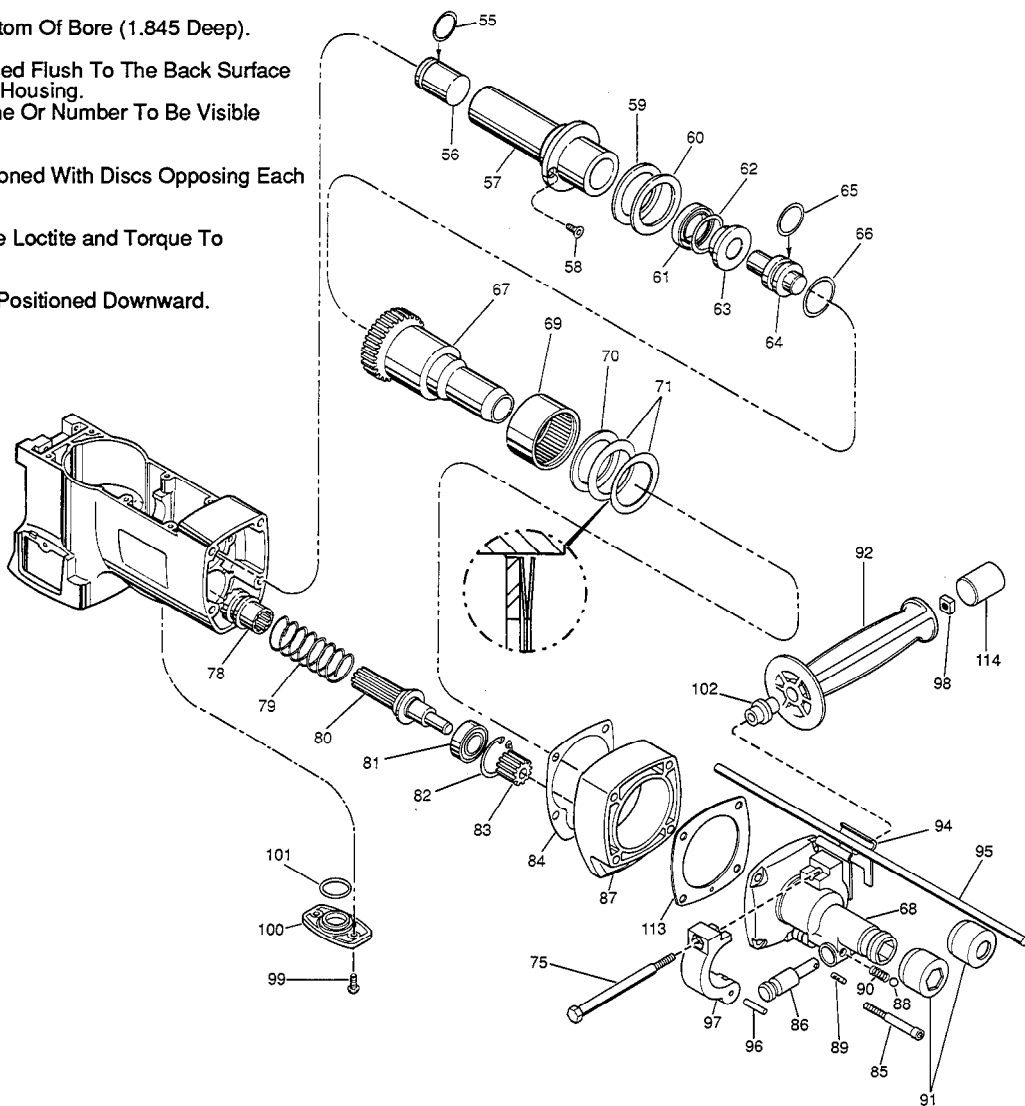

FIG.	PART NO.	DESCRIPTION OF PART	NO. REQ.
55	34-40-4090	● O-Ring	(1)
56	44-82-0102	Ram	(1)
57	42-98-0166	Service Barrel Assembly	(1)
58	05-78-0435	M4 x .7 x 13 Flat Hd. Taptite Screw	(2)
59	44-90-0562	Damping Ring - Plastic	(1)
60	45-88-7851	Thrust Washer - Steel	(1)
61	45-88-8015	Cushion Washer	(1)
62	34-40-4085	● O-Ring	(1)
63	45-88-8020	Cushion Washer	(1)
64	45-56-2551	Striker	(1)
65	34-40-4095	● O-Ring	(1)
66	34-40-4100	● O-Ring	(1)
67	38-50-5531	Spindle	(1)
68	14-52-0010	Nose Assembly	(1)
69	02-50-9976	Needle Bearing	(1)
70	45-88-0900	Thrust Washer	(1)
71	40-50-7850	Belleville Spring	(2)
★ 75	06-14-0020	3/8-16 x 4 Hex Hd. Bolt	(1)
78	36-14-0710	Splined Clutch	(1)
79	40-50-3250	Clutch Spring	(1)
80	14-08-0125	Splined Clutch Assembly	(1)
81	02-04-1510	Ball Bearing	(1)
82	34-80-2355	Internal Retaining Ring	(1)
83	32-60-2150	Pinion	(1)
84	43-44-0670	Gasket	(1)
85	05-74-0650	M6 x 1.0 x 50 Socket Hd. Cap Screw	(4)
86	44-20-0222	Bit Lock	(1)
87	28-14-2220	● Intermediate Housing	(1)
88	02-02-0250	1/4" Steel Ball	(1)
89	06-65-0828	Groove Pin	(1)

FIG.	PART NO.	DESCRIPTION OF PART	NO. REQ.
90	40-50-8420	Spring	(1)
91	45-06-0540	Dust Seal - Hex	(1)
	45-06-0550	Dust Seal - Round	(1)
92	43-62-0840	Side Handle	(1)
★ 94	45-60-0600	Depth Gage Clamp	(2)
95	44-94-0165	Depth Gage Rod	(1)
96	06-65-0631	Groove Pin	(1)
★ 97	28-82-0190	Handle Ring Half	(2)
★ 98	06-54-0310	Square Nut	(1)
99	05-78-0440	M4 x .7 x 10 Pan Hd. Screw	(2)
100	31-15-0410	Clutch Cover	(1)
101	34-40-4160	O-Ring	(1)
★ 102	45-36-1590	Spacer	(1)
113	43-44-0920	● Gasket	(1)
114	44-68-0560	Plug-Cap	(1)

**FIG. LUBRICATION**

- 49 2-1/2 Oz. Type "N" Grease, No. 49-08-4230.
- 53 Completely Fill Back Cavity Of Piston Before Assembly To Connecting Rod.
- 53,56 Piston And Ram Faces To Be Free Of Grease.
- 80 1-1/2 Oz. Type "N" Grease, No. 49-08-4230.
- 83 1 Oz. Type "N" Grease, No. 49-08-4230.
- Grease All Rubber Parts When Assembling .