

FASTENER TORQUE SPECIFICATIONS (IN.LBS.)

FIG. NO.	SEATING TORQUE		
	MINIMUM	MAXIMUM	
13	20	25	
14	120	140	
15	20	25	
16	30	35	
19	30	35	
20	25	30	
21	20	25	
22	20	25	
23	CRANKCASE COVER	25	30
24	HANDLE HALVES AND SHROUDS	15	20
	CUSHION GRIP	6	10
25		35	45
105		60	70

22-18-0870 CARBON BRUSH SERVICE KIT

THIS KIT CONTAINS:

- 2 ----- Carbon Brush

14-46-9065 HAMMER SERVICE KIT

THIS KIT CONTAINS:

- 1 31-12-0270 Cap-Cover
- 1 34-40-4310 Rubber Damping Washer
- 1 34-40-4320 Seal-Cover
- 1 34-40-4350 O-Ring
- 1 34-40-0045 Cap Seal
- 1 34-40-0046 O-Ring
- 1 34-40-4470 O-Ring
- 1 42-96-0130 Bearing Cup
- 1 43-44-0970 Gasket
- 1 45-06-0680 Felt Seal
- 1 49-08-5265 7 Oz. Tube "S2" Grease

▲ SEE BACK PAGE OF THIS BULLETIN FOR ADDITIONAL LUBRICATION AND SERVICE NOTES

FIG.	PART NO.	DESCRIPTION OF PART	NO. REQ.
1	02-02-0120	1/8" Steel Ball	(12)
3	31-86-0100	Spacer	(1)
5	02-04-0911	Ball Bearing	(1)
6	02-04-1510	Ball Bearing	(1)
8	02-04-2000	Ball Bearing	(1)
9	02-50-2470	Needle Bearing	(3)
10	02-50-4020	Needle Bearing	(1)
11	02-50-9000	Needle Bearing	(1)
12	02-50-9985	Needle Bearing	(1)
14	05-81-0830	M6 x 1.0 x 70 Pan Hd. Screw T-27	(4)
18	06-65-1660	Dowel Pin	(1)
22	06-82-8842	8-32 x 3/8" Pan Hd. Slit. Taptite T-20	(1)
23	06-95-6280	M4 x 0.7 x 14 Pan Hd. Slit. Taptite T-20	(4)
28	34-60-2580	External Retaining Ring	(1)
35	34-80-5100	Internal Retaining Ring	(1)
38	40-50-8870	Compression Spring	(1)
43	30-89-0010	Bearing Retainer	(1)
44	28-14-2297	Crankcase	(1)
45	28-20-1325	Crankcase Cover	(1)
46	28-50-8680	Intermediate Housing	(1)
48	28-12-0110	Nose Flange	(1)
49	31-12-0270	Cap-Cover	(1)
57	32-05-2250	Bevel Gear	(1)
58	34-40-0045	Cap Seal	(1)
60	34-40-0046	O-Ring	(1)
61	34-40-1375	O-Ring	(1)
63	34-40-4310	Rubber Damping Washer	(1)
64	34-40-4320	Seal-Cover	(1)
65	42-76-0710	Chuck Collar	(1)
66	34-40-4350	O-Ring	(1)
67	34-40-4470	O-Ring	(1)
68	34-60-0700	Retaining Ring	(1)
69	34-80-5090	Retaining Ring-Beveled	(1)
70	36-14-0790	Clutch Shaft	(1)
71	36-14-0770	Hollow Clutch Shaft	(1)
72	14-09-0140	Crankshaft Assembly	(1)
★ 73	38-50-6145	Spindle	(1)
74	42-76-0715	Collar	(1)
75	40-50-8575	Compression Spring	(1)
76	43-34-0765	Spring Flange	(1)
78	40-50-8590	Belleville Spring	(4)
81	42-98-0300	Barrel	(1)
83	43-34-0740	Spring Flange	(1)
84	43-44-0970	Gasket	(1)
91	43-96-0220	Key	(2)
94	44-60-1710	Wrist Pin	(1)
95	44-62-0220	Piston	(1)
96	44-66-6030	Splined Clutch Plate	(1)
97	44-66-6045	Fixed Clutch Plate	(1)
98	44-82-0225	Ram	(1)
99	44-90-4400	Shift Ring	(1)
100	44-94-0395	Connecting Rod Assembly	(1)
102	44-86-0610	Key Retaining Ring	(1)
103	44-90-0005	Seal Retaining Ring	(1)
104	45-56-2620	Striker	(1)
105	06-82-8872	DG50 x 16mm Torx Pan Head Screw	(4)
106	45-06-0555	Dust Seal	(1)
107	45-88-8520	Thrust Washer	(2)
108	45-88-8530	Barrel Thrust Washer	(1)
109	45-88-8535	Striker Cushion Washer	(1)
111	45-06-0670	Oil Seal	(1)
112	45-06-0680	Felt Seal	(1)
113	45-88-8730	Wave Washer	(1)
116	42-16-0125	Side Handle Band	(1)
117	14-34-0516	Side Handle Assembly	(1)
118	14-34-0551	Depth Rod Mount Assembly	(1)
119	44-94-0165	Depth Gauge Rod	(1)
120	44-86-0620	Band Retainer	(1)
121	31-44-2000	Side Handle Housing	(1)

NOTE: Check the clutch torque. Clutch must slip at 35 to 45 ft.lbs. at the spindle, checked clockwise as viewed from the front of the tool.

▲ SEE BACK PAGE OF THIS BULLETIN FOR ADDITIONAL LUBRICATION AND SERVICE NOTES

LUBRICATION NOTES: (TYPE "S2" GREASE, NO. 49-08-5265)

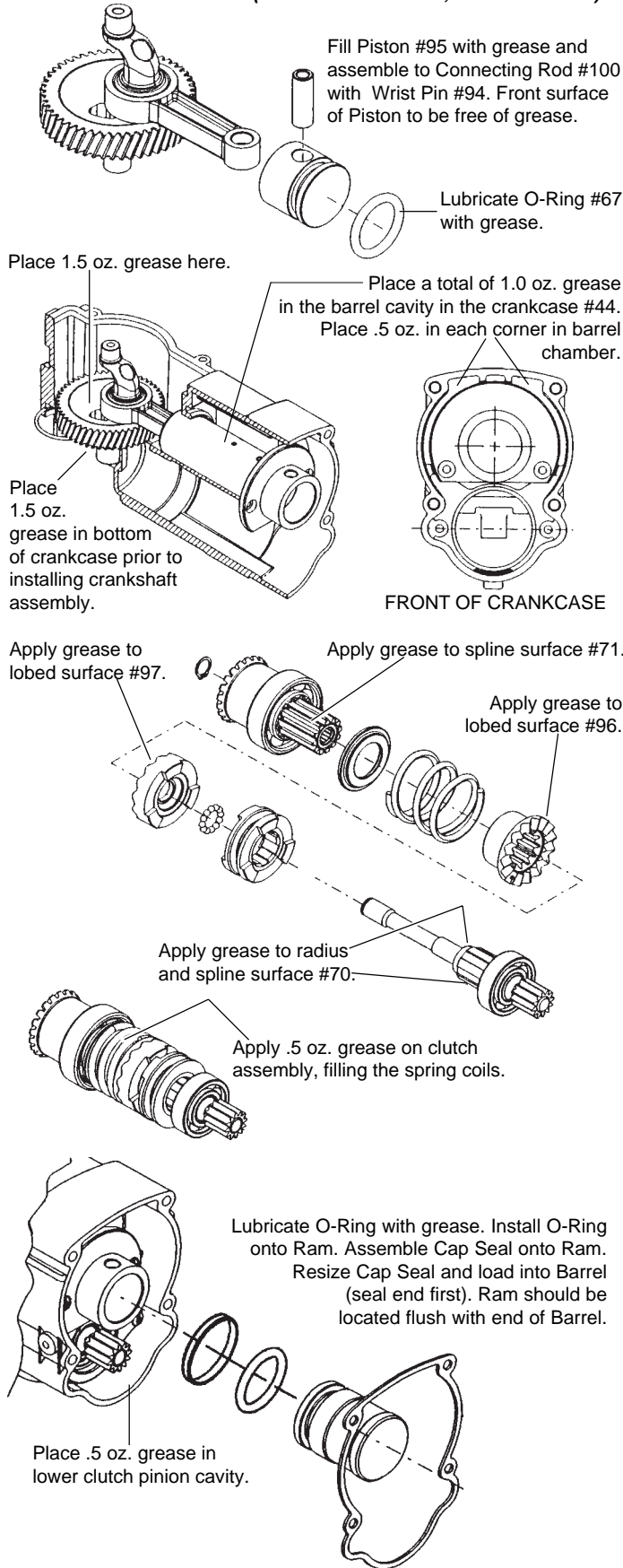

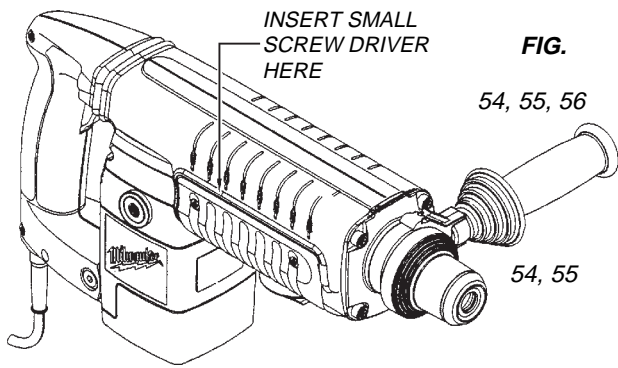

FIG.

▲ NOTES

54, 55, 56

TO REMOVE BELLY SHROUD #56 FROM TOOL, INSERT SMALL SCREW DRIVER INTO GROOVE BETWEEN BELLY AND SIDE SHROUDS #54 AND #55, ABOUT 1/3 OF THE WAY FROM THE MOTOR END, AS SHOWN. PRY OUT AND DOWN ON BOTH SIDES OF THE TOOL.

54, 55

TO INSTALL THE SIDE SHROUDS #54 AND #55, THE TOP HINGE OF THE SHROUDS MUST BE COMPLETELY INTERLOCKED, THEN THE BACK SIDE ROTATED CLOSED AROUND THE TOOL.

73

LUBRICATE ALL BORES IN SPINDLE #73 WITH A MEDIUM COATING OF GREASE.

63, 108, 109

LUBRICATE RUBBER DAMPING WASHER #63, BARREL THRUST WASHER #108 AND STRIKER CUSHION WASHER #109 WITH A MEDIUM COATING OF GREASE BEFORE ASSEMBLY.

10, 100

PRESS NEEDLE BEARING #10 IN ROD #100 SO THAT THE SAME AMOUNT STICKS OUT ON BOTH SIDES OF THE ROD, AS SHOWN.

9, 71

PRESS (2) NEEDLE BEARINGS #9 INTO HOLLOW CLUTCH SHAFT #71, FLUSH WITH THE ENDS OF THE SHAFT.

11, 12, 46

PRESS NEEDLE BEARING #11 FLUSH TO THE INSIDE SURFACE OF THE INTERMEDIATE HOUSING #46, AGAINST THE SNAP RING. PRESS NEEDLE BEARING #12 FLUSH TO THE OUTSIDE MACHINED SURFACE OF THE INTERMEDIATE HOUSING.

9, 44

PRESS NEEDLE BEARING #9 INTO CRANKCASE #44, FLUSH WITH TOP OF BORE, AS SHOWN.

81

LIGHTLY GREASE INSIDE OF BARREL #81 BEFORE ASSEMBLY.

14, 19, 20, 23

FASTENERS #14, #19, #20 AND #23 ARE TO BE RE-ASSEMBLED USING BLUE LOCTITE.

60, 61, 62, 66, 67

LUBRICATE O-RINGS #60, #61, #62, #66 AND #67 WITH GREASE.

69

INSTALL BEVEL SNAP RING #69 WITH BEVEL SIDE UP.

4, 50, 80

PLACE BEARING CUP #80 ON SMALL ARMATURE BEARING #4 BEFORE INSTALLING MOTOR COVER #50.

41

BRUSH SPRINGS #41 ARE TO BE WOUND 1/2 TURN TO ENGAGE BRUSHES.

4

RUBBER SEAL SIDE OF BALL BEARING #4 TO FACE FAN.

95, 98

FACES OF PISTON #95 AND RAM #98 ARE TO BE FREE OF GREASE.

105

WHEN REASSEMBLING BARREL AND CLUTCH SCREWS INTO EXISTING CRANKCASE, MAKE SURE SCREW IS STARTED IN EXISTING THREAD. DO NOT CREATE TWO SETS OF THREADS IN ONE HOLE.

