



SERVICE PARTS LIST

BULLETIN NO.
54-24-0171

SPECIFY CATALOG NO. AND SERIAL NO. WHEN ORDERING PARTS		REVISED BULLETIN	DATE
1/2" REV. MAGNUM HAMMER-DRILL		54-24-0170	Dec.'90
CATALOG NO. 5374-1	STARTING SERIAL NO. 715-10500	WIRING INSTRUCTION	
		58-01-0074	

00 0

EXAMPLE:
Component Parts
(Small #) Are Included
When Ordering The
Assembly (Large #).

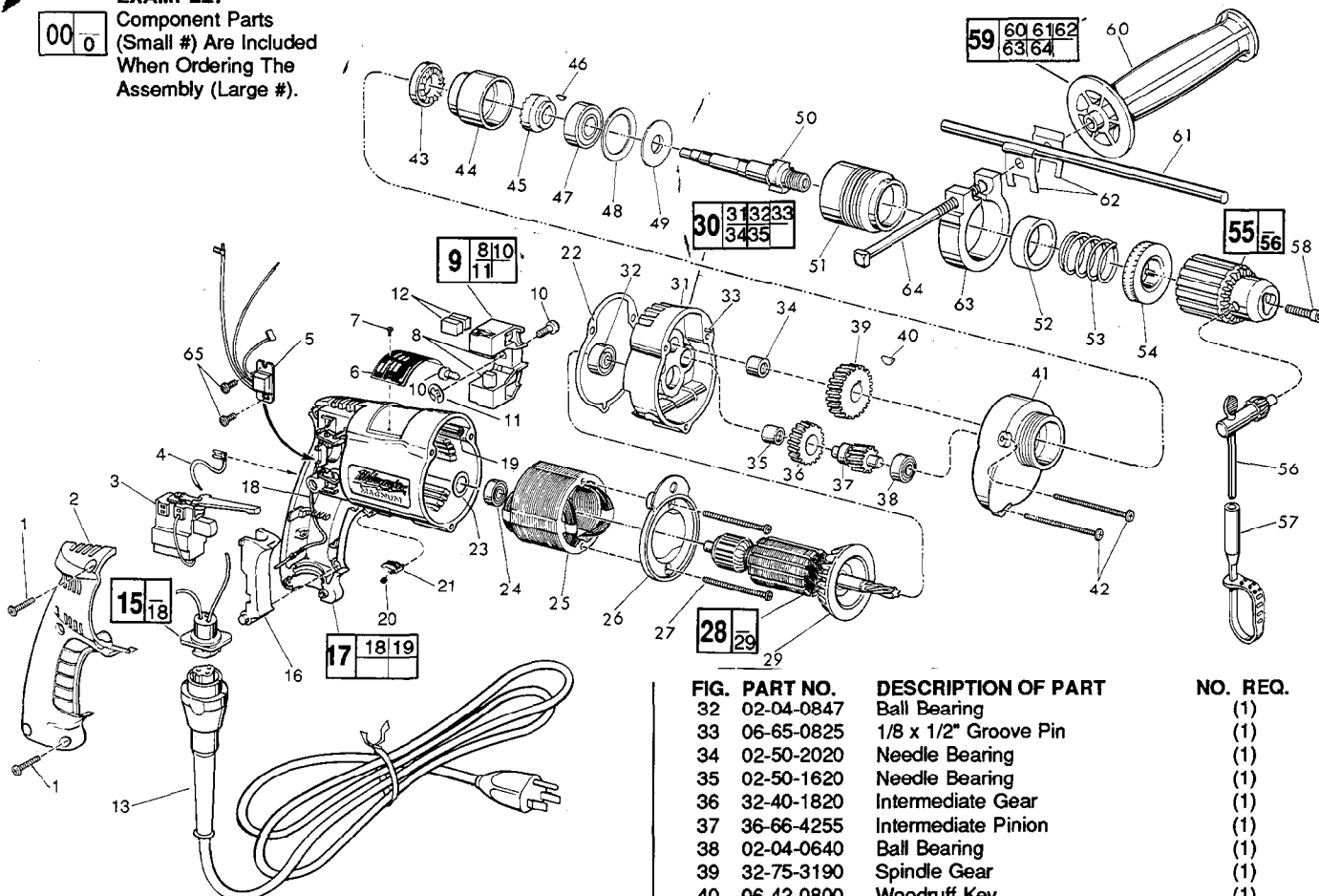

FIG.	PART NO.	DESCRIPTION OF PART	NO. REQ.
1	06-95-0185	7-18 x 11/16" Plastite Screw	(5)
2	31-15-0101	Handle Cover	(1)
★3	23-66-1665	Trigger Speed Control Reversing Switch	(1)
4	23-94-9635	2-1/4" Lead Assembly	(1)
★5	14-20-0245	Remote Electronic Assembly	(1)
6	12-99-0225	Nameplate Blank	(1)
7	06-85-0200	Nameplate Screw	(2)
8	22-16-0300	Carbon Brush	(2)
9	22-22-0355	Brush Holder Assembly	(1)
10	31-75-0011	Brush Holder Screw	(2)
11	34-60-0500	1/4" External Retaining Ring	(1)
12	22-16-0300	Carbon Brush (Spares)	(2)
13	48-76-4008	8 Foot Quik-Lok Cord Set	(1)
15	22-56-0302	Pin Housing Assembly	(1)
16	45-72-0080	Trigger	(1)
★17	14-38-0356	Motor Housing Assembly	(1)
18	23-94-9686	Ground Wire Assembly	(1)
19	44-60-0570	Grounding Pin	(1)
20	40-50-0085	Lock Button Spring	(1)
21	42-42-0150	Lock Button	(1)
22	43-44-0576	Gasket	(1)
23	45-88-7800	Gasket Washer	(1)
24	02-04-0645	Ball Bearing	(1)
25	18-10-0045	120 Volt Field	(1)
26	31-05-0065	Baffle	(1)
27	06-95-0140	7 x 1-7/8" Pan Hd. Screw	(2)
28	16-10-0500	120 Volt Armature	(1)
29	22-84-0650	Fan Assembly	(1)
30	14-13-0356	Diaphragm Assembly	(1)
31	28-28-1577	Diaphragm	(1)

FIG.	PART NO.	DESCRIPTION OF PART	NO. REQ.
32	02-04-0847	Ball Bearing	(1)
33	06-65-0825	1/8 x 1/2" Groove Pin	(1)
34	02-50-2020	Needle Bearing	(1)
35	02-50-1620	Needle Bearing	(1)
36	32-40-1820	Intermediate Gear	(1)
37	36-66-4255	Intermediate Pinion	(1)
38	02-04-0640	Ball Bearing	(1)
39	32-75-3190	Spindle Gear	(1)
40	06-42-0800	Woodruff Key	(1)
41	28-14-1795	Gear Case	(1)
42	06-95-0150	7-18 x 2-3/16" Lg. Pan Hd. Screw	(3)
43	44-84-0165	Fixed Ratchet	(1)
44	42-52-0250	Bearing Housing	(1)
45	44-84-0160	Rotating Ratchet	(1)
46	06-42-1200	Woodruff Key	(1)
47	02-04-1536	Ball Bearing	(1)
48	45-88-7350	Bearing Retainer Washer	(1)
49	45-88-7365	Spring Support Washer	(1)
50	38-50-5575	Spindle	(1)
51	45-22-0405	Sleeve (Left Hand Thread)	(1)
52	45-88-7375	Felt Washer	(1)
53	40-50-4950	Spring	(1)
54	42-76-0200	Locking Collar	(1)
★55	48-66-1365	1/2" Reversing Chuck	(1)
56	48-66-3280	Chuck Key	(1)
57	48-66-4040	Key Holder	(1)
58	06-75-3150	1/4-20 x 1" Socket Hd. Screw L.H. Thread	(1)
59	14-34-0250	Side Handle Assembly	(1)
60	43-62-0865	Side Handle	(1)
61	44-94-0161	Depth Rod	(1)
62	42-68-0390	Depth Gauge Clamp	(2)
63	28-82-0150	Handle Ring	(1)
★64	42-32-0161	5/16-18 x 3-1/2" Square Hd. Bolt	(1)
★65	06-82-7212	4-20x1/4" Pan Hd. Plastite Torx	(2)
	10-98-5986	Warning Label	(1)

FIG. LUBRICATION
41 1-1/2 Oz. Type "E" Grease, No. 49-08-4121

MILWAUKEE ELECTRIC TOOL CORPORATION
13135 W. LISBON RD., BROOKFIELD, WI 53005