



SERVICE PARTS LIST

BULLETIN NO.
54-24-5500

SPECIFY CATALOG NO. AND SERIAL NO. WHEN ORDERING PARTS		REVISED BULLETIN	DATE
1/2" (13mm) HAMMER-DRILL			Oct. 2012
CATALOG NO.	5374-20	STARTING SERIAL NO.	E62A
		WIRING INSTRUCTION See Page Two	

EXAMPLE:
Component Parts (Small #)
Are Included When Ordering
The Assembly (Large #).

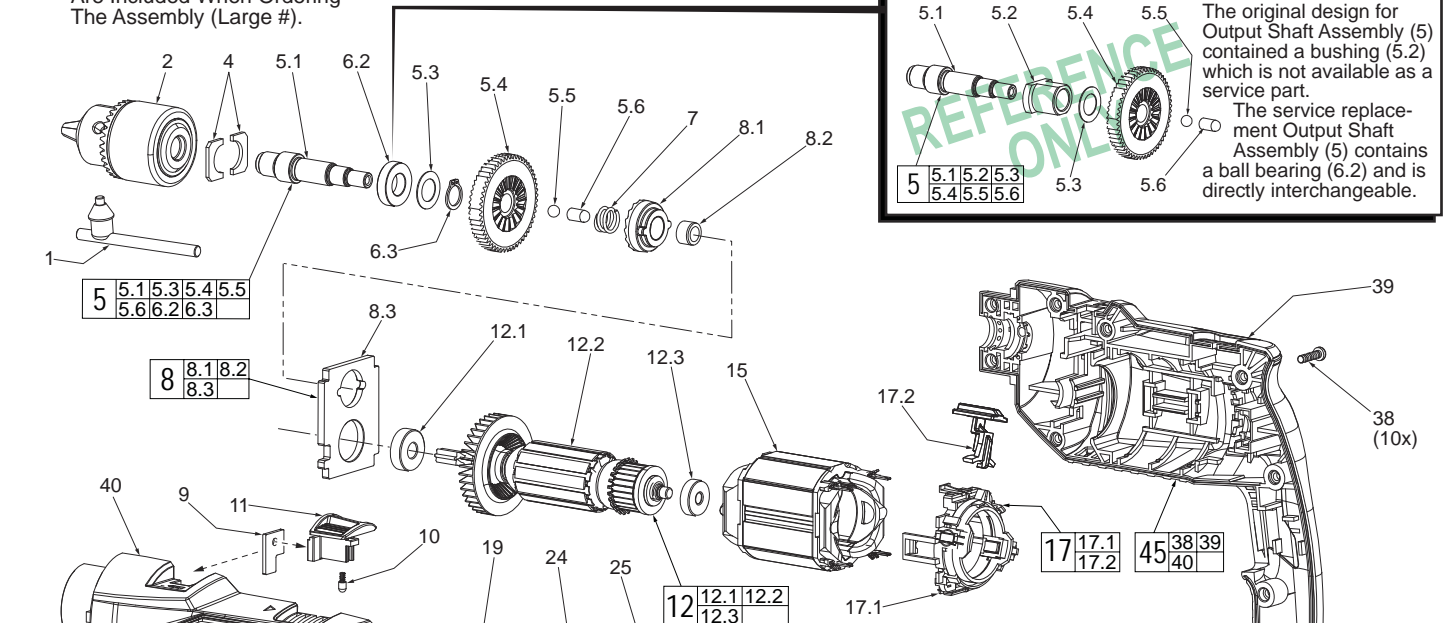

FIG.	PART NO.	DESCRIPTION OF PART	NO. REQ.
1	42-66-5364	Chuck Key	(1)
2	42-66-5365	1/2" (13mm) Keyed Chuck	(1)
4	43-44-5365	Felt Seal	(2)
5	14-29-5365	Output Shaft Assembly	(1)
5.1	-----	Output Shaft	(1)
5.3	-----	Washer	(1)
5.4	-----	Ratchet Gear	(1)
5.5	02-02-5380	Steel Ball	(1)
5.6	44-60-5381	Pin	(1)
6.2	-----	Ball Bearing	(1)
6.3	-----	External Retaining Ring	(1)
7	40-50-5365	Compression Spring	(1)
8	28-14-5365	Base Plate/Ratchet Assembly	(1)
8.1	-----	Fixed Ratchet	(1)
8.2	-----	Needle Bearing	(1)
8.3	-----	Base Plate	(1)
9	43-96-5365	Impact Plate	(1)
10	44-60-5380	Cap Assembly	(1)
11	31-05-5365	Hammer/Drill Selection Lever	(1)
12	16-07-5366	Armature Assembly	(1)
12.1	02-04-5381	Ball Bearing	(1)
12.2	-----	Armature	(1)
12.3	02-04-5382	Ball Bearing	(1)
15	18-07-5368	Service Field	(1)
17	22-22-5365	110-120V Tension Ring/Brush Assembly	(1)
17.1	-----	Tension Ring with Brushes	(1)
17.2	31-44-5365	Forward/Reverse Lever	(1)
19	23-66-5367	Variable Speed Switch	(1)
22	44-76-5365	Cord Protector	(1)
24	23-94-5364	Leadwire Assembly-White	(1)
25	23-94-5365	Leadwire Assembly-Black	(1)
26	22-64-5362	120V Power Cord	(1)
38	05-88-1200	M4 x 16 Pan Hd. Plastite T-20 Screw	(10)
39	-----	Right Housing (Cover)	(1)
40	-----	Left Housing (Support)	(1)
43	14-34-5364	Side Handle Assembly	(1)
43.1	31-05-5366	Side Handle	(1)
43.2	05-88-5365	M8 x 1.25 Hex Bolt	(1)
43.3	05-88-5366	M8 Square Nut	(1)
43.4	31-05-5368	Carrier	(1)
43.5	31-05-5369	Lock Ring	(1)
44	31-05-5367	Depth Gauge	(1)
45	14-34-5365	Housing Assembly	(1)

LUBRICATION NOTES:
Type 'E' Grease, No. 49-08-4122, 1lb. can

Place 5g ±.5g grease in Left Housing

Place 8g ±.5g grease in Right Housing

Prior to reinstalling, clean the gear assembly with a clean, dry cloth. Lightly coat all parts highlighted here with 'E' grease. Apply a greater amount of grease to all internal and external gear teeth.

When servicing, remove 90-95% of the existing grease prior to installing Type 'E' grease. Original grease may be similar in color but not compatible with 'E'.