



SERVICE PARTS LIST

BULLETIN NO.
55-24-0243

SPECIFY CATALOG NO. AND SERIAL NO. WHEN ORDERING PARTS		REVISED BULLETIN	DATE
3/8" PISTOL HAMMER DRILL			May '91
CATALOG NO. 5392-3	STARTING SERIAL NO. 665-1001	WIRING INSTRUCTION 58-03-0980	

EXAMPLE:



Component Parts (Small #) Are Included
When Ordering The Assembly (Large #).

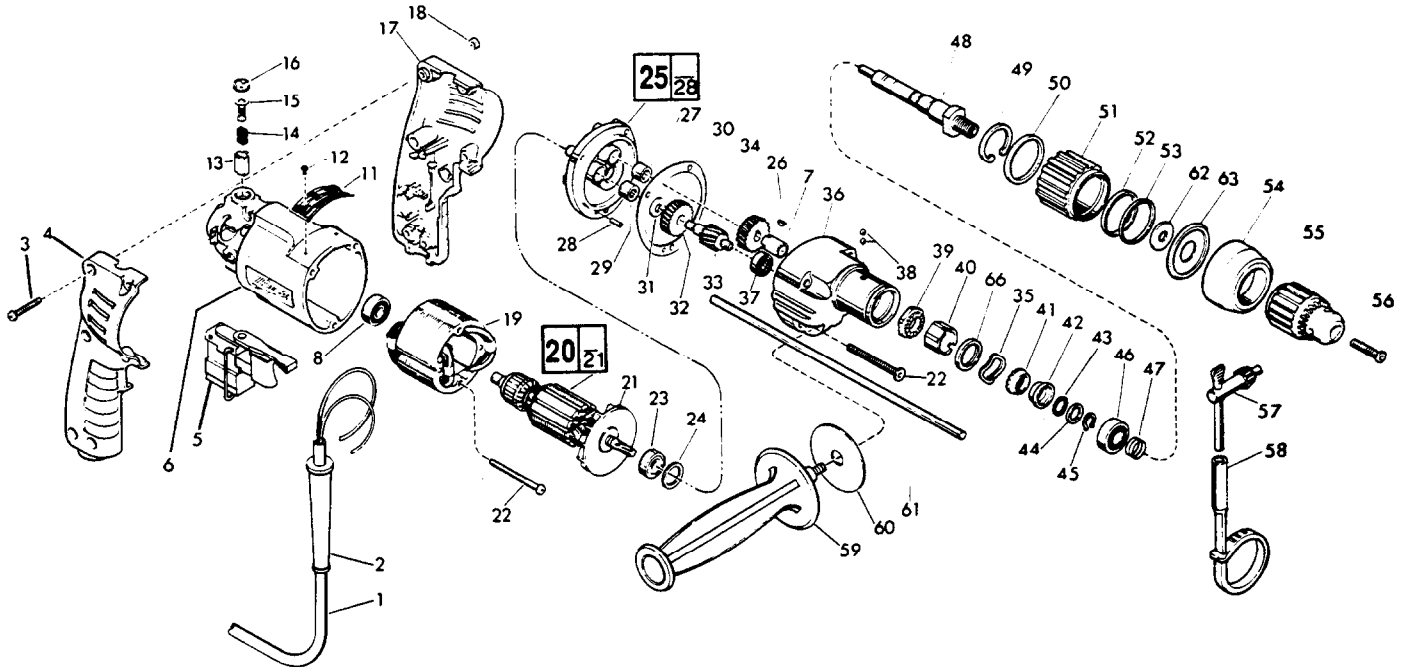

FIG.	PART NO.	DESCRIPTION OF PART	NO. REQ.
1	22-64-4480	Cord Set	(1)
2	44-76-0210	Cord Protector	(1)
3	06-82-2361	8-32 x 15/16" Slit. Plast. T-20	(6)
4	31-44-1130	Right Handle Half	(1)
5	23-66-1505	Speed Control Switch	(1)
6	31-50-0346	Motor Housing	(1)
7	45-36-1260	Gear Spacer	(1)
8	02-04-0645	Ball Bearing	(1)
11	12-99-0570	Nameplate Blank	(1)
12	06-85-0200	Nameplate Screw	(2)
13	22-20-0530	Brush Tube	(2)
14	22-16-0375	Carbon Brush	(2)
15	23-52-0210	Brush Spring Assembly	(2)
16	23-44-0120	Brush Retaining Screw	(2)
17	31-44-1140	Left Handle Half	(1)
18	06-55-0835	8-32 Hex Nut	(6)
19	18-14-0130	220 Volt Field	(1)
20	16-14-0370	220 Volt Armature	(1)
21	22-84-0830	Fan Assembly	(1)
22	06-82-7393	7-18x2" Pan Hd. Slit. Plast. T-20	(5)
23	02-04-0848	Ball Bearing	(1)
24	45-88-0355	Fiber Washer	(1)
25	28-28-1820	Diaphragm Assembly	(1)
26	06-42-0400	Woodruff Key	(1)
27	02-50-1611	Needle Bearing	(1)
28	06-65-0800	Groove Pin	(1)
29	02-50-1640	Needle Bearing	(1)
30	43-44-0900	Gasket	(1)
31	45-88-7721	Thrust Washer	(1)
32	32-40-1940	Intermediate Gear	(1)
33	36-66-4360	Intermediate Pinion Shaft	(1)
34	32-75-3175	Spindle Gear	(1)
35	45-88-0940	Overlap Wave Washer	(1)
36	28-14-2100	Gear Case	(1)
37	02-04-0640	Ball Bearing	(1)
38	02-02-0180	3/16" Steel Ball	(6)

FIG.	PART NO.	DESCRIPTION OF PART	NO. REQ.
39	44-84-0240	Fixed Ratchet	(1)
40	45-36-1225	Bearing Spacer	(1)
41	44-84-0235	Rotating Ratchet	(1)
42	45-36-1215	Shift Spacer	(1)
43	02-02-0120	1/8" Steel Ball	(15)
44	45-88-0935	Thrust Washer	(1)
45	34-60-0920	Retaining Ring	(1)
46	02-08-0510	Ball Bearing	(1)
47	40-50-0220	Compression Spring	(1)
48	38-50-5515	Spindle	(1)
49	34-80-2020	Internal Retaining Ring	(1)
50	34-40-4040	O-Ring	(1)
51	31-58-0055	Locking Collar	(1)
52	34-40-1500	O-Ring	(1)
53	34-60-2125	Retaining Ring	(1)
54	49-62-0090	Hammer Dust Shield	(1)
55	48-66-0795	3/8" Chuck	(1)
56	45-04-0750	Chuck Screw	(1)
57	48-66-3240	Chuck Key	(1)
58	48-66-4040	Key Holder	(1)
59	43-62-0905	Side Handle	(1)
60	45-88-7930	Washer	(1)
61	44-94-0161	Depth Rod	(1)
62	45-88-1040	Washer	(1)
63	44-86-0510	Retainer	(1)
66	45-36-1255	Flanged Spacer	(1)

FIG. NOTES

- 23 Press flush to casting surface. Seal towards armature.
- 56 Apply type 242 blue loctite and torque to 40-45 in./lbs.

FIG. LUBRICATION

- 36 1-1/2 oz. type "K" grease, No. 49-08-4161.
- 39,41 1/2 tsp. type "K" grease, No. 49-08-4161.
- 42,43 1/4 tsp. type "K" grease, No. 49-08-4161.
- 50,52 Coat with type "K" grease, No. 49-08-4161.

MILWAUKEE ELECTRIC TOOL CORPORATION
13135 W. LISBON RD., BROOKFIELD, WI 53005