



# SERVICE PARTS LIST

BUL. 54-38-2014

## 7" DISC SANDER

REVISED BUL 649-5 DATE Feb. '68

Catalog No. 6020

Starting Serial No. 49-6925

WIRING INSTR.

Both Model and Serial No. must be furnished to obtain correct parts.

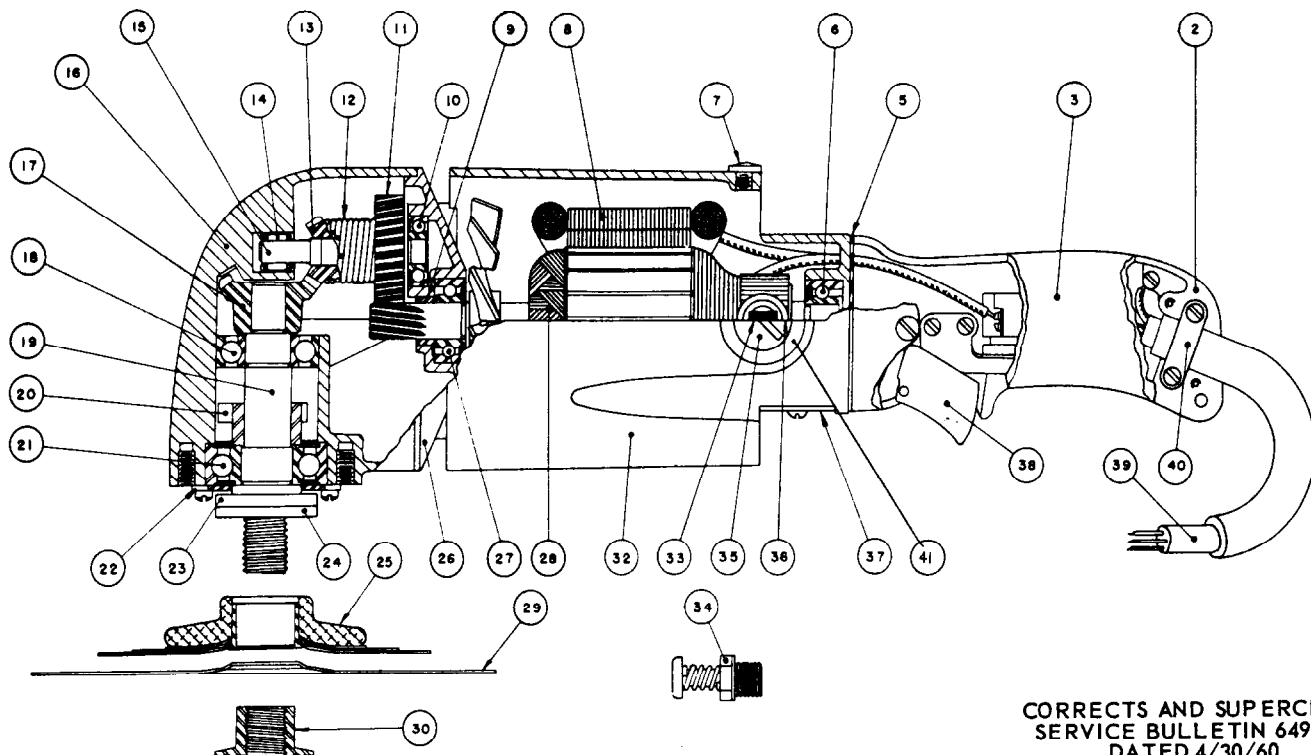

CORRECTS AND SUPERCEDES SERVICE BULLETIN 649-5 DATED 4/30/60

### ILLUSTRATED PARTS

FIG.	PART NO.	DESCRIPTION OF PART	FIG.	PART NO.	DESCRIPTION OF PART
2	28-44-1041	Handle (Switch Mounting Side)	22	45-88-0220	Ball Brg. Retaining Washer
3	28-44-9081	Handle (Switch Cover Side)	23	45-88-0141	Hub Steel Washer
5	43-86-0050	Handle Insulator	24	45-88-0160	Hub Rubber Washer
6	02-04-1070	Ball Brg. (Comm. End)	25	48-80-0750	5" Flat Disc Hub Assembly
7	06-77-1400	Drive Screw Tool Rest Button	26	28-28-0381	Diaphragm
8	18-82-1180	Field Assembly	27	02-04-1340	Ball Brg. (Pinion End)
9	45-28-0080	Grease Slinger	28	16-82-1710	Armature Assembly
10	02-04-0920	Ball Bearing	29	48-80-0900	7" Flat Backing Disc
11	32-40-1481	Intermediate Gear	30	44-40-0120	Disc Nut (5/8"-11 Thread)
12	40-50-3200	Spindle Drive Spring	32	28-50-4562	Motor Housing
13	32-50-1241	Miter Gear (Sold only with 32-50-1261 as set)	33	22-18-0260	Carbon Brush Assembly
14	02-50-2130	Needle Bearing	34	44-20-0060	Spindle Lock Assembly
15	36-66-3301	Intermediate Shaft	35	23-44-0065	Brush Retaining Cap
16	28-14-0601	Gear Case	36	22-22-0130	Brush Holder Assembly (per set 2)
17	32-50-1261	Refer to Item 13	37	44-66-0100	Commutator Cover Plate
18	02-04-1710	Ball Bearing (Upper)	38	23-66-0250	Switch Assembly
19	38-50-1751	Spindle (5/8"-11 Thread)	39	22-64-0090	Cord Set
20	42-74-0061	Spindle Lock Cog	40	28-17-0200	Cord Clamp Strap
21	02-04-2060	Ball Bearing (Lower)	41	22-24-0100	Brush Holder Bushing (steel) (2)

### MISCELLANEOUS PARTS NOT SHOWN

PART NO.	DESCRIPTION OF PART	PART NO.	DESCRIPTION OF PART
28-79-0241	Tool Rest	06-81-8650	6-32x1/4" Rd. Hd. Comm. Cover Plate Scs. (Sem) (2)
48-03-0010	Adapter Plug	06-81-3700	8-32x7/8" Oval Hd. Handle Cover Screws (2)
12-98-3500	Name Plate	06-81-6100	8-32x7/16" Fil. Hd. Cord Clamp Strap Scs. (Sem) (2)
43-62-0141	Side Handle Assembly	06-81-5400	8-32x5/16" Binder Hd. Switch Mounting Scs. (2)
06-81-6950	10-24x1/2" Fil. Hd. Sem Tool Rest Sc. (2)	06-81-8950	8-32x2-1/4" Rd. Hd. Field Screws (Sem) (2)
06-83-2650	1/4"-20x3/8" Hd. less Brush Holder Set Scs. (2)	06-81-8625	6-32x1/4" Rd. Hd. Ground Wire Sc. (Brass) (Sem)
06-81-7250	10-24x1-1/2" Fil. Hd. Gear Case Scs. (Sem) (4)	06-81-8200	4-36x3/16 Rd. Hd. Name Plate Scs. (Sem) (2)
06-81-7550	12-24x3/4" Fil. Hd. Switch Handle Scs. (Sem) (4)	06-81-6050	8-32x5/16" Fil. Hd. Ret. Washer Scs. (Sem) (6)
06-81-3750	8-32x1" Oval Hd. Handle Cover Screw	23-86-0130	Insulating Washer

Numbers in brackets indicate number required.