



SERVICE PARTS LIST

BULLETIN NO.
54-38-0390

SPECIFY CATALOG NO. AND SERIAL NO. WHEN ORDERING PARTS		REVISED BULLETIN	DATE
5" Random Orbit Sander			Jan. 2014
CATALOG NO. 6021-21	STARTING SERIAL NUMBER B19A	WIRING INSTRUCTION SEE REVERSE	

EXAMPLE:
00 $\frac{0}{0}$ Component Parts (Small #)
Are Included When Ordering
The Assembly (Large #).

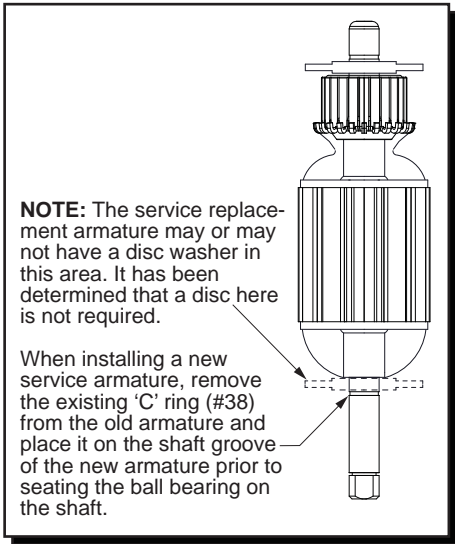
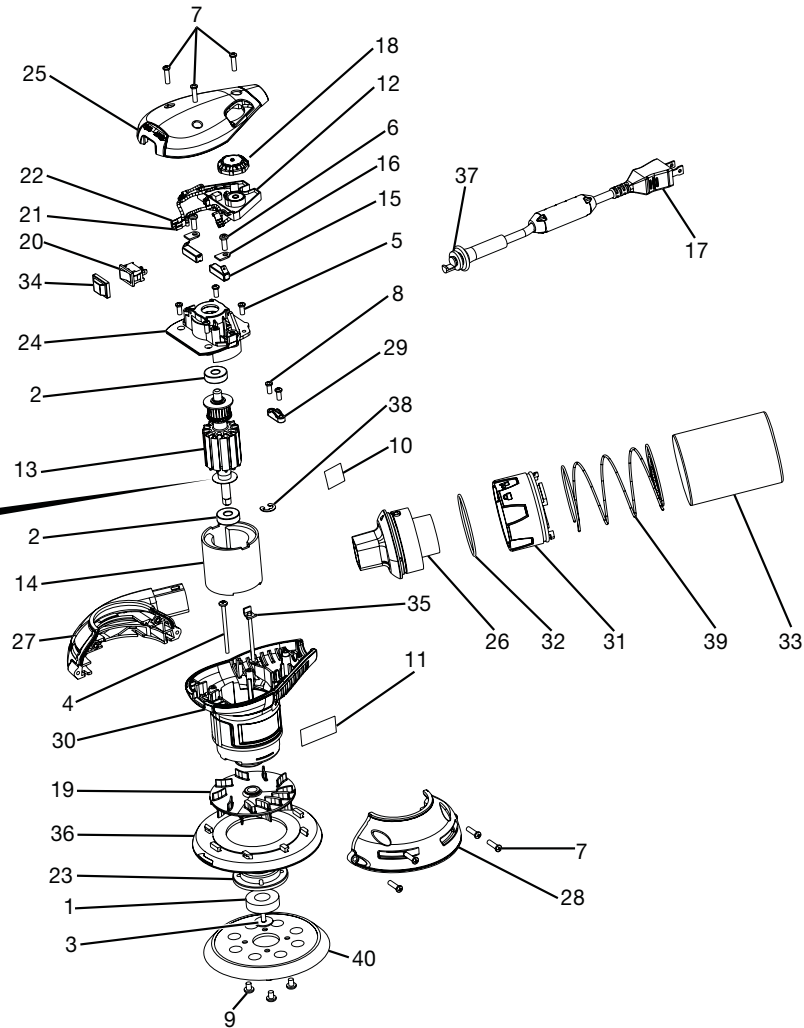

FIG.	PART NO.	DESCRIPTION OF PART	NO. REQ.	FIG.	PART NO.	DESCRIPTION OF PART	NO. REQ.
1	02-04-5160	Bearing	1	26	31-15-1525	Dust Chute (See Note)	1
2	02-04-5165	Bearing	2	27	31-15-1530	Lower Housing Dust Chute Cover (See Note)	1
3	06-81-0120	Screw w/Washer, Torx, T25, 10-32 UNF-2A x 1/2"	1	28	31-15-1535	Lower Housing Cover	1
4	06-81-0130	Screw, Torx, T20	2	29	31-17-0530	Cord Clamp	1
5	06-81-0135	Screw, Torx, T20	4	30	31-50-2120	Motor Housing	1
6	06-81-0140	Screw, Torx, T20	2	31	31-58-0690	Dust Bag Locking Ring	1
7	06-81-0145	Screw, Torx, T15	7	32	34-40-1870	Dust Chute O-Ring	1
8	06-81-0150	Screw, Torx, T15	2	33	42-16-0570	Dust Bag	1
9	06-81-0155	Screw, Torx, T25	4	34	42-38-0405	Switch Boot	1
10	10-98-6045	Multilingual Warning Label	1	35	42-70-1005	Field Retaining Clip	2
11	12-20-6045	Name Plate	1	36	44-52-0965	Brake Pad	1
12	14-20-0185	PCB Board	1	37	44-76-0315	Strain Relief	1
13	16-10-0631	Armature	1	38	44-86-1380	Retaining Ring	1
14	18-10-0141	Field	1	39	40-50-1110	Compression Spring	1
15	22-18-1170	Carbon Brush Assembly w/Shunt Wire	2	40	51-36-7090	Hook-and-Loop Sanding Disc Assembly	1
16	22-38-0180	Brush Clamp	2	41	22-56-0150	Wire Connector	2
17	22-64-1210	Cord	1		51-36-7095	PSA Sanding Disc	1
18	22-75-0090	Speed Control Knob	1		42-55-6022	Carrying Case (Not Shown)	1
19	22-84-0980	Fan	1				
20	23-66-1661	Switch	1				
21	23-94-1265	Black Switch Wire Harness	1				
22	23-94-1270	Brown Switch Wire Harness	1				
23	28-12-0365	Bearing Cap	1				
24	31-12-0405	Plastic Bearing Cap	1				
25	31-12-0410	Cap with Overmold	1				

NOTE: Items 26 and 27 fit together with a one-time snap. When replacing one piece, you must replace the other.

WIRING INSTRUCTIONS

NOTE:

As an aid to reassembly, take note of the wire routings and position of the wires in the wire guides and wire guides traps prior to dismantling the tool.

Watch for pinched wires when placing the handle cover back over the housing assembly.

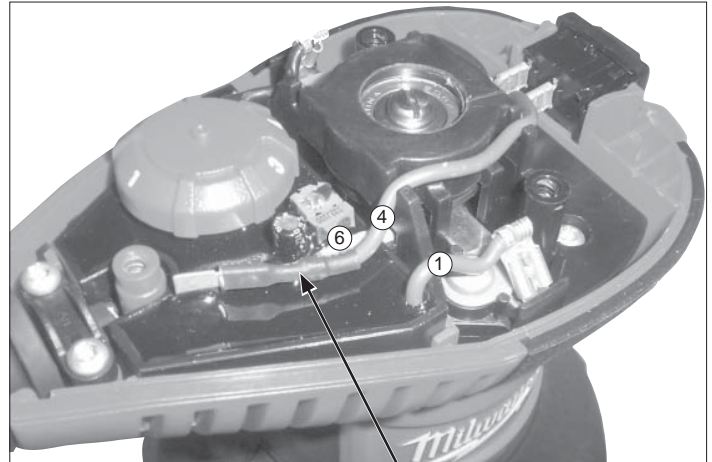
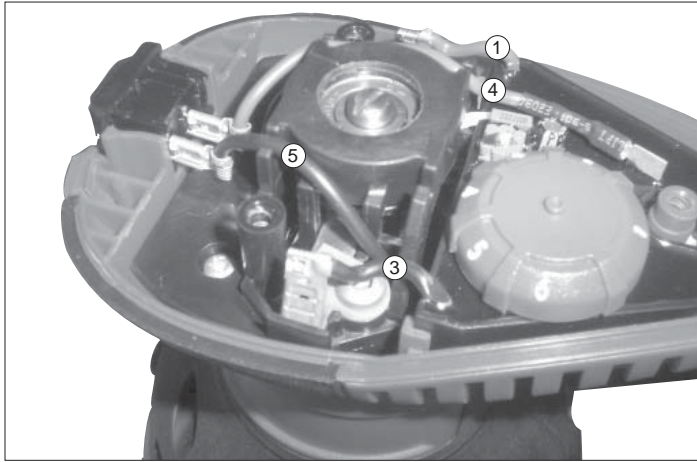

Add .8" of Shrink Tube (ø 5 mm).

Use Wire Connectors 22-56-0150 to connect wire 2 to wire 5 and connect wire 6 to wire 7.

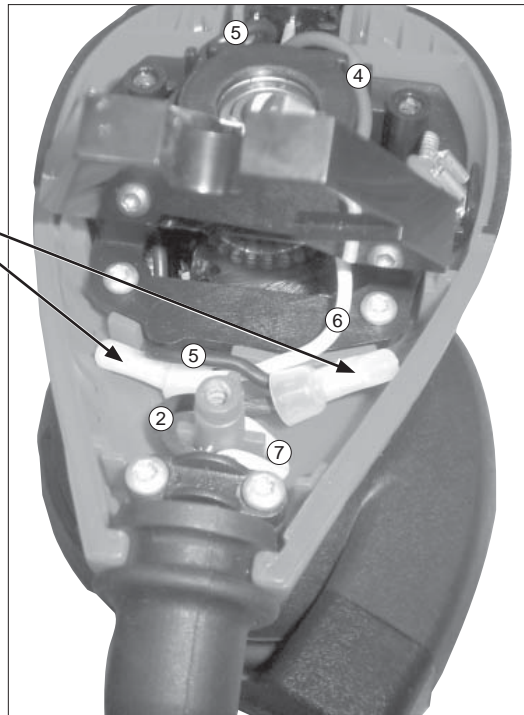

NOTE:
All leads must be held to ± 1/16".
All lead lengths are before stripping.

WIRING SPECIFICATIONS			
Wire No.	Wire Color	Length	Terminals, Connectors and 1 or 2 End Wire Preparation
1	Red	-----	Component of PCB
2	Black	-----	Component of Cord
3	Black	-----	Component of PCB
4	Brown	-----	Switch Wire Harness
5	Black	-----	Switch Wire Harness
6	White	-----	Component of PCB
7	White	-----	Component of Cord

BULK LEAD WIRE - BULLETIN 58-01-0003

TERMINAL DESCRIPTION		
Code	Part No.	Qty.