



SERVICE PARTS LIST

BUL. 54-38-3104

9" DISC SANDER

REVISED BUL 648-5 DATE Feb. '68

Catalog No. 6060

Starting Serial No. **48-4800**

WIRING INSTR.

Both Model and Serial No. must be furnished to obtain correct parts.

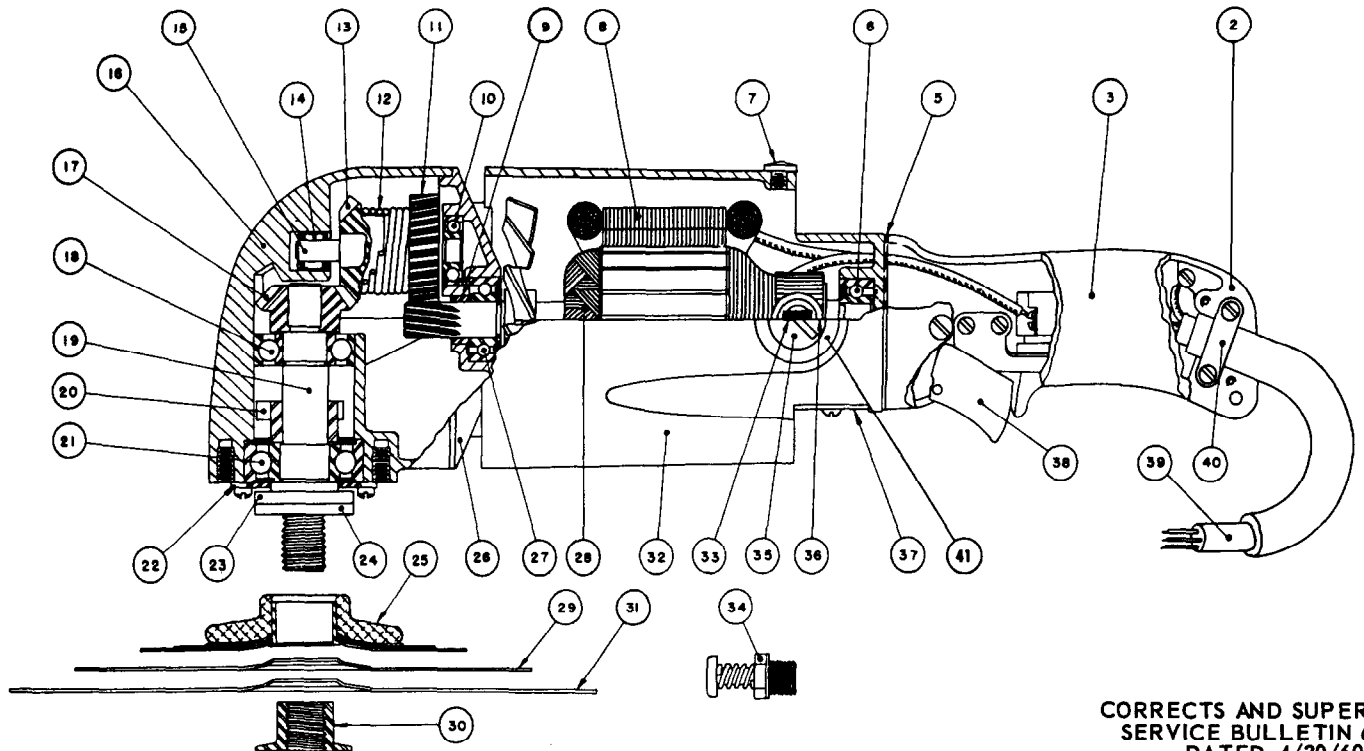

**CORRECTS AND SUPERCEDES
SERVICE BULLETIN 648-5
DATED 4/30/60**

ILLUSTRATED PARTS

FIG.	PART NO.	DESCRIPTION OF PART
2	28-44-1041	Handle (Switch Mounting Side)
3	28-44-9081	Handle (Switch Cover Side)
5	43-86-0050	Handle Insulator
6	02-04-1070	Ball Bearing (Comm. End)
7	06-77-1400	Drive Screw Tool Rest Button
8	18-82-1180	Field Assembly
9	45-28-0080	Grease Slinger
10	02-04-0920	Ball Bearing
11	32-40-1481	Intermediate Gear
12	40-50-3200	Spindle Drive Spring
13	32-50-1241	Miter Gear (Sold only with 32-50-1261 as set)
14	02-50-2130	Needle Bearing
15	36-66-3301	Intermediate Shaft
16	28-14-0601	Gear Case
17	32-50-1261	Refer to Item 13
18	02-04-1710	Ball Bearing (Upper)
19	38-50-1751	Spindle (5/8"-11 Thread)
20	42-74-0061	Spindle Lock Cog
21	02-04-2060	Ball Bearing (Lower)
22	45-88-0220	Ball Brg. Retaining Washer

FIG.	PART NO.	DESCRIPTION OF PART
23	45-88-0141	Hub Steel Washer
24	45-88-0160	Hub Rubber Washer
25	48-80-0750	5" Flat Disc Hub Assembly
26	28-28-0381	Diaphragm
27	02-04-1340	Ball Brg. (Pinion End)
28	16-82-1710	Armature Assembly
29	48-80-0900	7" Flat Backing Disc
30	44-40-0120	Disc Nut (5/8"-11 Thread)
31	48-80-1100	9" Flat Backing Disc
32	28-50-4562	Motor Housing
33	22-18-0260	Carbon Brush Assembly
34	44-20-0060	Spindle Lock Assembly
35	23-44-0065	Brush Retaining Cap
36	22-22-0130	Brush Holder Assembly (per set 2)
37	44-66-0100	Commutator Cover Plate
38	23-66-0250	Switch Assembly
39	22-64-0090	Cord Set
40	28-17-0200	Cord Clamp Strap
41	22-24-0100	Brush Holder Bushing (Steel)

MISCELLANEOUS PARTS NOT SHOWN

PART NO.	DESCRIPTION OF PART
28-79-0241	Tool Rest
48-03-0010	Adapter Plug (3 Prong)
12-98-3500	Name Plate
43-62-0141	Side Handle Assembly
23-86-0130	Insulating Washer (2)
06-81-6950	10-24x1/2" Fil.Hd.Sem. Tool Rest Screw (2)
06-83-2650	1/4"-20x3/8" Hd'less Brush Holder Set Sc.(2)
06-81-7550	12-24x3/4" Fil.Hd.Switch Handle Sc.(Sem)(4)
06-81-7250	10-24x1-1/2" Fil.Hd.Gear Case Scs.(Sem)(4)

PART NO.	DESCRIPTION OF PART
06-81-3750	8-32x1" Oval Hd. Handle Cover Screw
06-81-8650	6-32x1/4" Rd. Hd. Comm. Cover Plate Sc. (Sem)
06-81-3700	8-32x7/8" Oval Hd. Handle Cover Screw
06-81-6100	8-32x7/16" Fil. Hd. Cord Clamp Strap Sc.(Sem)
06-81-5400	8-32x5/16" Rd. Hd. Switch Mounting Screw (Binder)
06-81-8950	8-32x2-1/4" Rd.Hd. Field Screw (Sem)
06-81-8625	6-32x1/4" Rd.Hd. Ground Screw (Brass) (Sem)
06-81-8200	4-36x3/16" Rd.Hd. Name Plate Screws (Sem)
06-81-6050	8-32x5/16" Fil.Hd.Reg. Washer Scs. (Sem)

Numbers in brackets indicate number required.