



# SERVICE PARTS LIST

BUL. 54-38-9203

## 9" DISC SANDER

Catalog No. 6060-8

Starting Serial No. 154-2781

REVISED BUL. 6154-4 DATE Feb. 68  
WIRING INSTR.

Both Model and Serial No. must be furnished to obtain correct parts.

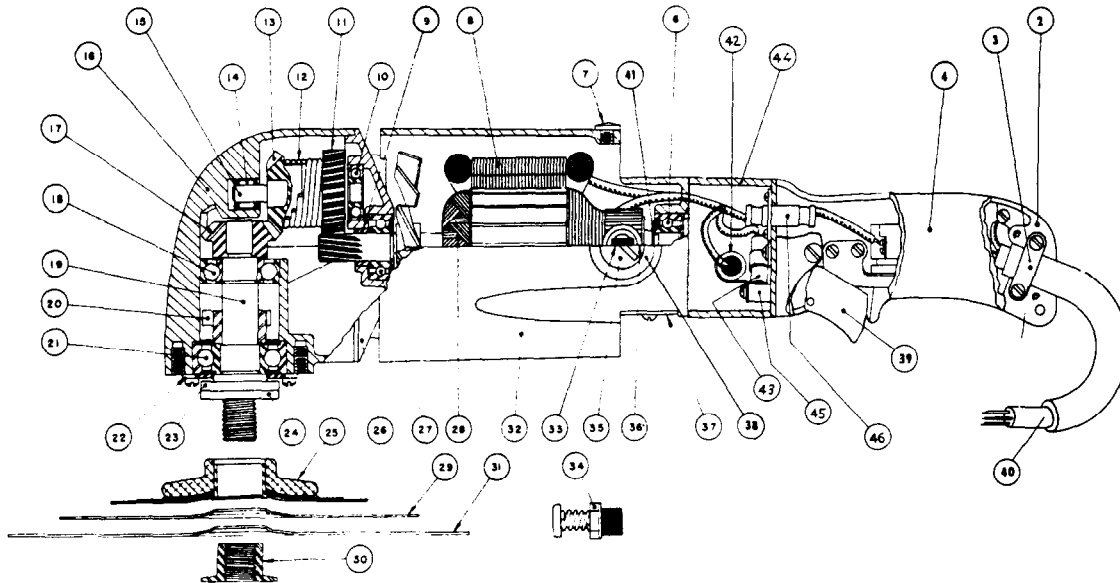

### ILLUSTRATED PARTS

FIG.	PART NO.	DESCRIPTION OF PART	FIG.	PART NO.	DESCRIPTION OF PART
2	28-44-1041	Handle (Switch Mounting Side)	26	28-28-0381	Diaphragm
3	28-17-0200	Cord Clamp Strap	27	02-04-1340	Ball Bearing (Pinion End)
4	28-44-9081	Handle (Switch Cover Side)	28	16-82-1720	Armature Assembly
6	02-04-1070	Ball Bearing (Comm. End)	29	48-80-0900	7" Flat Backing Disc
7	06-77-1400	Drive Screw Tool Rest Button	30	44-40-0120	Disc Nut (5/8-11 Thread)
8	18-82-1170	Field Assembly	31	48-80-1100	9" Flat Backing Disc
9	45-28-0080	Grease Slinger	32	28-50-4562	Motor Housing
10	02-04-0920	Ball Bearing	33	22-18-0080	Carbon Brush Assembly
11	32-40-1481	Intermediate Gear	34	44-20-0060	Spindle Lock Assembly
12	40-50-3200	Spindle Drive Spring	35	23-44-0065	Brush Retaining Cap
13	32-50-1241	Miter Gear (Sold only with 32-50-1261 as set)	36	22-22-0055	Brush Holder Assembly (per set 2)
14	02-50-2130	Needle Bearing	37	44-66-0100	Commutator Cover Plate
15	36-66-3301	Intermediate Shaft	38	22-24-0100	Brush Holder Bushing Steel
16	28-14-0601	Gear Case	39	23-66-0250	Switch Assembly
17	32-50-1261	Refer to Item 13	40	22-64-0160	Cord Set
18	02-04-1710	Ball Bearing (Upper)	41	43-06-0070	Grounding Disc
19	38-50-1751	Spindle (5/8-11 Thread)	★42	22-33-4000	.22 MFD Condenser
20	42-74-0061	Spindle Lock Cog	★43	22-33-3460	R.H. Condenser (.1 MFD)
21	02-04-2060	Ball Bearing (Lower)		22-33-3450	L.H. Condenser (.1 MFD)
22	45-88-0220	Ball Bearing Retaining Ring	★44	28-50-8123	Radio Suppression Box
23	45-88-0141	Hub Steel Washer	★45	45-36-0190	Spacer
24	45-88-0160	Hub Rubber Washer	★46	22-33-6450	.01 MFD Condenser (2)
25	48-80-0750	5" Flat Disc Hub Assembly			

### MISCELLANEOUS PARTS NOT SHOWN

PART NO.	DESCRIPTION OF PART	PART NO.	DESCRIPTION OF PART
28-79-0241	Tool Rest	06-81-3750	8-32x1 Oval Hd. Handle Cover Screw
★12-65-3900	Name Plate (Dwg. No. 4)	06-81-8650	6-32x1/4 Rd.Hd. Comm. Cover Plate Screw
43-62-0141	Side Handle Assembly	06-81-3700	8-32x7/8 Oval Hd. Handle Cover Screw
23-86-0130	Insulating Washer (2)	06-81-6150	8-32x1/2 Fil.Hd. Cord Clamp Strap Screw
06-81-6950	10-24x1/2 Fil.Hd. Tool Rest Sem (2)	06-81-5400	8-32x5/16 Binder Hd. Switch Mtg. Screw
06-83-2650	1/4-20x3/8 Hd'less Brush Holder Set Screw (4)	06-81-6750	8-32x2-1/2 Fil. Hd. Field Sem
06-81-1625	12-24x2-1/4 Fil.Hd. Switch Handle Screw (4)	06-81-8625	6-32x1/4 Rd.Hd. Ground Screw (Brass)
06-81-7250	10-24x1-1/2 Fil.Hd. Gear Case Screws (4)	06-81-8200	4-36x3/16 Rd.Hd. Name Plate Screw
12-98-5100	Warning Plate	06-81-6050	8-32x5/16 Fil.Hd. Ret. Washer Screw
06-77-0450	No. 4x1/4 Drive Pin (2)	★48-03-0010	Plug Adapter