



SERVICE PARTS LIST

BULLETIN NO.
55-38-2110

SPECIFY CATALOG NO. AND SERIAL NO. WHEN ORDERING PARTS		REVISED BULLETIN	DATE
115mm COMPACT ANGLE GRINDER with SLIDE SWITCH			Mar. 2016
CAT. NO.	6149-59A	STARTING SERIAL NUMBER	D11A
		WIRING INSTRUCTION See Reverse Side	

FIG.	PART NO.	DESCRIPTION OF PART	NO. REQ.
1	05-88-1650	M4 x 25mm Pan Hd. ST Screw T-20	(4)
2	42-62-0120	Side Handle Assembly	(1)
3	14-30-1155	Gearcase Assembly	(1)
3a	-----	Spindle Lock Button	(1)
3b	-----	Spindle Lock Spring	(1)
3c	-----	Gearcase	(1)
3d	-----	O-Ring	(1)
3e	-----	Spindle Lock Pin	(1)
3f	-----	Needle Bearing	(1)
3g	02-04-0620	Ball Bearing	(1)
4	34-40-0560	O-Ring	(1)

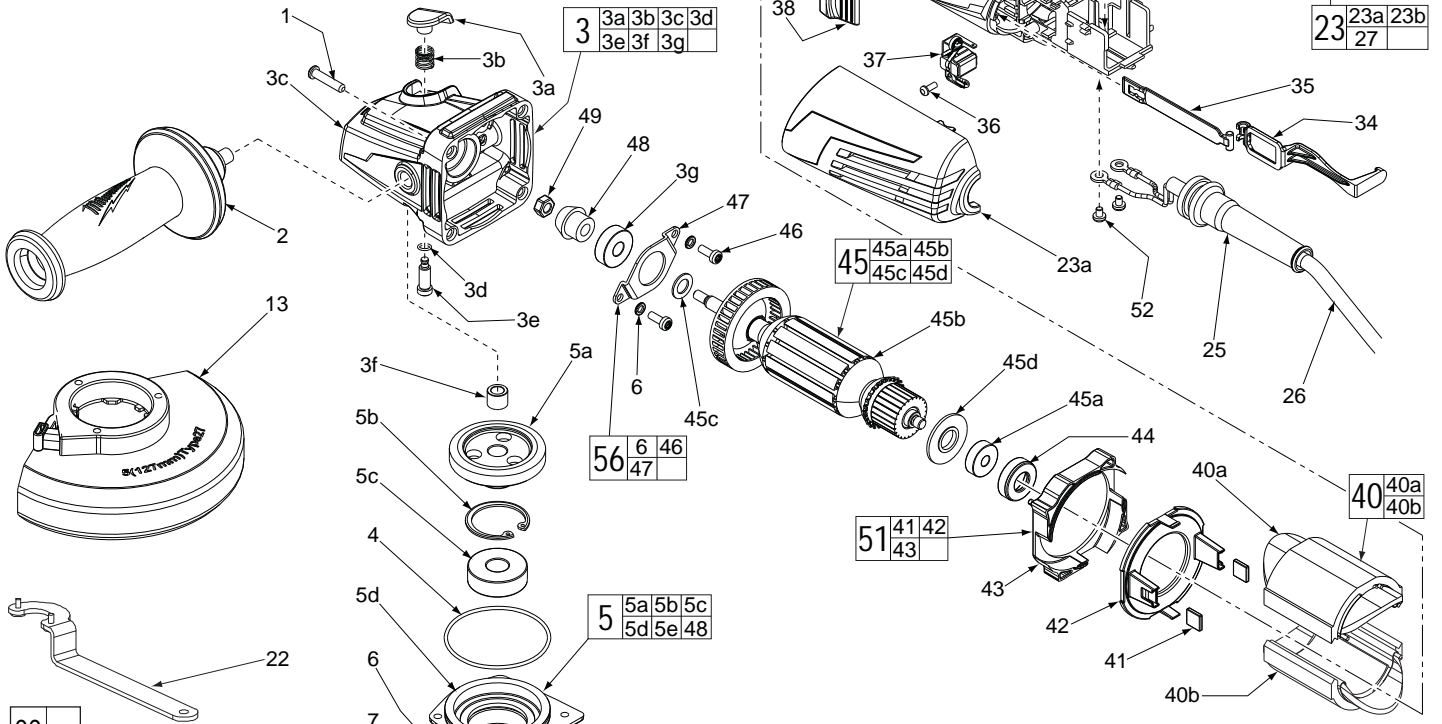

EXAMPLE:
Component Parts (Small #)
Are Included When Ordering
The Assembly (Large #).

***LUBRICATION NOTE:**
When servicing the Gears (5a & 48)
or the Gearcase (3c), 90-95% of the
old grease must be removed prior to
new grease being added.

FIG. LUBRICATION*
5a,48 Type "Y" Grease, No. 49-08-5270,
Must Be Applied To All Gear Teeth.

5	14-46-0418	M14 Spindle Hub Kit	(1)
5a	-----	Spiral Bevel Gear	(1)
5b	-----	Retaining Ring	(1)
5c	-----	Ball Bearing	(1)
5d	-----	Spindle Hub	(1)
5e	-----	M14 Spindle	(1)
6	05-90-0225	Spring Washer	(6)
7	05-88-1210	M4 x 14mm Pan Hd. Mach. Screw T-20	(4)
13	14-32-0210	4.5" Type 27 Guard Assembly (Shown)	(1)
13	43-54-0920	4.5" Type 1 Guard Assy. (Not Shown)	(1)
15	-----	O-Ring	(1)
16	-----	Wavey Spring	(1)
17	-----	Flange with Ramps	(1)
18	-----	Retaining Ring	(1)
19	43-34-0935	Inner Disc Flange	(1)
21	44-40-0035	Outer Flange Nut	(1)
22	49-96-0015	Spanner Wrench	(1)
23	14-34-6110	Rear Handle Set	(1)
23a	-----	Left Handle Halve	(1)

FIG.	PART NO.	DESCRIPTION OF PART	NO. REQ.
23b	-----	Right Handle Halve	(1)
25	44-76-0095	Cord Protector	(1)
26	22-64-3435	Power Cord	(1)
27	05-88-1300	M4 x 28mm Pan Hd. ST Screw T-20	(4)
33	23-66-2665	On-Off Switch	(1)
34	31-84-0080	Slide Pole - Back	(1)
35	31-84-0085	Slide Pole - Front	(1)
36	05-88-0030	M3 x 8.5mm Pan Hd. ST Screw T-10	(2)
37	22-18-2245	Carbon Brush Assembly (Set of 2)	(1)
38	31-89-0245	Slide Switch Button	(1)
39	31-50-0675	Motor Housing	(1)
40	18-04-2215	Field Assembly	(1)
40a	-----	Field Halve	(1)
40b	-----	Field Halve	(1)
41	42-28-0085	Rubber Block	(2)
42	-----	Baffle Foot	(1)
43	-----	Baffle	(1)
44	42-96-0016	Rubber Bearing Cap	(1)
45	16-04-0055	Armature Assembly	(1)
45a	02-04-2110	Ball Bearing	(1)
45b	-----	Armature	(1)
45c	45-88-0406	Washer	(1)
45d	31-86-0090	Plastic Disc	(1)
46	05-88-1280	M4 x 10mm Pan Hd. Mach. Screw T-20	(2)
47	44-86-0155	Bearing Retainer	(1)
48	-----	Pinion	(1)
49	05-55-0620	M5 Hex Nut	(1)
50	14-46-6105	Flange with Ramps Assembly	(1)
51	42-14-0520	Baffle Assembly	(1)
52	05-78-0305	M3.5 x 7mm Pan Hd. Phil. Switch Scr.	(2)
56	44-86-0145	Bearing Retaining Plate Assembly	(1)

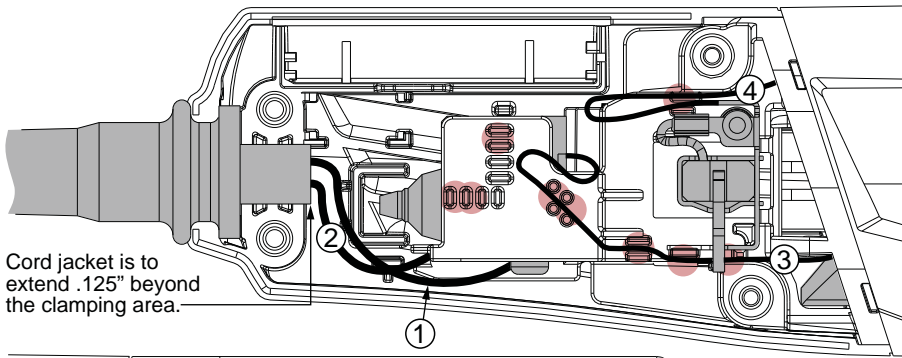

Cord jacket is to extend .125" beyond the clamping area.

AS AN AID TO REASSEMBLY, TAKE NOTICE OF WIRE ROUTING AND POSITION IN WIRE GUIDES AND TRAPS WHILE DISMANTLING TOOL.

BE CAREFUL AND AVOID PINCHING WIRES BETWEEN HANDLE HALVES WHEN ASSEMBLING.

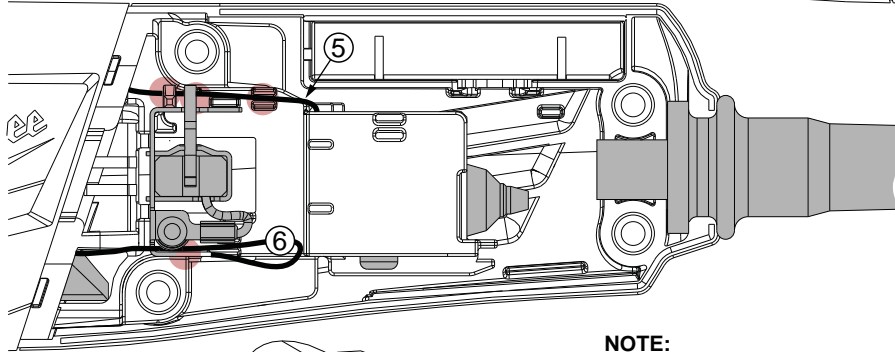

● = WIRE TRAPS or GUIDES

NOTE:
Install the switch down into the motor housing prior to installing cord wires 1 and 2 from under motor housing.

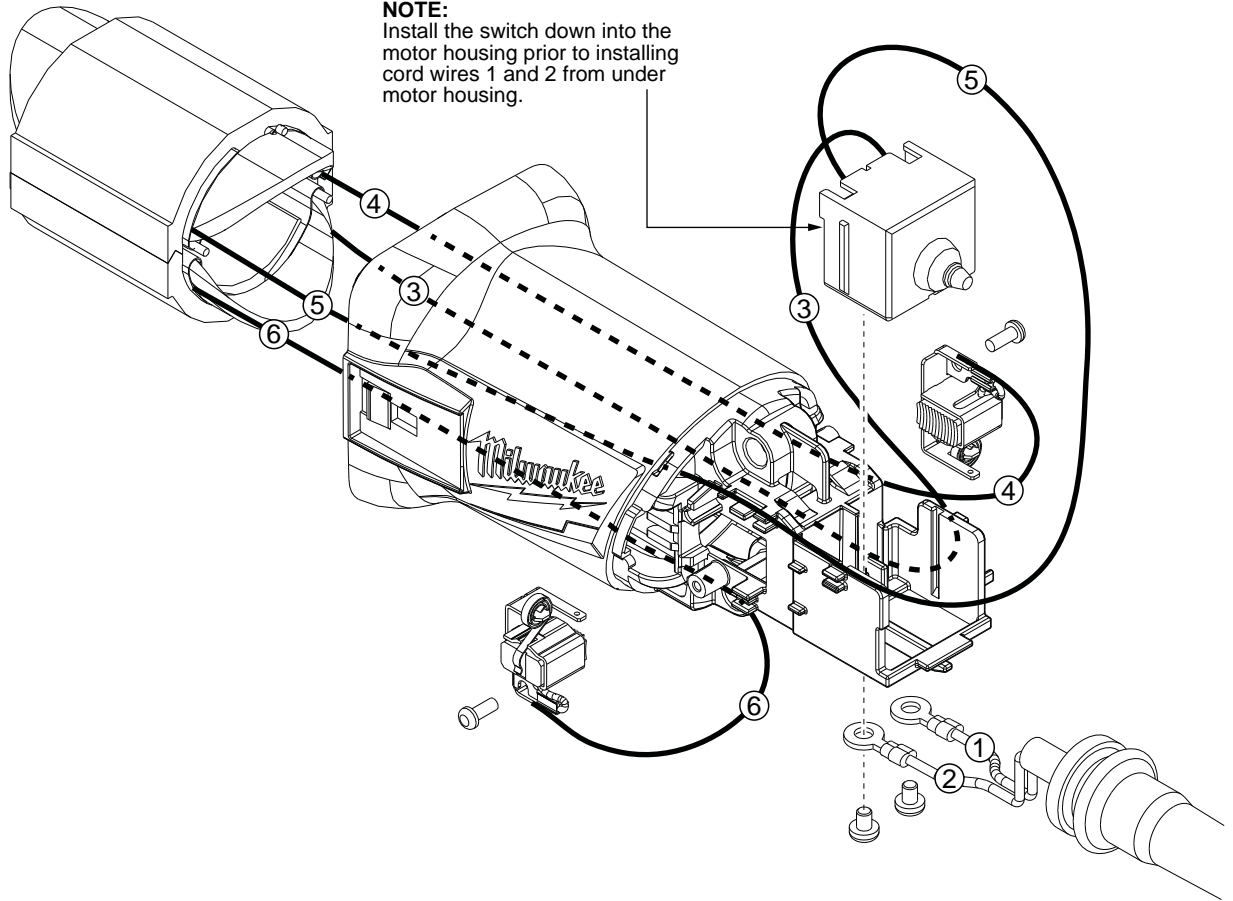

NOTE:
All leads must be held to $\pm 1/16"$.
All lead lengths are before stripping.

WIRING SPECIFICATIONS

Wire No.	Wire Color	Origin or Part No.	Gauge	Length	Terminals, Connectors and End Wire Preparation
1	Blue	22-64-3435	--	--	Component of Cord Set. Connect to Switch.
2	Brown	22-64-3435	--	--	Component of Cord Set. Connect to Switch.
3	Black	18-04-2215	--	--	Component of Field. Connect to Switch.
4	Black	18-04-2215	--	--	Component of Field. Connect to Right Brush Assy.
5	Black	18-04-2215	--	--	Component of Field. Connect to Switch.
6	Black	18-04-2215	--	--	Component of Field. Connect to Left Brush Assy.

BULK LEAD WIRE - BULLETIN 58-01-0003

TERMINAL DESCRIPTION

Code	Part No.	Qty.

CONNECTOR DESCRIPTION

--	--	--