



SERVICE PARTS LIST

BULLETIN NO.
55-38-1325

SPECIFY CATALOG NO. AND SERIAL NO. WHEN ORDERING PARTS		REVISED BULLETIN	DATE
125mm SUPER MAG GRINDER			Feb. 2000
CATALOG NO. 6155-50	STARTING SERIAL NUMBER	949A	
WIRING INSTRUCTION			

EXAMPLE:

00	0
----	---

 Component Parts (Small #) Are Included When Ordering The Assembly (Large #).

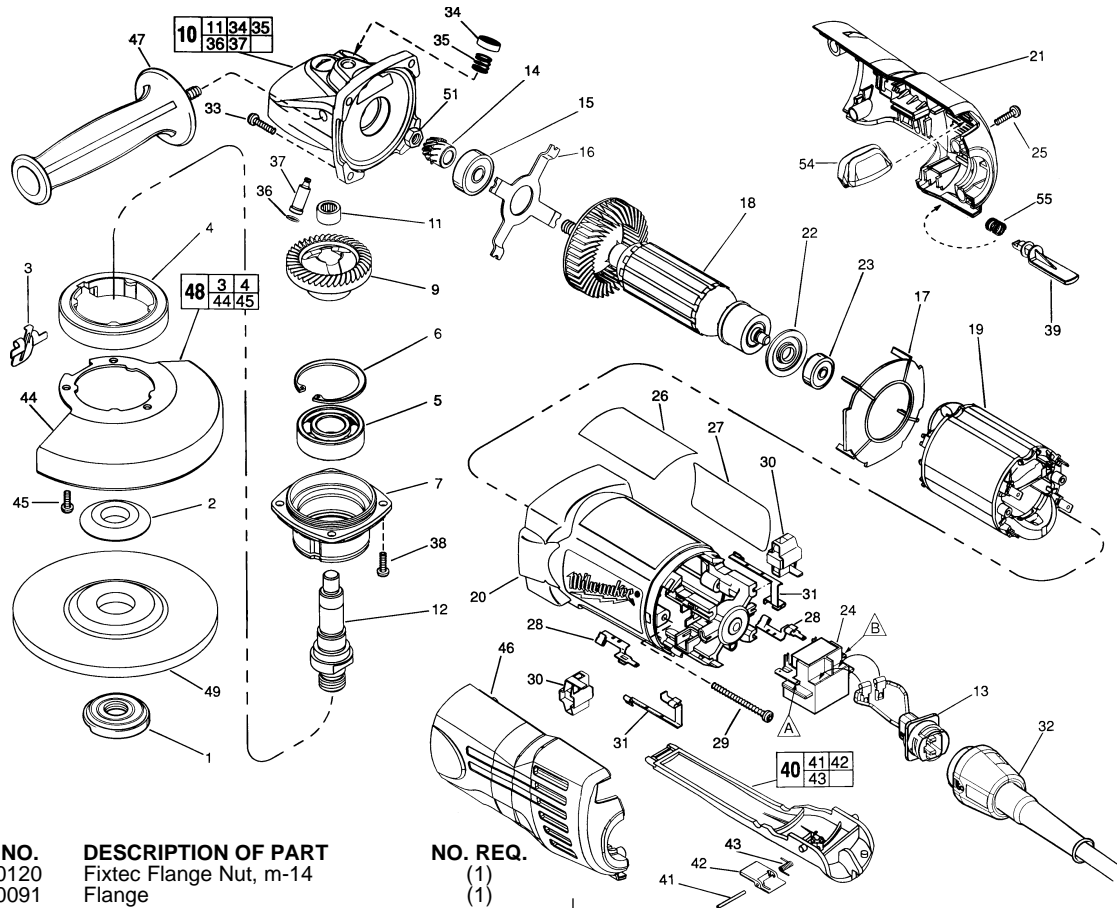

FIG.	PART NO.	DESCRIPTION OF PART	NO. REQ.
1	05-59-0120	Fixtec Flange Nut, m-14	(1)
2	49-05-0091	Flange	(1)
3	44-20-0325	Lock Lever	(1)
4	45-36-1551	Spacer	(1)
5	02-04-1745	Ball Bearing	(1)
6	34-80-2960	Retaining Ring - Internal	(1)
7	28-52-0222	Spindle Hub	(1)
9	32-05-1310	P.M. Gear	(1)
10	25-14-2350	Gear Case Assembly	(1)
11	02-50-2423	Needle Bearing	(1)
12	38-50-6065	Spindle, m-14	(1)
13	22-56-0691	Quik-Lok Blade Housing	(1)
14	32-60-1310	Pinion Gear	(1)
15	02-04-2076	Ball Bearing	(1)
16	44-66-5345	Bearing Retainer Plate	(1)
17	42-14-0400	Baffle	(1)
18	16-04-2005	230 Volt Armature	(1)
19	18-04-2005	230 Volt Field	(1)
20	31-50-1100	Motor Housing	(1)
21	31-44-0660	Right Cover	(1)
22	23-16-0100	Commutator Insulator	(1)
23	02-04-2080	Ball Bearing	(1)
24	23-66-2407	Switch	(1)
25	06-82-7271	6-19 x 7/8" Pan Hd. Plastite T-15	(4)
26	-----	Nameplate	(1)
27	10-15-6149	Logo Label	(1)
28	23-74-1206	Brush Terminal	(2)
29	06-82-7421	6-19 x 3-1/4" Pan Hd. Slit. Plast. T-15	(2)
30	22-20-0910	Brush Holder Assy. (Incl. Carbon Brush)	(2)
31	23-74-1201	Switch Terminal	(2)
32	48-76-5012	Quik-Lok Cord Set	(1)
★ 32	22-64-0684	Quik-Lok Cord Set (Australia)	(1)
33	06-82-7326	8-16 x 1" Pan Hd. Slit. Plast. T-20	(4)
34	31-12-0205	Cap	(1)
35	40-50-8650	Compression Spring	(1)
36	34-40-4300	O-Ring	(1)
37	44-60-0845	Lock Pin	(1)
38	06-82-5316	8-32 x 1/2" Pan Hd. Slit. Tapt. T-20	(4)
39	42-42-0030	Lock On Button	(1)

FIG.	PART NO.	DESCRIPTION OF PART	NO. REQ.
40	31-92-0320	Paddle Assembly	(1)
41	06-65-1915	Pin	(1)
42	42-42-0390	Lock-Off Button	(1)
43	40-50-8750	Torsion Spring	(1)
44	28-41-1025	Hood	(1)
45	06-82-7251	8-16 x 3/8" Pan Hd. Slit. Plast. T-20	(3)
46	31-44-0665	Left Cover	(1)
47	49-15-0310	Side Handle	(1)
48	49-12-0366	Guard Assembly	(1)
49	-----	125mm Disc - Select From Catalog	(1)
51	06-55-3850	10-32 Hex Nut	(1)
54	31-53-0150	Plug	(1)
55	40-50-0921	Lock On Spring	(1)
	49-96-7205	Spanner Wrench	(1)

FIG. LUBRICATION:
 9,14 Type "O" Grease, No. 49-08-4200, Must Be Applied To All Gear Teeth.
 10 18-21 Grams Type "O" Grease, No. 49-08-4200.

FIG. NOTES:
 7 Position The Spindle Hub With The Side That Has The Word "Back" Orientated Toward The Rear Of The Tool.
 11 Press 2.3mm Below Casting Surface With Lettering Readable After Assembly.
 32 Blade Housing Leads Are Interchangeable On Switch Connections.
 51 Torque To 2.85-4.0 Nm.