



SERVICE PARTS LIST

BULLETIN NO.
54-38-1820

| | | | |
|--|-----------------------------|---|-----------|
| SPECIFY CATALOG NO. AND SERIAL NO. WHEN ORDERING PARTS | | REVISED BULLETIN | DATE |
| 6" ANGLE GRINDER with PADDLE SWITCH w/Lock-Off | | | Oct. 2009 |
| CATALOG NO. 6160-30 | STARTING SERIAL NUMBER B74A | WIRING INSTRUCTION See Reverse Side | |

| FIG. | PART NO. | DESCRIPTION OF PART | NO. REQ. |
|------|------------|----------------------------|----------|
| 1 | 05-55-0620 | M5 Hex Nut | (1) |
| 2 | 05-88-1210 | M4 x 14 Pan Hd. T-20 Screw | (4) |
| 3 | 05-88-1250 | M4 x 20 Pan Hd. T-20 Screw | (6) |
| 4 | 05-88-1280 | M4 x 10 Pan Hd. T-20 Screw | (2) |
| 5 | 05-88-1290 | M4 x 76 Pan Hd. T-20 Screw | (2) |
| 6 | 05-88-1300 | M4 x 28 T-20 Screw | (2) |
| 7 | 05-90-0225 | M4 Lock Washer | (6) |
| 9 | 10-15-1230 | Warning Label | (1) |
| 10 | 12-20-6116 | Service Nameplate | (1) |
| 11 | 40-50-1480 | Torsion Spring | (1) |

Rubber Slug (30) is to be placed in a cavity by the bearing bore in the back of Motor Housing (29).

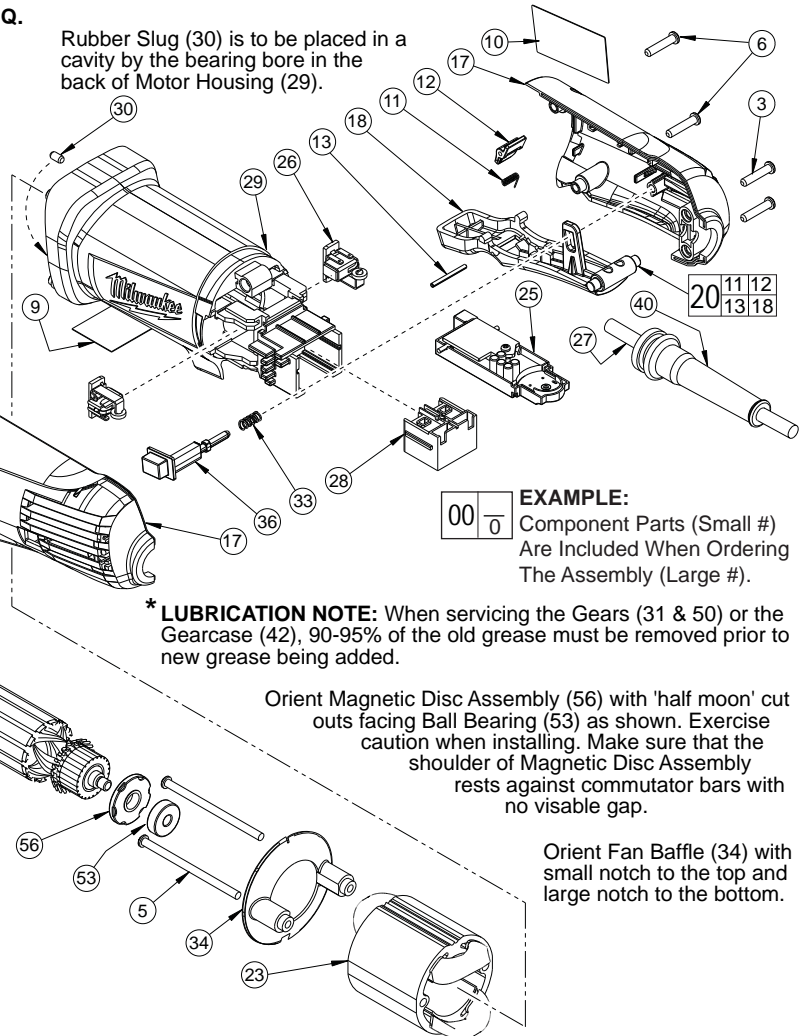

Functionally check Spindle Lock mechanism. Spindle Lock Pin (47) must return briskly when released from engagement in Gear (50).

NOTE: Torque Armature Nut (1) to 47 in/lbs, 55 kg/cm.

EXAMPLE:
00 0
Component Parts (Small #) Are Included When Ordering The Assembly (Large #).

*** LUBRICATION NOTE:** When servicing the Gears (31 & 50) or the Gearcase (42), 90-95% of the old grease must be removed prior to new grease being added.

Orient Magnetic Disc Assembly (56) with 'half moon' cut outs facing Ball Bearing (53) as shown. Exercise caution when installing. Make sure that the shoulder of Magnetic Disc Assembly rests against commutator bars with no visible gap.

Orient Fan Baffle (34) with small notch to the top and large notch to the bottom.

Orient the Needle Bearing (41) such that side with vendor I.D. is facing the Gear (50).

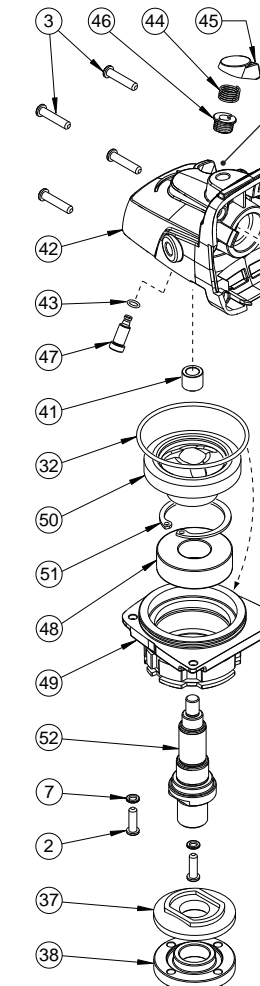
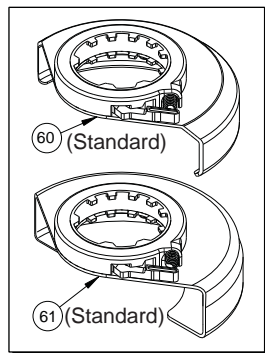

| FIG. | PART NO. | DESCRIPTION OF PART | NO. REQ. |
|------|------------|---------------------------|----------|
| 12 | 42-42-0620 | Lock-Off Button | (1) |
| 13 | 06-65-1200 | Lock-Off Pin | (1) |
| 16 | 14-29-0310 | Gearcase Assembly | (1) |
| 17 | 14-34-0725 | Rear Handle Assembly | (1) |
| 18 | 31-92-0420 | Paddle | (1) |
| 19 | 14-73-0410 | Spindle/Hub Assembly | (1) |
| 20 | 14-78-0500 | Paddle Assembly | (1) |
| 21 | 16-10-7010 | Service Armature Assembly | (1) |
| 23 | 18-07-2305 | Service Field | (1) |
| 25 | 22-09-1725 | Module Assembly | (1) |
| 26 | 22-22-1560 | Carbon Brush Assembly | (2) |
| 27 | 22-64-2020 | Cord | (1) |
| 28 | 23-66-2665 | Switch | (1) |
| 29 | 31-50-2420 | Motor Housing | (1) |
| 30 | 31-53-0240 | Rubber Slug | (1) |
| 31 | 32-60-1310 | Bevel Pinion | (1) |
| 32 | 34-40-0180 | O-Ring | (1) |
| 33 | 40-50-1625 | Lock-On Spring | (1) |
| 34 | 42-14-0490 | Fan Baffle | (1) |
| 36 | 42-42-0660 | Lock-On Shaft | (1) |
| 37 | 43-34-0036 | Inner Disk Flange | (1) |
| 38 | 44-40-0035 | Outer Flange Nut | (1) |
| 39 | 44-66-0450 | Bearing Retainer | (1) |

| FIG. | PART NO. | DESCRIPTION OF PART | NO. REQ. |
|------|------------|----------------------------------|----------|
| 40 | 44-76-0210 | Strain Relief | (1) |
| 41 | 02-50-0025 | Needle Bearing | (1) |
| 42 | | Gearcase | (1) |
| 43 | 34-40-0450 | O-Ring | (1) |
| 44 | 40-50-1330 | Compression Spring | (1) |
| 45 | 42-42-0590 | Spindle Lock Button | (1) |
| 46 | 42-42-0580 | Spindle Lock Tube | (1) |
| 47 | 42-60-1660 | Spindle Lock Pin | (1) |
| 48 | 02-04-1150 | Ball Bearing | (1) |
| 49 | 28-53-0410 | Lower Gearcase Hub | (1) |
| 50 | 32-05-1310 | Bevel Gear | (1) |
| 51 | 34-80-2275 | Retaining Ring | (1) |
| 52 | 38-50-1280 | Spindle | (1) |
| 53 | 02-04-2110 | Ball Bearing | (1) |
| 54 | 45-88-0406 | Washer | (1) |
| 55 | 02-04-0620 | Ball Bearing | (1) |
| 56 | 23-27-0110 | Magnetic Disc Assembly | (1) |
| 60 | 43-54-1080 | 6" T27 Guard Assembly (Standard) | (1) |
| 61 | 43-54-1085 | 6" T1 Guard Assembly (Standard) | (1) |
| | 42-62-0100 | Side Handle (Not Shown) | (1) |
| | 49-96-7205 | Spanner Wrench (Not Shown) | (1) |

- FIG. LUBRICATION** (*See lubrication note above):
- 31,50 Type "Y" Grease, No. 49-08-5270, Must Be Applied To All Gear Teeth.
 - 32,42 Lightly coat with grease O-Ring and bearing bore in Gearcase.
 - 42 .3 -.4 Ounces (9-12 Grams) Type "Y" Grease, No. 49-08-5270.

MILWAUKEE ELECTRIC TOOL CORPORATION
13135 W. Lisbon Road, Brookfield, WI 53005
Drwg. 3

AS AN AID TO REASSEMBLY, TAKE NOTICE OF WIRE ROUTING AND POSITION IN WIRE GUIDES AND TRAPS WHILE DISMANTLING TOOL. BE CAREFUL AND AVOID PINCHING WIRES BETWEEN HANDLE HALVES WHEN ASSEMBLING.

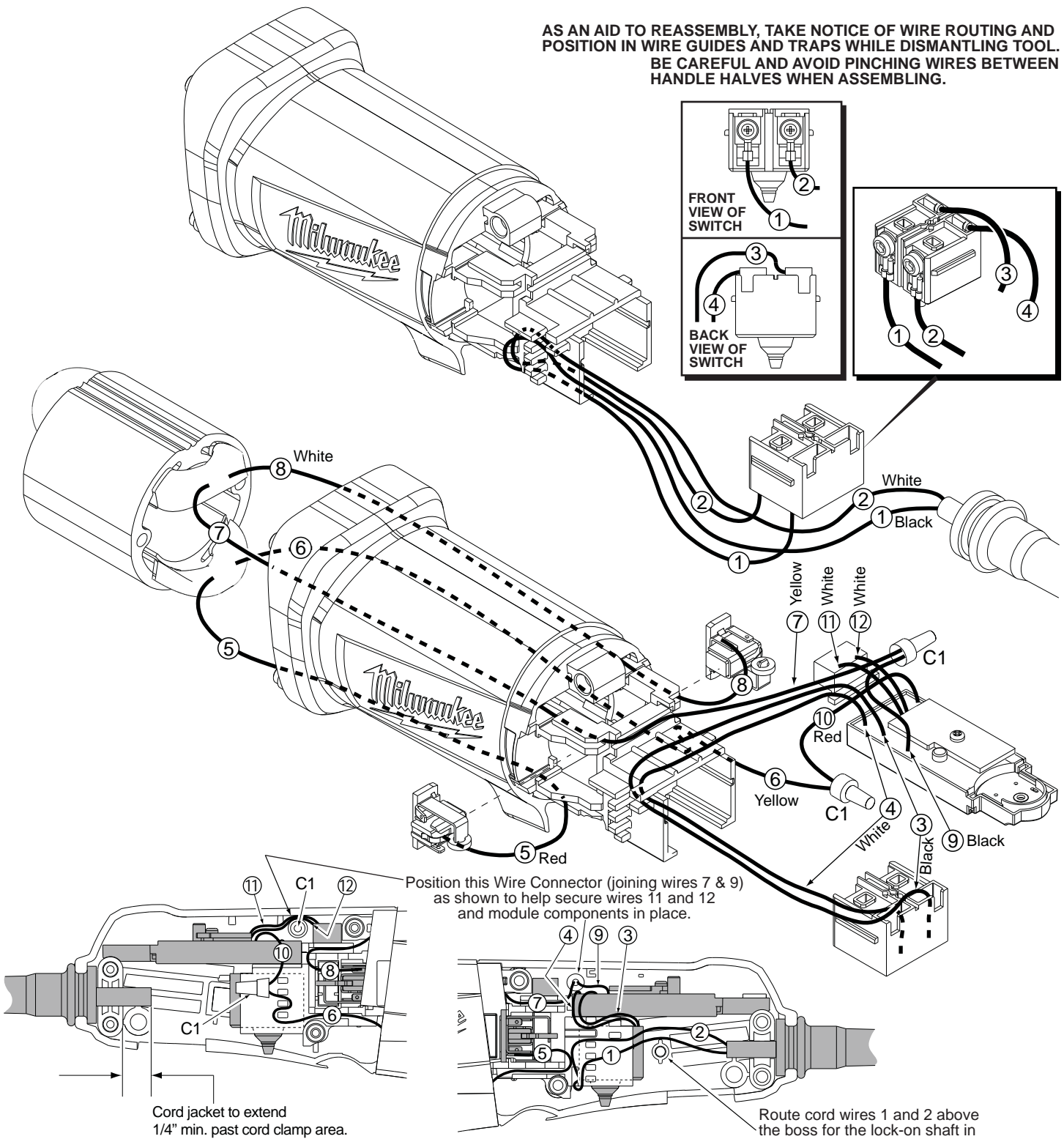

WIRING SPECIFICATIONS

| Wire No. | Wire Color | Origin or Part No. | Gauge | Length | Terminals, Connectors and End Wire Preparation |
|----------|------------|--------------------|-------|--------|--|
| 1 | Black | 22-64-2020 | -- | -- | Component of cord set. |
| 2 | White | 22-64-2020 | -- | -- | Component of cord set. |
| 3 | Black | 22-09-1725 | -- | -- | Component of PC board. |
| 4 | White | 22-09-1725 | -- | -- | Component of PC board. |
| 5 | Red | 18-07-2305 | -- | -- | Component of field. |
| 6 | Yellow | 18-07-2305 | -- | -- | Component of field. |
| 7 | Yellow | 18-07-2305 | -- | -- | Component of field. |
| 8 | White | 18-07-2305 | -- | -- | Component of field. |
| 9 | Black | 22-09-1725 | -- | -- | Component of PC board. |
| 10 | Red | 22-09-1725 | -- | -- | Component of PC board. |
| 11 | White | 22-09-1725 | -- | -- | Component of PC board. |
| 12 | White | 22-09-1725 | -- | -- | Component of PC board. |

BULK LEAD WIRE - BULLETIN 58-01-0003

NOTE:

All leads must be held to $\pm 1/16"$. All lead lengths are before stripping.

| TERMINAL DESCRIPTION | | |
|-----------------------|------------|------|
| Code | Part No. | Qty. |
| | | |
| CONNECTOR DESCRIPTION | | |
| C1 | 22-56-0150 | 2 |