



SERVICE PARTS LIST

BULLETIN NO.
54-38-2270

SPECIFY CATALOG NO. AND SERIAL NO. WHEN ORDERING PARTS		REVISED BULLETIN	DATE
6" HP ANGLE GRINDER with SLIDE SWITCH			May 2012
CAT. NO.	6161-33	STARTING SERIAL NUMBER	D09A
		WIRING INSTRUCTION See Reverse Side	

FIG.	PART NO.	DESCRIPTION OF PART	NO. REQ.
1	05-88-1650	M4 x 25mm Pan Hd. ST Screw T-20	(6)
2	42-62-0125	Side Handle Assembly	(1)
3	14-30-1155	Gearcase Assembly	(1)
3a	-----	Spindle Lock Button	(1)
3b	-----	Spindle Lock Spring	(1)
3c	-----	Gearcase	(1)
3d	-----	O-Ring	(1)
3e	-----	Spindle Lock Pin	(1)
3f	-----	Needle Bearing	(1)
3g	02-04-0620	Ball Bearing	(1)
4	34-40-0560	O-Ring	(1)

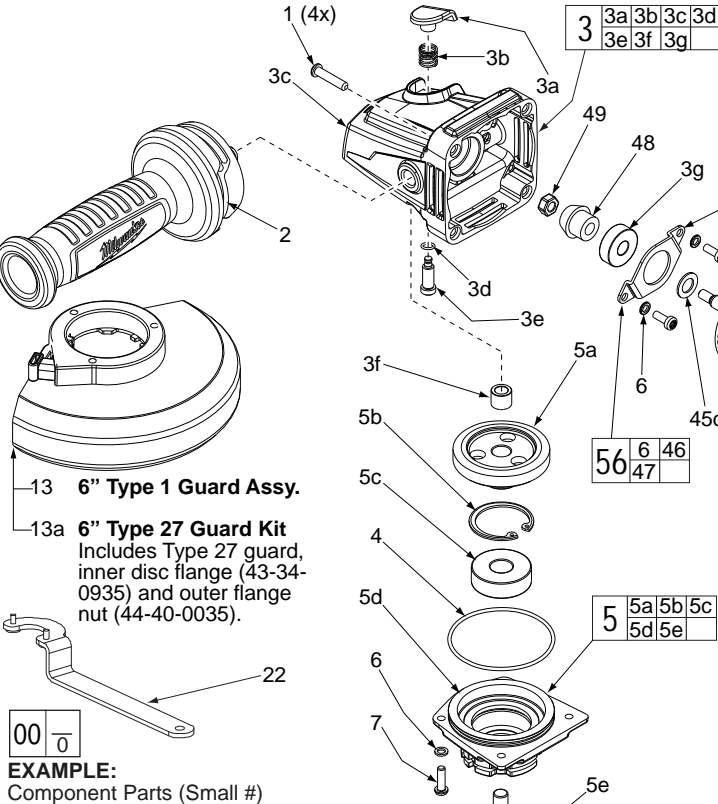

EXAMPLE:
Component Parts (Small #)
Are Included When Ordering
The Assembly (Large #).

***LUBRICATION NOTE:**
When servicing the Gears (5a & 48)
or the Gearcase (3c), 90-95% of the
old grease must be removed prior
to new grease being added.

FIG. LUBRICATION*
5a,48 Type "Y" Grease, No. 49-08-5270,
Must Be Applied To All Gear Teeth.

5	14-73-0430	Spindle Hub Assembly	(1)
5a	-----	Spiral Bevel Gear	(1)
5b	-----	Retaining Ring	(1)
5c	-----	Ball Bearing	(1)
5d	-----	Spindle Hub	(1)
5e	-----	5/8" Spindle	(1)
6	05-90-0225	Spring Washer	(6)
7	05-88-1210	M4 x 14mm Pan Hd. Mach. Screw T-20	(4)
13	14-32-0225	6" Type 1 Guard Assembly	(1)
13a	14-46-0406	6" Type 27 Guard Service Kit with flanges	(1)
15	-----	O-Ring	(1)
16	-----	Wavy Spring	(1)
17	-----	Flange with Ramps	(1)
18	-----	Retaining Ring	(1)
19	43-34-0205	6" T1 Inner Flange (For type 1 wheels only)	(1)
21	44-40-0205	6" T1 Outer Flange (For type 1 wheels only)	(1)
22	49-96-7205	Spanner Wrench	(1)
23	14-34-6120	Rear Handle Set	(1)
23a	-----	Left Handle Halve	(1)
23b	-----	Right Handle Halve	(1)

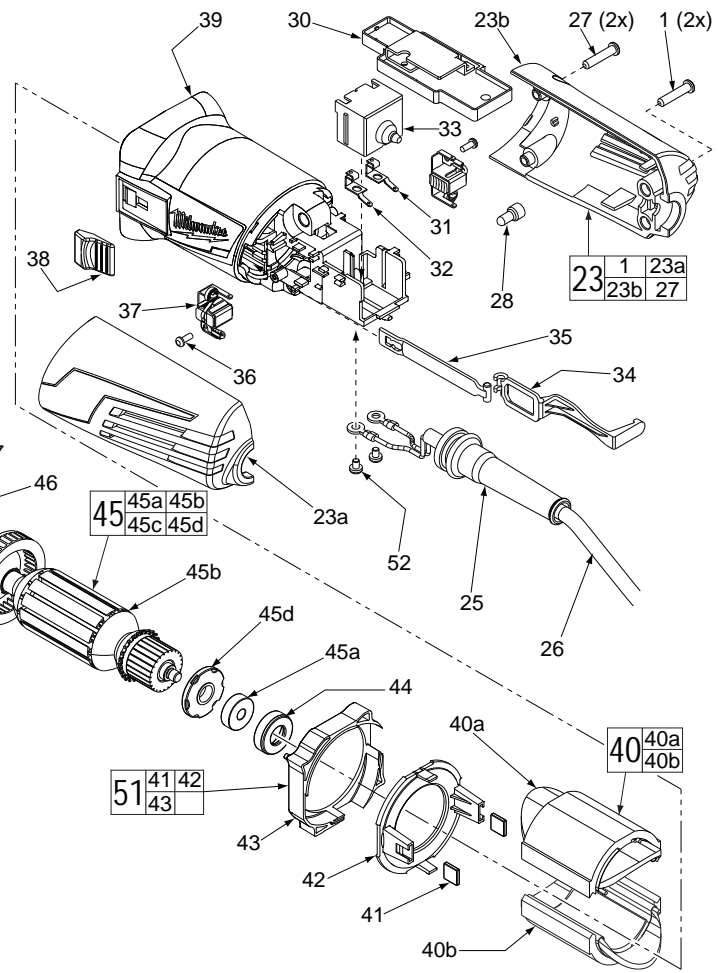
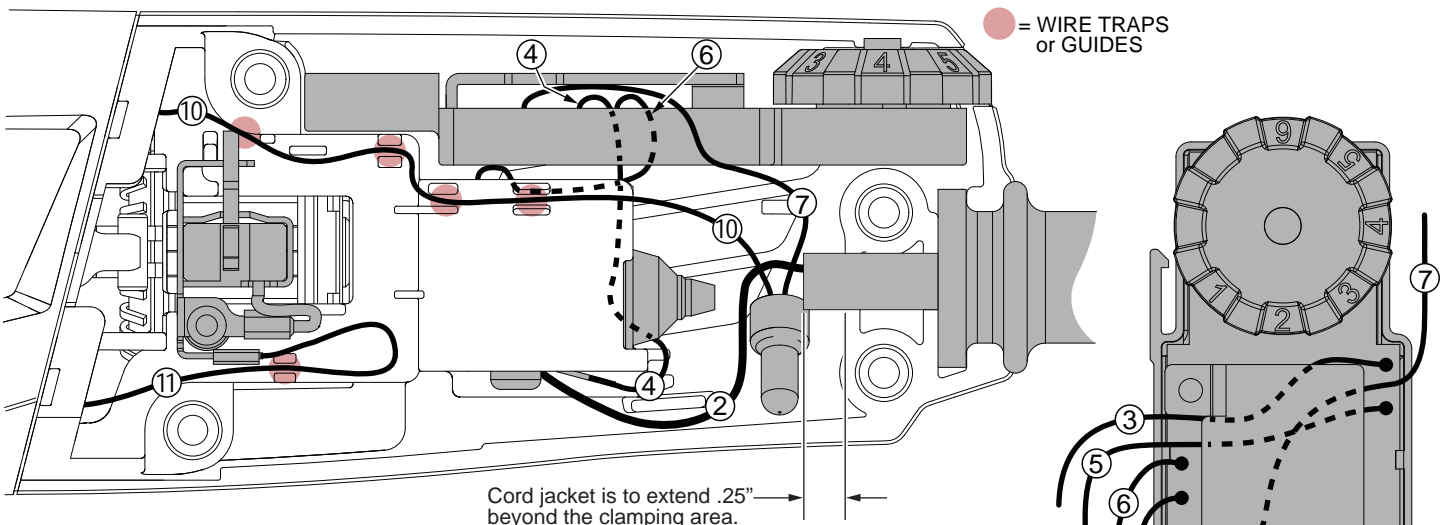
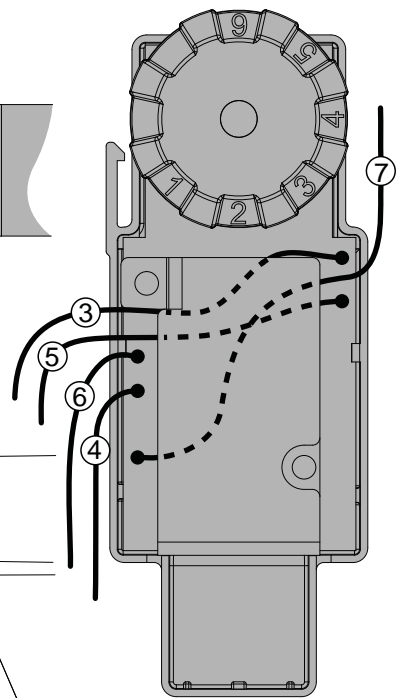

FIG.	PART NO.	DESCRIPTION OF PART	NO. REQ.
25	44-76-0095	Cord Protector	(1)
26	22-64-3430	Power Cord	(1)
27	05-88-1300	M4 x 28mm Pan Hd. ST Screw T-20	(2)
28	22-56-0150	Close End Connector	(1)
30	22-09-1835	PCB Assembly	(1)
31	23-74-1620	Terminal	(1)
32	23-74-1615	Terminal	(1)
33	23-66-2665	On-Off Switch	(1)
34	31-84-0090	Slide Pole - Back	(1)
35	31-84-0095	Slide Pole - Front	(1)
36	05-88-0030	M3 x 8.5mm Pan Hd. ST Screw T-10	(2)
37	22-18-2250	Carbon Brush Assembly (Set of 2)	(1)
38	31-89-0245	Slide Switch Button	(1)
39	31-50-2130	Motor Housing	(1)
40	18-07-0295	Field Assembly	(1)
40a	-----	Field Halve	(1)
40b	-----	Field Halve	(1)
41	42-28-0085	Rubber Block	(2)
42	-----	Baffle Foot	(1)
43	-----	Baffle	(1)
44	42-96-0016	Rubber Bearing Cap	(1)
45	16-10-0845	Armature Assembly	(1)
45a	02-04-2110	Ball Bearing	(1)
45b	-----	Armature	(1)
45c	45-88-0406	Washer	(1)
45d	-----	Magnetic Disc	(1)
46	05-88-1280	M4 x 10mm Pan Hd. Mach. Screw T-20	(2)
47	44-86-0155	Bearing Retainer	(1)
48	32-60-0305	Pinion	(1)
49	05-55-0620	M5 Hex Nut	(1)
50	14-46-6105	Flange with Ramps Assembly	(1)
51	42-14-0515	Baffle Assembly	(1)
52	05-78-0305	M3.5 x 7mm Pan Hd. Phil. Switch Scr.	(2)
56	44-86-0145	Bearing Retaining Plate Assembly	(1)
	12-20-1560	Service Nameplate (Not Shown)	(1)
	10-20-2225	Bi-Lingual Warning Label (Not Shown)	(1)



Cord jacket is to extend .25" beyond the clamping area.



TOP VIEW OF THE PCB ASSEMBLY

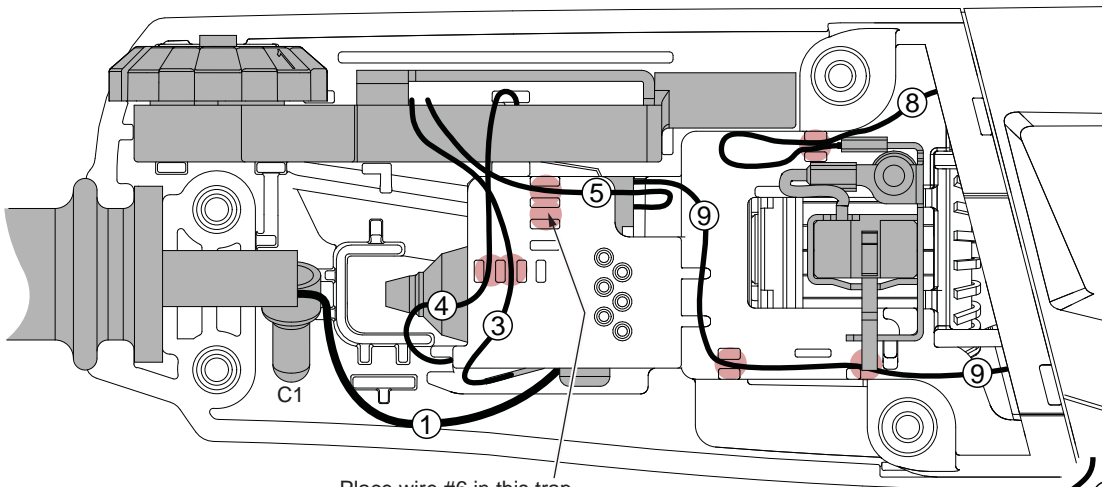

Place wire #6 in this trap. See view above for wire routing.

NOTE- ILLUSTRATIONS ABOVE DEPICT A TOOL WITH A SPEED DIAL ON THE PCB ASSEMBLY. MODELS THAT DO NOT HAVE THE SPEED DIAL FEATURE ON THE PCBA ARE WIRED EXACTLY THE SAME.

AS AN AID TO REASSEMBLY, TAKE NOTICE OF WIRE ROUTING AND POSITION IN WIRE GUIDES AND TRAPS WHILE DISMANTLING TOOL.

BE CAREFUL AND AVOID PINCHING WIRES BETWEEN HANDLE HALVES WHEN ASSEMBLING.

NOTE:
Install the two terminals onto switch and slide the switch down into the motor housing prior to installing cord wires 1 and 2 and PCBA wires 3 and 6 from under motor housing.

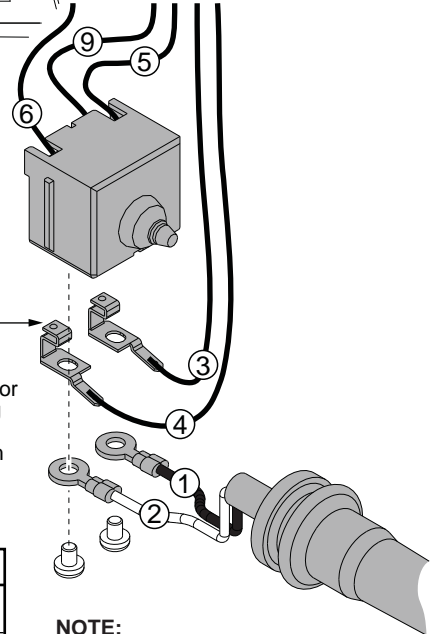

NOTE:
All leads must be held to $\pm 1/16"$.
All lead lengths are before strip-

WIRING SPECIFICATIONS

Wire No.	Wire Color	Origin or Part No.	Gauge	Length	Terminals, Connectors and End Wire Preparation
1	Black	22-64-3430	--	--	Component of Cord Set. Connect to Switch.
2	White	22-64-3430	--	--	Component of Cord Set. Connect to Switch.
3	Black	22-09-1835	--	--	Component of PCBA. Connect to Switch.
4	White	22-09-1835	--	--	Component of PCBA. Connect to Switch.
5	Black	22-09-1835	--	--	Component of PCBA. Connect to Switch.
6	White	22-09-1835	--	--	Component of PCBA. Connect to Switch.
7	Red	22-09-1835	--	--	Component of PCBA. Connect to C1 with wire #10.
8	White	18-07-0295	--	--	Component of Field. Connect to Right Brush Assy.
9	White	18-07-0295	--	--	Component of Field. Connect to Switch.
10	White	18-07-0295	--	--	Component of Field. Connect to C1 with wire #7.
11	White	18-07-0295	--	--	Component of Field. Connect to Left Brush Assy.

BULK LEAD WIRE - BULLETIN 58-01-0003

TERMINAL DESCRIPTION

Code	Part No.	Qty.

CONNECTOR DESCRIPTION

C1	22-56-0150	1
----	------------	---