



SERVICE PARTS LIST

BULLETIN NO.
55-40-0680

SPECIFY CATALOG NO. AND SERIAL NO. WHEN ORDERING PARTS		REVISED BULLETIN	DATE
14" ABRASIVE CUT-OFF MACHINE			Feb. 2013
CATALOG NO. 6177-59A	STARTING SERIAL NO. C79A	WIRING INSTRUCTION 58-03-0552	

EXAMPLE:
00 0 Component Parts (Small #) Are Included
When Ordering The Assembly (Large #).

FIG.	PART NO.	DESCRIPTION OF PART	NO REQ.
1	05-75-0065	M10 x 17 Hex Bolt	(2)
23	28-50-0020	Upper Arm	(1)
41	44-76-0104	Grommet	(1)
50	45-88-8495	6mm Flat Washer	(4)
51	05-90-0185	6mm Spring Washer	(2)
69	42-12-0425	Shaft	(1)
70	45-88-8905	10mm Flat Washer	(3)
71	05-90-0205	10mm Spring Washer	(2)
72	05-55-0135	M10 Nut	(2)
76	45-84-0130	Rear Vise	(1)
78	05-86-0800	M8 x 13 Bolt	(3)
79	05-55-0140	M8 Hex Nut	(1)
80	42-30-0415	Stopper Body	(1)
81	45-96-0100	Wrench	(1)
82	42-42-0465	Lock Button	(1)
83	34-40-0091	O-Ring	(1)
85	44-50-0175	Lock Down Pin	(1)
86	05-55-0125	M6 Nut	(2)
88	05-74-0745	M6 x 16 Bolt	(4)
89	45-22-0690	Sleeve	(2)
90	43-54-0910	Spark Guard	(1)
91	40-50-1295	Torsion Spring	(1)
96	06-65-0017	Cotter Pin	(1)
97	44-64-0020	Vise Shaft	(1)
98	45-84-0135	Clamp Fence	(1)
99	45-88-8421	10mm Flat Washer	(1)
100	05-55-0145	M8 Nylon Hex Nut	(1)
101	05-90-0210	8mm Spring Washer	(2)
102	45-88-8915	8mm Flat Washer	(2)
103	44-40-0016	Release Nut	(1)
104	06-65-0019	Roll Pin	(1)
105	45-07-0010	Seat	(1)
106	45-84-0140	Screw Bar Assembly	(1)
109	31-06-0016	Base	(1)
110	44-34-0018	Rubber Foot	(3)
117	12-20-6177	Service Nameplate	(1)
118	06-72-1720	Nameplate Rivet	(4)
119	10-20-7303	Warning Label	(1)

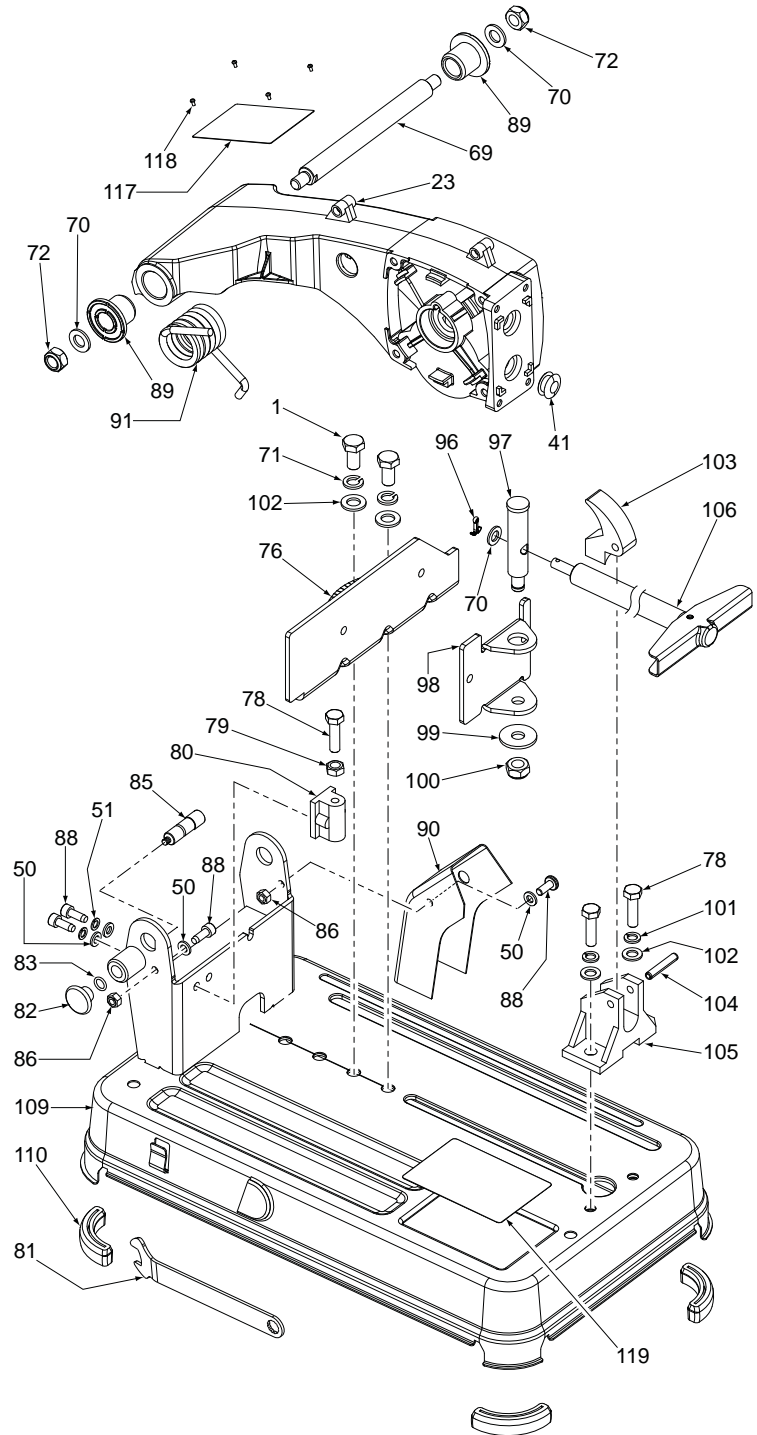

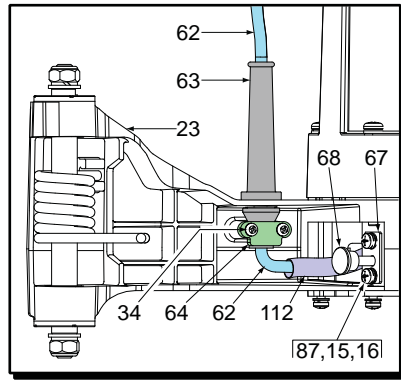

BOTTOM VIEW OF ARM (23)

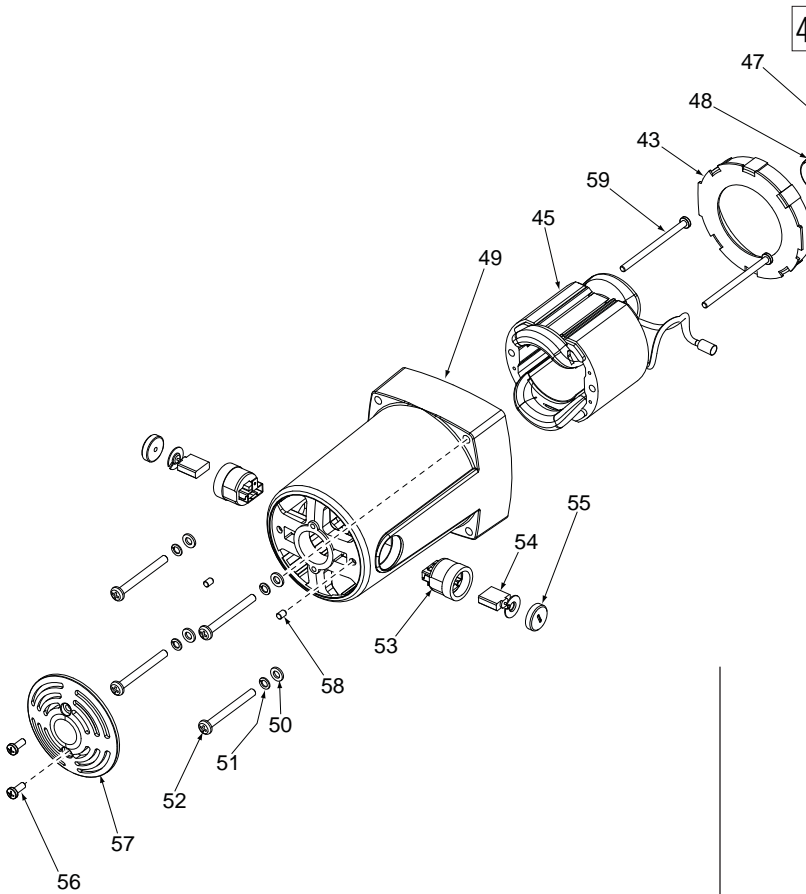

FIG.	PART NO.	DESCRIPTION OF PART	NO REQ.
15	05-90-0190	5mm Spring Washer	(6)
16	45-88-8485	5mm Flat Washer	(6)
23	28-50-0020	Upper Arm	(1)
24	05-81-0811	M5 x 13 Pan Hd. Plast. Screw	(2)
25	05-81-0776	M4 x 16 Pan Hd. Plast. ST Screw	(2)
26	31-44-3220	Carrying Handle - Right	(1)
27	31-44-3225	Carrying Handle - Left	(1)
28	05-55-0030	M5 Hex Nut	(2)
29	22-33-0100	Capacitor	(1)
30	31-44-3230	Handle - Right	(1)
31	05-81-0522	M5 x 20 Pan Hd. Screw	(4)
32	-----	Retaining Ring	(1)
34	05-81-0432	M4 x 13 Pan Hd. Screw	(2)
35	05-78-0428	M4 x 16 Pan Hd. Plast. ST Screw	(3)
36	31-44-3235	Handle - Left	(1)
38	05-78-0427	M4 x 10 Pan Hd. Plast. ST Screw	(1)
39	23-66-1425	Switch	(1)

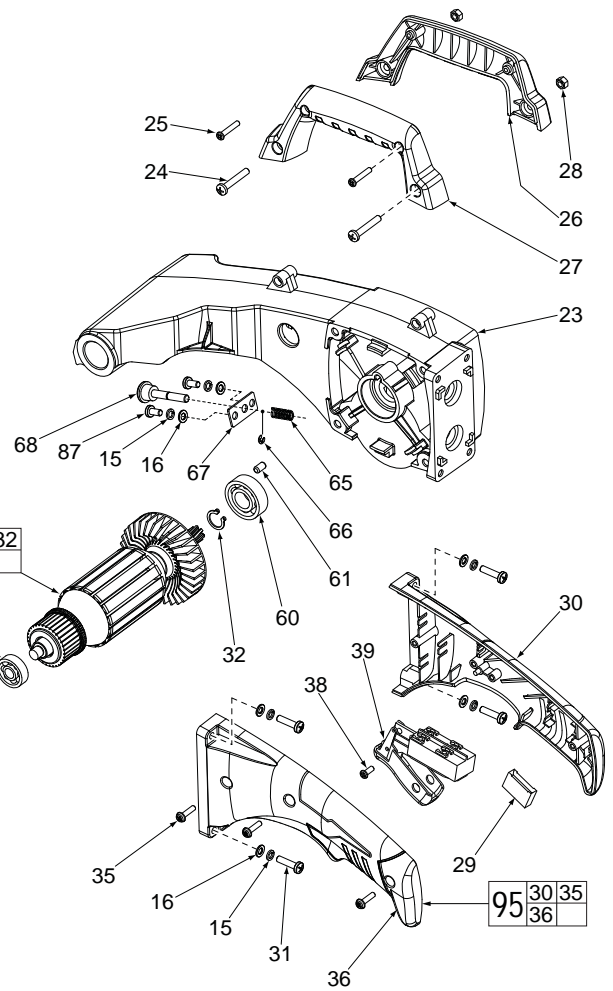

FIG.	PART NO.	DESCRIPTION OF PART	NO REQ.
43	31-05-0016	Baffle	(1)
45	18-74-0190	230 V Field	(1)
46	16-74-0200	230 V Armature	(1)
47	02-04-0016	Ball Bearing	(1)
48	45-22-0725	Bearing Sleeve	(1)
49	31-50-0025	Motor Housing	(1)
50	45-89-8495	6mm Flat Washer	(4)
51	05-90-0185	6mm Spring Washer	(4)
52	05-81-0521	M6 x 60 Pan Hd. Screw	(4)
53	22-20-0017	Brush Holder	(2)
54	22-18-0590	230 V Brush	(2)
55	22-24-0027	Brush Cap	(2)
56	05-81-0476	M5 x 13 ST Screw	(2)
57	31-15-0515	End Cap	(1)
58	05-81-0495	M5 x 8 Set Screw	(2)
59	05-81-0681	M5 x 80 ST Screw	(2)
60	02-04-0026	Ball Bearing	(1)
61	44-60-1900	Rubber Pin	(1)
62	22-64-1453	Power Cord	(1)
63	44-76-0061	Cord Protector	(1)
64	44-76-0065	Cord Clamp	(1)
65	40-50-0136	Lock Pin Spring	(1)
66	34-60-0015	Retaining Ring	(1)
67	42-36-0056	Plate	(1)
68	44-60-0061	Lock Pin Assembly	(1)
87	05-81-0431	M5 x 10 Screw	(2)
95	14-46-3200	Operating Handle Kit	(1)
112	23-48-0105	Insulation Sleeve	(1)

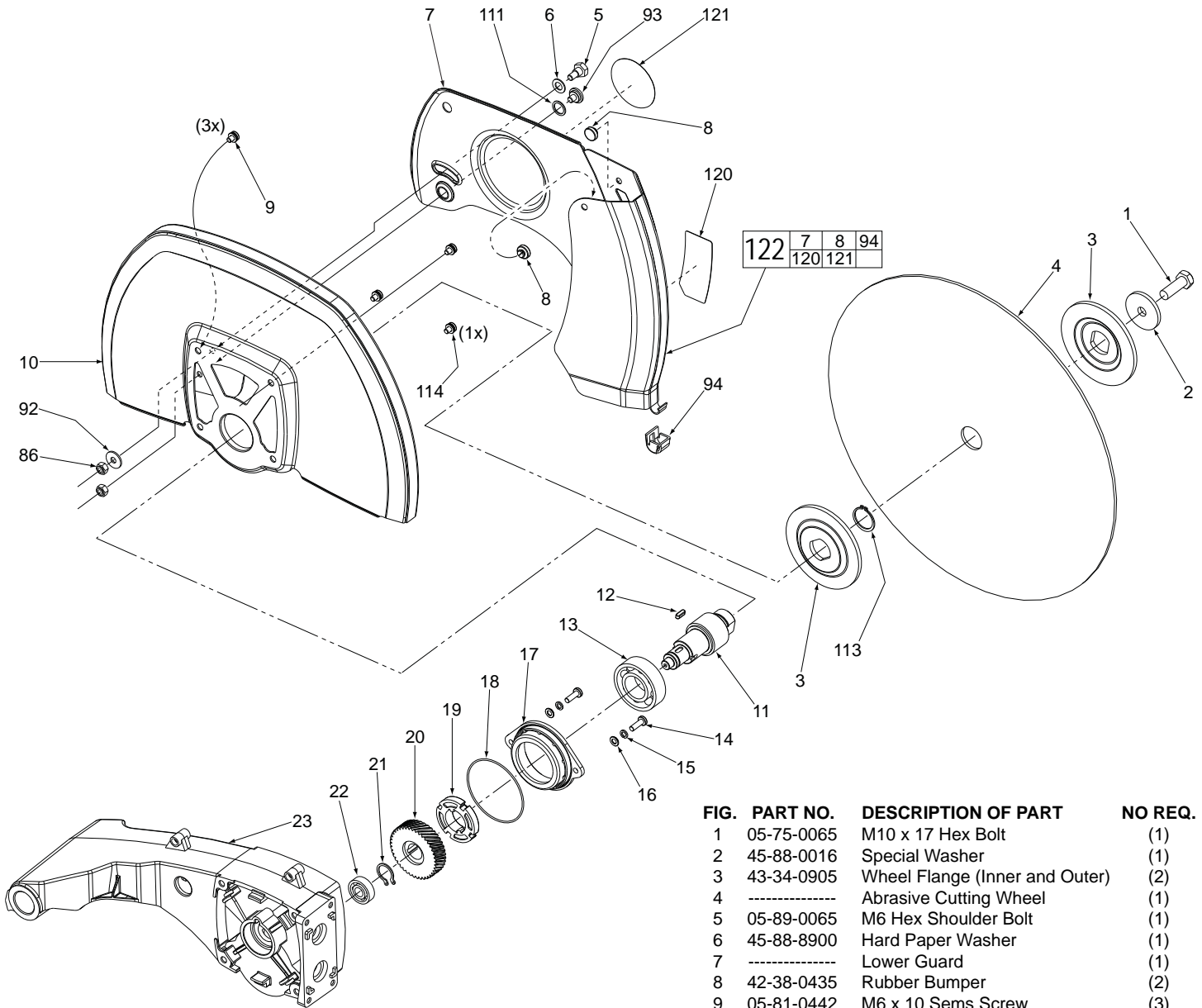

FIG.	PART NO.	DESCRIPTION OF PART	NO REQ.
1	05-75-0065	M10 x 17 Hex Bolt	(1)
2	45-88-0016	Special Washer	(1)
3	43-34-0905	Wheel Flange (Inner and Outer)	(2)
4	-----	Abrasive Cutting Wheel	(1)
5	05-89-0065	M6 Hex Shoulder Bolt	(1)
6	45-88-8900	Hard Paper Washer	(1)
7	-----	Lower Guard	(1)
8	42-38-0435	Rubber Bumper	(2)
9	05-81-0442	M6 x 10 Sems Screw	(3)
10	43-54-0905	Upper Guard	(1)
11	38-50-0056	Spindle	(1)
12	05-42-0016	4 x 4 x 12 Key	(1)
13	02-04-0046	Ball Bearing	(1)
14	05-81-0120	M5 x 20 Pan Hd. Screw	(2)
15	05-90-0190	5mm Spring Washer	(2)
16	45-88-8485	5mm Flat Washer	(2)
17	43-34-0900	Bearing Flange	(1)
18	34-40-0090	O-Ring	(1)
19	42-74-0063	Wheel Lock	(1)
20	32-75-0016	Gear	(1)
21	05-92-0056	Retaining Ring	(1)
22	02-04-0036	Ball Bearing	(1)
23	28-50-0020	Upper Arm	(1)
86	05-55-0125	M6 Nut	(2)
92	45-88-8910	M6 Special Washer (Flat)	(1)
93	05-89-0080	M6 Shoulder Screw	(1)
94	42-52-0040	Lower Guard Cap	(1)
111	45-88-8925	Washer	(1)
113	34-60-0018	Retaining Ring	(1)
114	05-81-0441	M6 x 18 Sems Screw	(1)
120	10-20-7304	Lower Guard Label	(1)
121	10-20-7305	Round Lower Guard Label	(1)
122	43-54-0901	Lower Guard Assembly	(1)
	49-08-5270	Type 'Y' Grease (6 oz. Tube)	(1)
		(23-27 grams, approx. 7/8 oz. needed)	