

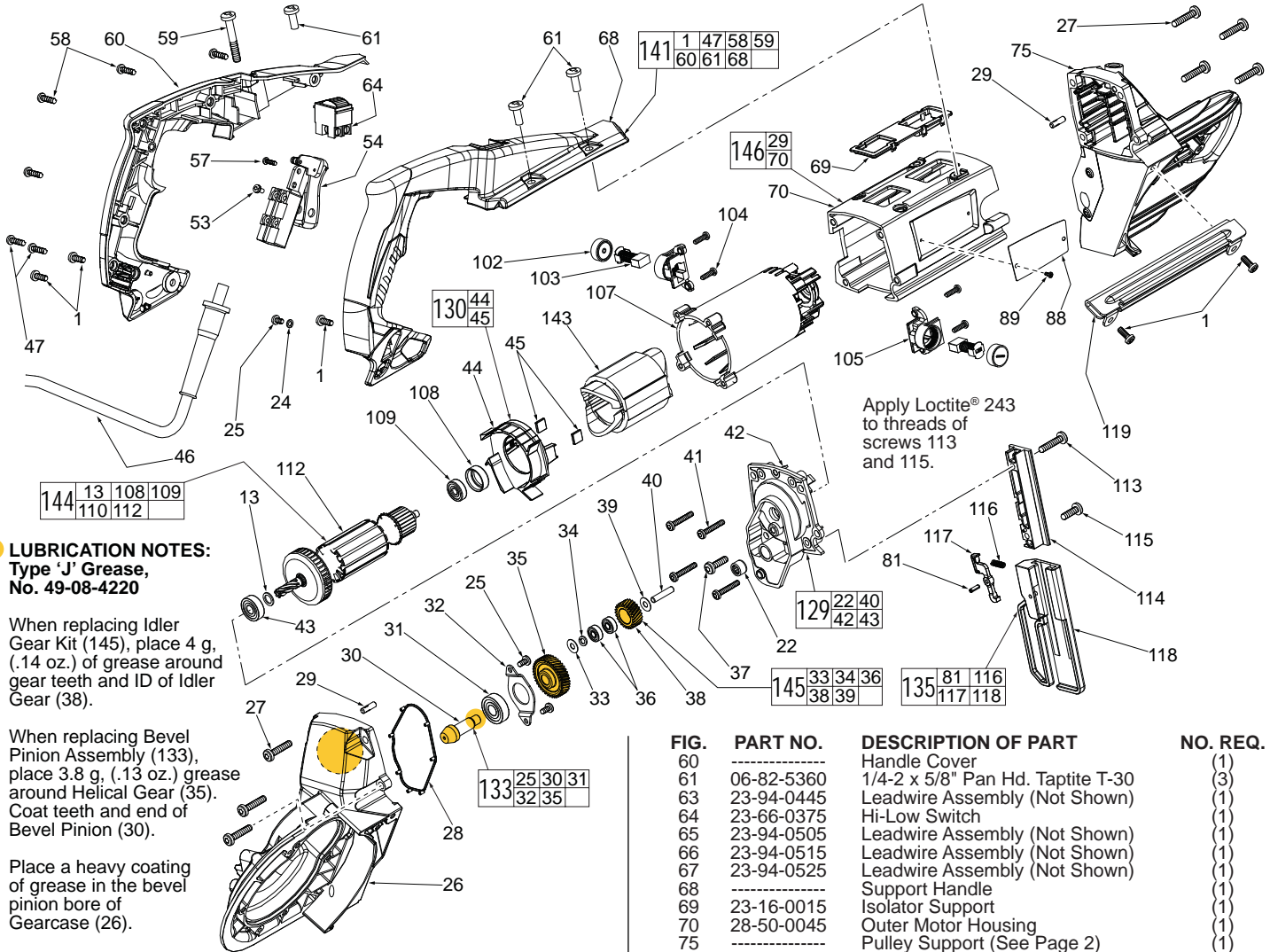

SERVICE PARTS LIST

BULLETIN NO.
54-40-6250

SPECIFY CATALOG NO. AND SERIAL NO. WHEN ORDERING PARTS		REVISED BULLETIN	DATE
DEEP CUT AC/DC BANDSAW			Oct. 2014
CATALOG NO. 6238-21	STARTING SERIAL NO. D52A	WIRING INSTRUCTION See Page 4 thru 6	



LUBRICATION NOTES:
Type 'J' Grease,
No. 49-08-4220

When replacing Idler Gear Kit (145), place 4 g. (.14 oz.) of grease around gear teeth and ID of Idler Gear (38).

When replacing Bevel Pinion Assembly (133), place 3.8 g. (.13 oz.) grease around Helical Gear (35). Coat teeth and end of Bevel Pinion (30).

Place a heavy coating of grease in the bevel pinion bore of Gearcase (26).

FIG.	PART NO.	DESCRIPTION OF PART	NO. REQ.
1	06-82-5314	10-24 x 1/2" Pan Hd. Tapt. T-25 (5 of 23)	(23)
13	45-88-0406	Washer (1 of 2)	(2)
22	-----	Needle Bearing (1 of 3)	(3)
24	05-90-0225	Washer	(1)
25	06-82-8828	8-32 x .313" Pan Hd. Taptite T-20	(3)
26	-----	Gearcase (See Page 3)	(1)
27	06-82-5376	12-24 x 1" Pan Hd. Taptite T-27	(7)
28	34-40-0185	Seal Gasket	(1)
29	-----	Pin	(2)
30	-----	Bevel Pinion	(1)
31	-----	Ball Bearing	(1)
32	-----	Bearing Plate	(1)
33	45-88-0895	Washer	(1)
34	45-88-6230	Spring Washer	(1)
35	-----	Helical Gear	(1)
36	-----	Ball Bearing	(2)
37	06-82-5358	12-24 x 3/4" Pan Hd. Taptite T-27	(1)
38	-----	Idler Gear	(1)
39	45-88-6232	Washer	(1)
40	-----	Pin	(1)
41	06-82-7326	8-16 x 1" Pan Hd. Plastite T-20	(4)
42	-----	Diaphragm	(1)
43	02-04-0175	Ball Bearing (1 of 2)	(2)
44	-----	Baffle	(1)
45	42-28-0085	Rubber Block	(2)
46	22-64-0465	Power Cord	(1)
47	06-82-7409	8-16 x 1/2" Pan Hd. Plastite T-20	(2)
53	05-78-0305	M3.5 x 7mm Pan Hd. Screw	(4)
54	23-66-2726	On-Off Switch	(1)
57	06-82-7251	8-16 x 3/8" Pan Hd. Taptite	(1)
58	06-82-7270	8-16 x 5/8" Pan Hd. Plastite T-20	(4)
59	06-82-0125	1/4-20 x 1.65" Pan Hd. Taptite T-30	(1)

FIG.	PART NO.	DESCRIPTION OF PART	NO. REQ.
60	-----	Handle Cover	(1)
61	06-82-5360	1/4-2 x 5/8" Pan Hd. Taptite T-30	(3)
63	23-94-0445	Leadwire Assembly (Not Shown)	(1)
64	23-66-0375	Hi-Low Switch	(1)
65	23-94-0505	Leadwire Assembly (Not Shown)	(1)
66	23-94-0515	Leadwire Assembly (Not Shown)	(1)
67	23-94-0525	Leadwire Assembly (Not Shown)	(1)
68	-----	Support Handle	(1)
69	23-16-0015	Isolator Support	(1)
70	28-50-0045	Outer Motor Housing	(1)
75	-----	Pulley Support (See Page 2)	(1)
81	06-65-0115	Coiled Pin (1 of 3)	(3)
88	12-20-6232	Service Nameplate	(1)
89	-----	Nameplate Screw	(2)
102	23-44-0220	Brush Cap	(2)
103	22-18-0025	Carbon Brush	(2)
104	05-88-1360	M4 x 13.5mm ST Screw	(4)
105	22-20-0080	Brush Holder Assembly	(2)
107	31-50-0305	Inner Motor Housing	(1)
108	42-96-0016	Bearing Cap	(1)
109	02-04-0645	Ball Bearing	(1)
112	-----	Armature	(1)
113	06-82-0065	10-32 x 1" Pan Hd. Taptite T-25	(1)
114	30-13-0015	T-Block	(1)
115	06-82-5330	10-32 x 5/8" Pan Hd. Taptite T-25	(1)
116	40-50-0845	Lever Release Spring	(1)
117	42-42-0060	Release Button	(1)
118	-----	Shoe Bumper	(1)
119	43-54-0085	Blade Guard	(1)
129	14-13-0010	Diaphragm Kit	(1)
130	42-14-0015	Fan Baffle Kit	(1)
133	32-60-0095	Bevel Pinion Assembly	(1)
135	42-18-0035	Shoe Bumper Kit	(1)
141	31-44-0785	Handle Assembly Kit	(1)
143	18-07-0045	Service Field Kit	(1)
144	16-10-0035	Service Armature Kit	(1)
145	32-60-6230	Idler Gear Kit	(1)
146	14-30-6230	Outer Motor Housing Kit	(1)

SEE PAGE 3 FOR FASTENER TORQUE CHART

00 0

EXAMPLE:
Component Parts
(Small #) Are Included
When Ordering The
Assembly (Large #).

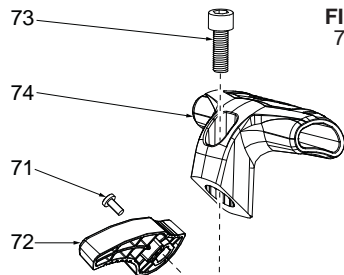

FIG. 73 NOTE:
Use Loctite® 243 or the equivalent to the threads of Screw (73) prior to installing T-Handle (74) onto Pulley Support (75).

FIG. 75,90 NOTE:
Use Loctite® 326 or the equivalent to secure the Blade Backing Pad (90) to the Pulley Support (75).

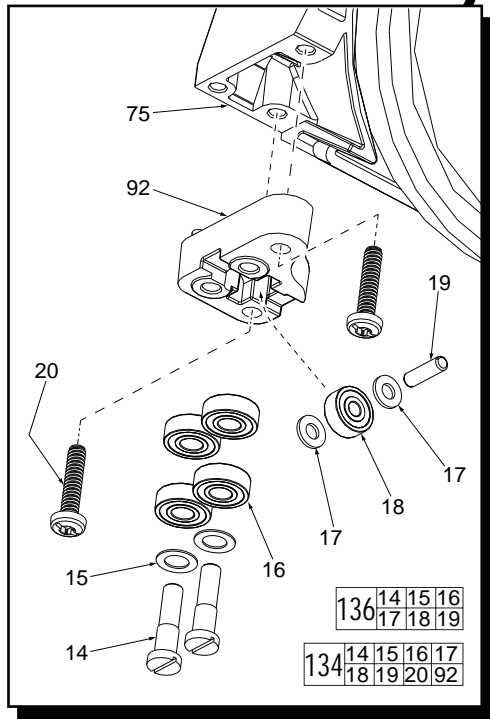
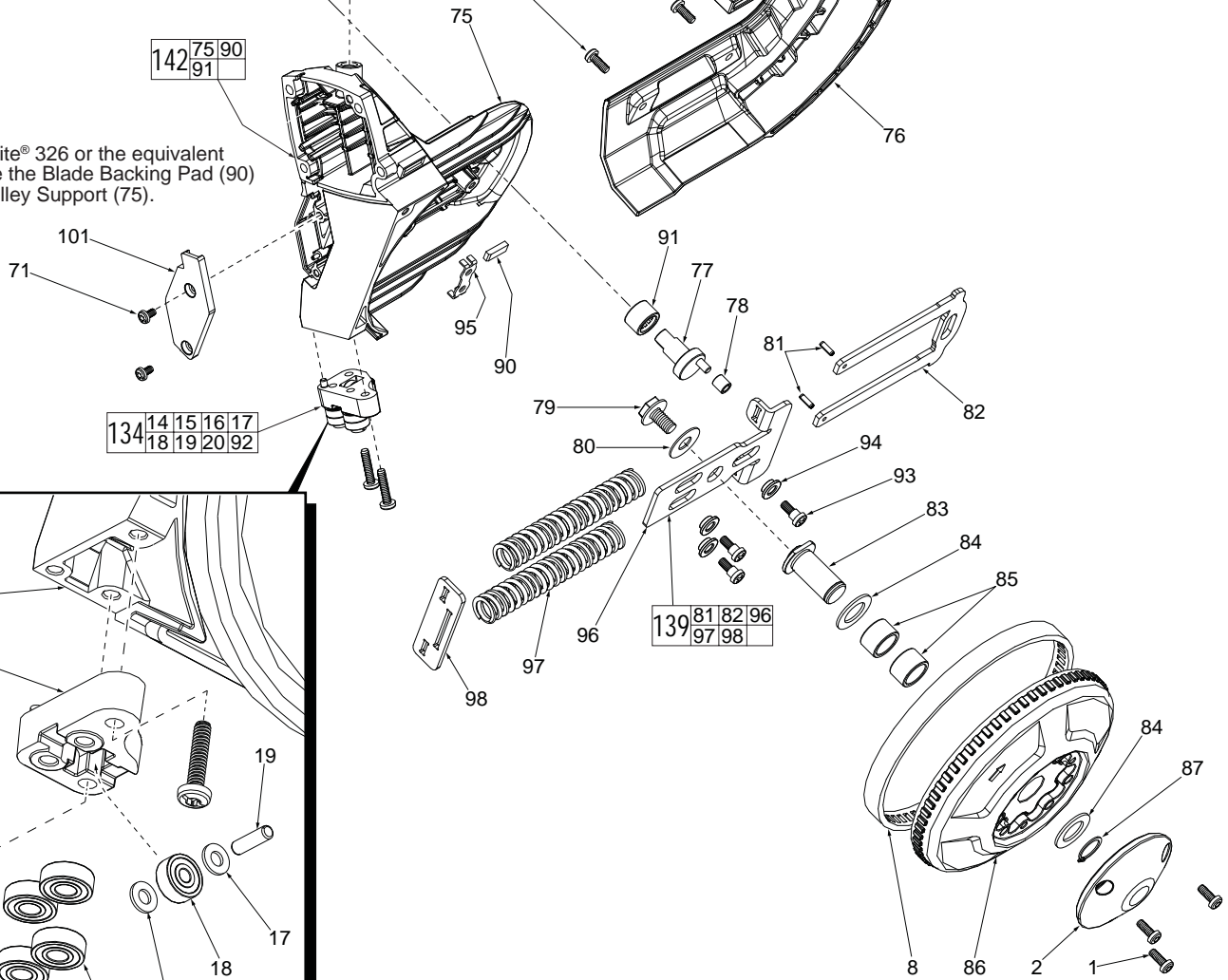

FIG.	PART NO.	DESCRIPTION OF PART	NO. REQ.
1	06-82-5314	10-24 x 1/2" Pan Hd. Tapt. T-25 (7 of 23) (23)	(23)
2	31-15-0325	Pulley Cover (1 of 2)	(2)
8	45-69-0010	Pulley Tire (1 of 2)	(2)
14	-----	12-24 UNC x .96" Slotted (2 of 4)	(4)
15	-----	Washer (2 of 4)	(4)
16	-----	Ball Bearing (4 of 8)	(8)
17	-----	Washer (2 of 4)	(4)
18	-----	Ball Bearing (1 of 2)	(2)
19	-----	Pin (1 of 2)	(2)
20	06-82-5574	10-24 x 7/8" Pan Hd. Tapt. T-25 (2 of 4)	(4)
71	06-82-7252	8-32 x .38" Pan Hd. Taptite T-20	(3)
72	31-52-0065	Tension Release Lever	(1)
73	06-75-4675	3/8"-16 UNC x 1" Socket Hd. Cap Screw	(1)
74	31-44-0740	Front T-Handle	(1)
75	-----	Pulley Support	(1)
76	31-15-0335	Front Pulley Shroud	(1)
77	45-08-0070	Cam Shaft	(1)
78	42-40-0105	Cam Bushing	(1)
79	06-75-0035	5/16-18 x 9/16" Screw	(1)
80	45-88-0395	Washer	(1)

FIG.	PART NO.	DESCRIPTION OF PART	NO. REQ.
81	06-65-0115	Coil Pin (2 of 3)	(3)
82	-----	Driver Plate	(1)
83	42-12-0010	Front Pulley Shaft	(1)
84	45-88-7165	Washer	(2)
85	42-40-0580	Sleeve Bearing	(2)
86	28-95-0050	Front Pulley	(1)
87	34-60-1400	Snap Ring	(1)
90	44-52-0120	Blade Backing Pad	(1)
91	02-50-0035	Needle Bearing	(1)
92	-----	Front Roller Block	(1)
93	06-81-0075	Shoulder Screw	(3)
94	42-40-0115	Tension Bushing	(3)
95	44-66-6232	Wear Plate	(1)
96	-----	Support Plate	(1)
97	-----	Blade Tension Spring	(2)
98	-----	Contact Plate	(1)
101	31-15-0355	LED Cover	(1)
134	42-24-0015	Front Guide Roller Kit	(1)
136	14-46-0465	Guide Roller Kit	(1)
139	42-18-0015	Tensioning Mechanism Assembly	(1)
142	14-30-0060	Pulley Support Kit	(1)

SEE PAGE 3 FOR FASTENER TORQUE CHART

LUBRICATION NOTES:
Type 'J' Grease, No. 49-08-4220

When installing Gearcase Cover Kit (140), place 4.8 g (.16 oz) grease to the Bevel Gear (120). Place 6 g (.21 oz.) to the large Spur Gear (12).

Coat Washer (13) and ends of shafts (9 & 122) with J Grease.

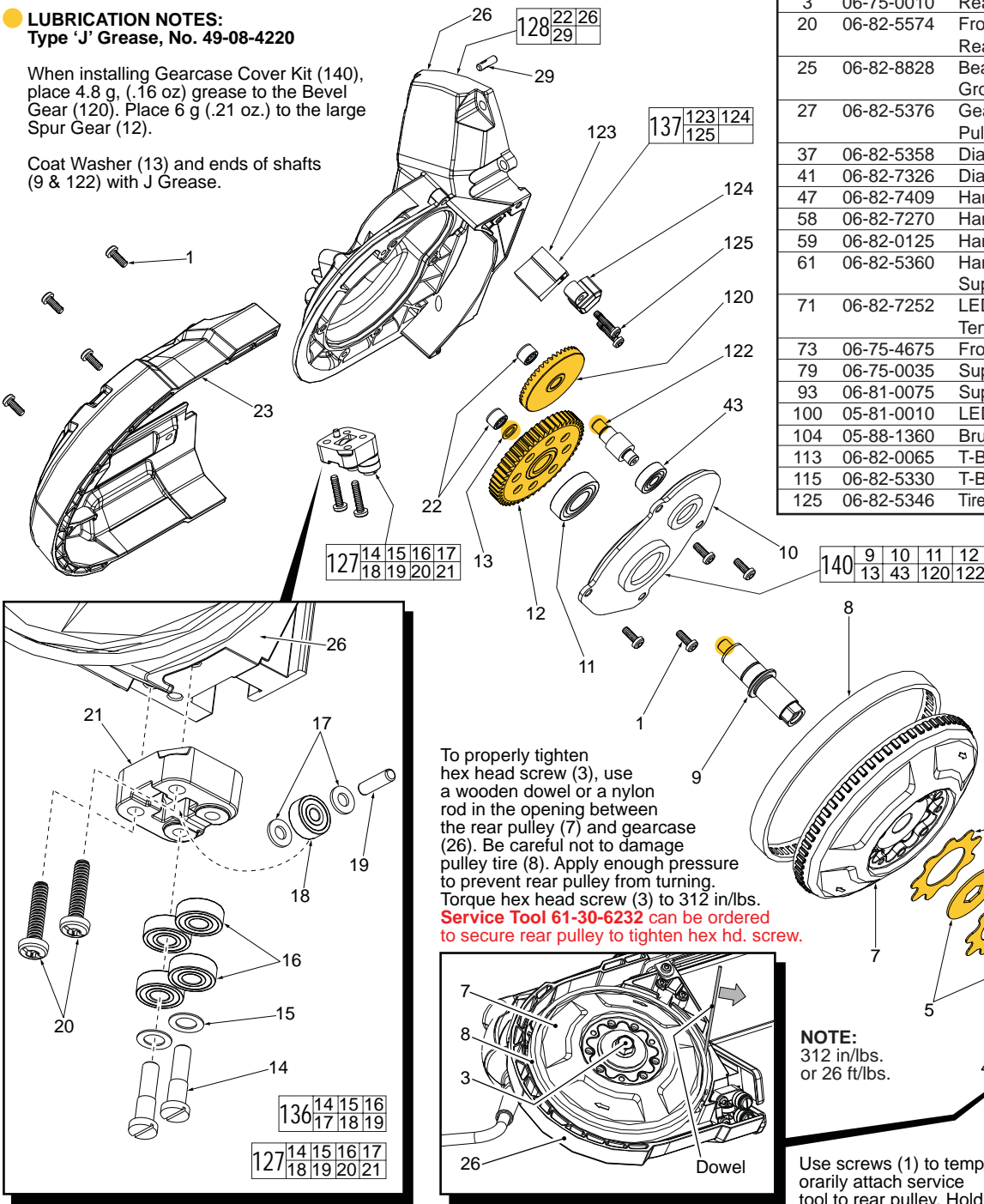

SCREW TORQUE CHART			
Fig.	Part No.	Location	Torque (In/Lbs.)
3	06-75-0010	Rear Pulley	312
20	06-82-5574	Front Roller Block	39
		Rear Roller Block	39
25	06-82-8828	Bearing Plate	17
		Ground Terminal	17
27	06-82-5376	Gearcase	
		Pulley Support	38
37	06-82-5358	Diaphragm	38
41	06-82-7326	Diaphragm	16
47	06-82-7409	Handle Cover	17
58	06-82-7270	Handle Cover	17
59	06-82-0125	Handle Cover	39
61	06-82-5360	Handle Cover	39
		Support Handle	39
71	06-82-7252	LED Cover	
		Tension Release Lever	22
73	06-75-4675	Front T-Handle	83
79	06-75-0035	Support Plate	104
93	06-81-0075	Support Plate	36
100	05-81-0010	LED Assembly	6
104	05-88-1360	Brush Holder Assembly	5
113	06-82-0065	T-Block	19
115	06-82-5330	T-Block	19
125	06-82-5346	Tire Cleaning Brush Cover	22

EXAMPLE:
Component Parts (Small #) Are Included When Ordering The Assembly (Large #).

To properly tighten hex head screw (3), use a wooden dowel or a nylon rod in the opening between the rear pulley (7) and gearcase (26). Be careful not to damage pulley tire (8). Apply enough pressure to prevent rear pulley from turning. Torque hex head screw (3) to 312 in/lbs. **Service Tool 61-30-6232 can be ordered to secure rear pulley to tighten hex hd. screw.**

Lightly coat both sides of Washers (5) and Clutch Plates (6) with J Grease.

NOTE:
312 in/lbs. or 26 ft/lbs.

Use screws (1) to temporarily attach service tool to rear pulley. Hold tool and tightened hex head screw (3) to 312 in/lbs. **Service Tool 61-30-6232**

FIG.	PART NO.	DESCRIPTION OF PART	NO. REQ.
1	06-82-5314	10-24 x 1/2" Pan Hd. Tapt. T25 (11 of 23)(23)	(2)
2	31-15-0325	Pulley Cover (1 of 2)	(2)
3	06-75-0010	M Screw, 3/8"-16 UNC 5/8" Hex Hd.	(1)
4	40-50-0805	Disc Spring	(1)
5	43-06-0010	Clutch Washer	(2)
6	43-06-0015	Clutch Plate	(2)
7	28-95-0040	Rear Pulley	(1)
8	45-69-0010	Pulley Tire (1 of 2)	(2)
9	-----	Spindle	(1)
10	-----	Gearcase Cover	(1)
11	-----	Ball Bearing	(1)
12	-----	Spur Gear	(1)
13	45-88-0406	Washer (1 of 2)	(2)
14	-----	12-24 UNC x .96" Slotted (2 of 4)	(4)
15	-----	Washer (2 of 4)	(4)
16	-----	Ball Bearing (4 of 8)	(8)
17	-----	Washer (2 of 4)	(4)
18	-----	Ball Bearing (1 of 2)	(2)
19	-----	Pin (1 of 2)	(2)
20	06-82-5574	10-24 x 7/8" Pan Hd. Tapt. T-25 (2 of 4)	(4)

FIG.	PART NO.	DESCRIPTION OF PART	NO. REQ.
21	-----	Rear Roller Block	(1)
22	-----	Needle Bearing (2 of 3)	(3)
23	31-15-0330	Rear Pulley Shroud	(1)
26	-----	Gearcase	(1)
29	-----	Pin (1 of 2)	(2)
43	02-04-0175	Ball Bearing (1 of 2)	(2)
120	-----	Bevel Gear	(1)
122	-----	Shaft	(1)
123	-----	Tire Cleaning Brush	(1)
124	-----	Tire Cleaning Brush Cover	(1)
125	06-82-5346	8-32 x 3/4" Pan Hd. Taptite T-20	(2)
127	42-28-0025	Rear Guide Roller Kit	(1)
128	14-30-0015	Gearcase Top Assembly	(1)
136	14-46-0465	Guide Roller Kit	(1)
137	44-60-0295	Tire Clearing Brush Kit	(1)
140	14-30-0055	Gearcase Cover Kit	(1)

AS AN AID TO REASSEMBLY, TAKE NOTICE OF WIRE ROUTING AND POSITION IN WIRE GUIDES AND TRAPS WHILE DISMANTLING TOOL.

BE CAREFUL AND AVOID PINCHING WIRES BETWEEN HANDLE HALVES WHEN ASSEMBLING.

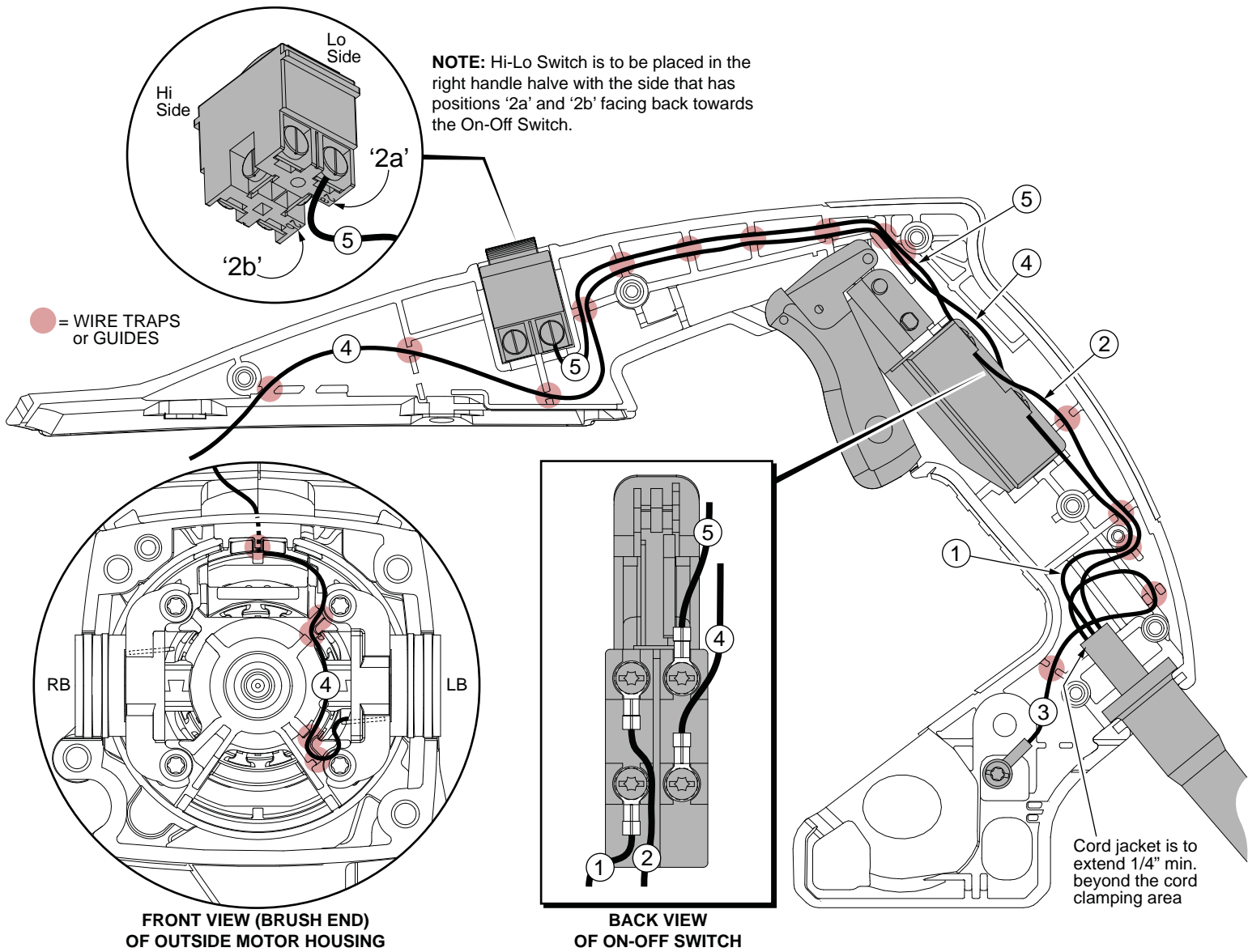

WIRING SPECIFICATIONS

Wire No.	Wire Color	Origin or Gauge	Length	Terminals, Connectors and 1 or 2 End Wire Preparation
1	Black	Cord	-----	Component of the cord set. Connect to lower left position of the on-off switch.
2	White	Cord	-----	Component of the cord set. Connect to upper left position of the on-off switch.
3	Green	Cord	-----	Component of the cord set. Connect to grounding area on surface of the gearcase.
4	Black	23-94-0525	-----	Leadwire assembly. Connect ring terminal to the lower right position of the on-off switch. Route wire assembly through handle and into the motor housing. Connect to left brush holder.
5	White	23-94-0445	-----	Leadwire assembly. Connect ring terminal (without shrink tubing) to the upper right position of the on-off switch. Connect ring terminal with shrink tubing to hi-low switch with white wire #10.

AS AN AID TO REASSEMBLY, TAKE NOTICE OF WIRE ROUTING AND POSITION IN WIRE GUIDES AND TRAPS WHILE DISMANTLING TOOL.

BE CAREFUL AND AVOID PINCHING WIRES BETWEEN HANDLE HALVES WHEN ASSEMBLING.

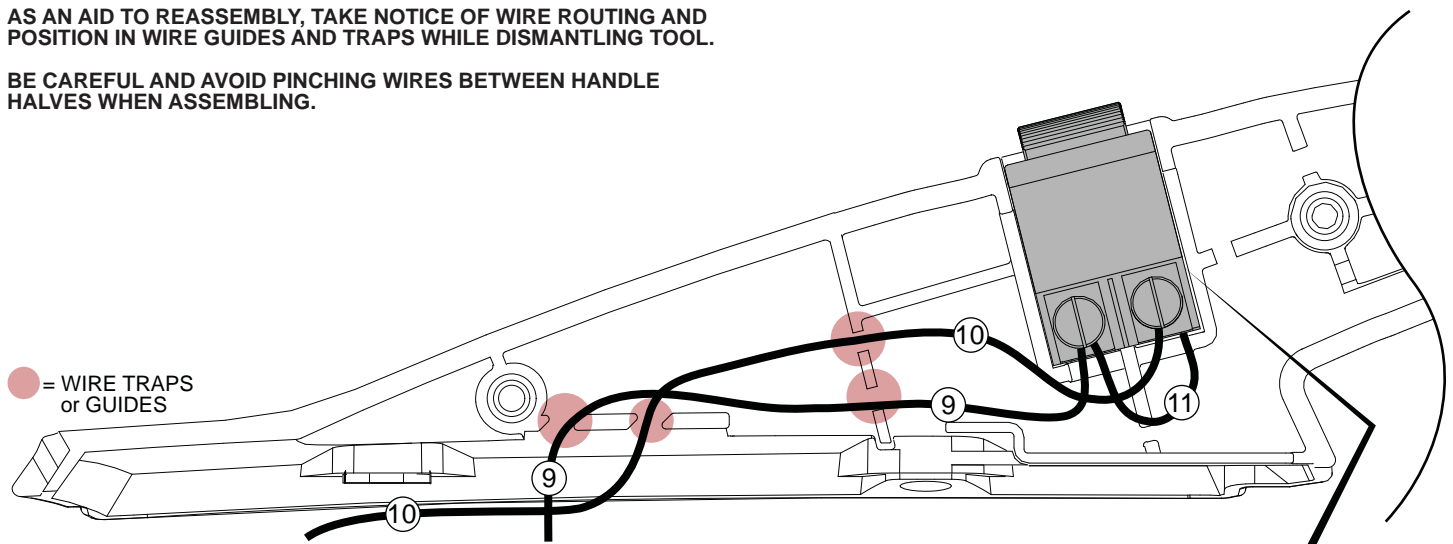

● = WIRE TRAPS or GUIDES

NOTE: Hi-Lo Switch is to be placed in the right handle half with the side that has positions '2a' and '2b' facing back towards the On-Off Switch.

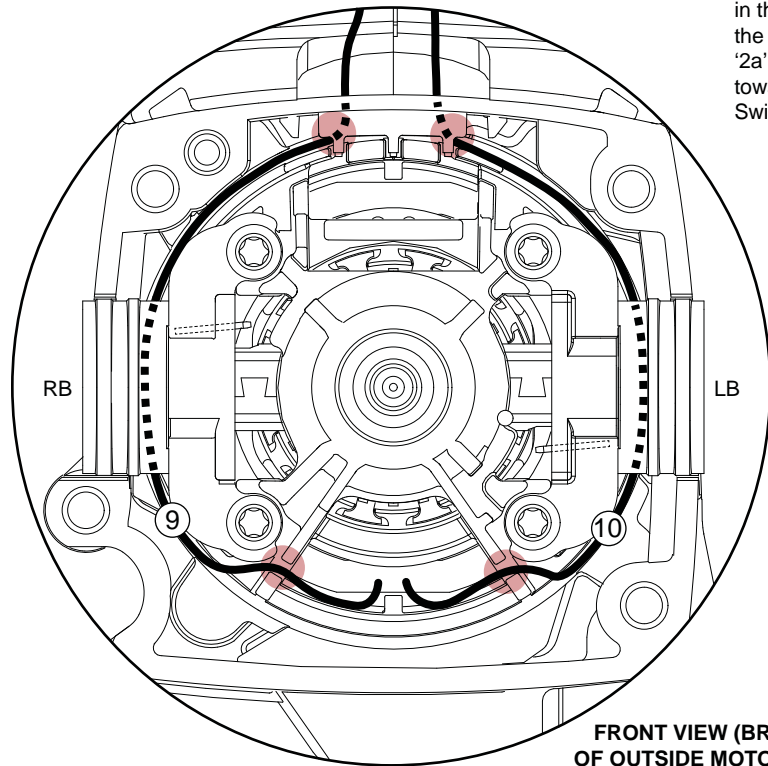

FRONT VIEW (BRUSH END) OF OUTSIDE MOTOR HOUSING

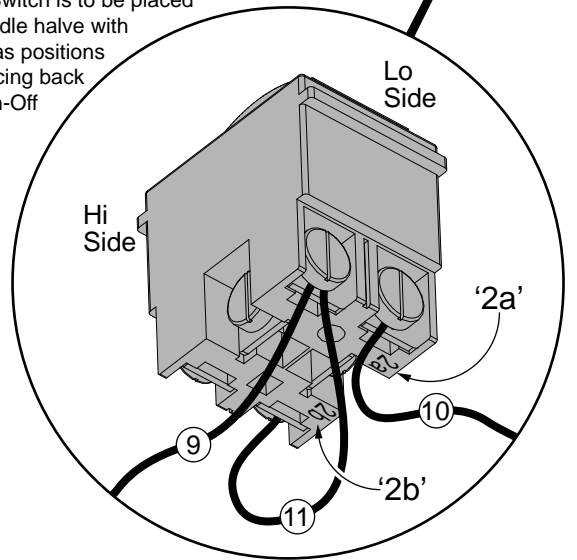

HI-LO SWITCH WIRING DETAIL

WIRING SPECIFICATIONS

Wire No.	Wire Color	Origin or Gauge	Length	Terminals, Connectors and 1 or 2 End Wire Preparation
9	Black	18-07-0045	-----	Component of the field. Connect ring terminal to hi-low switch as shown along with one end of white jumper wire #11.
10	White	18-07-0045	-----	Component of the field. Connect ring terminal to hi-low switch as shown along with ring terminal of white wire #5.
11	White	23-94-0505	-----	Jumper wire. Connect to hi-low switch as shown.

AS AN AID TO REASSEMBLY, TAKE NOTICE OF WIRE ROUTING AND POSITION IN WIRE GUIDES AND TRAPS WHILE DISMANTLING TOOL.

BE CAREFUL AND AVOID PINCHING WIRES BETWEEN HANDLE HALVES WHEN ASSEMBLING.

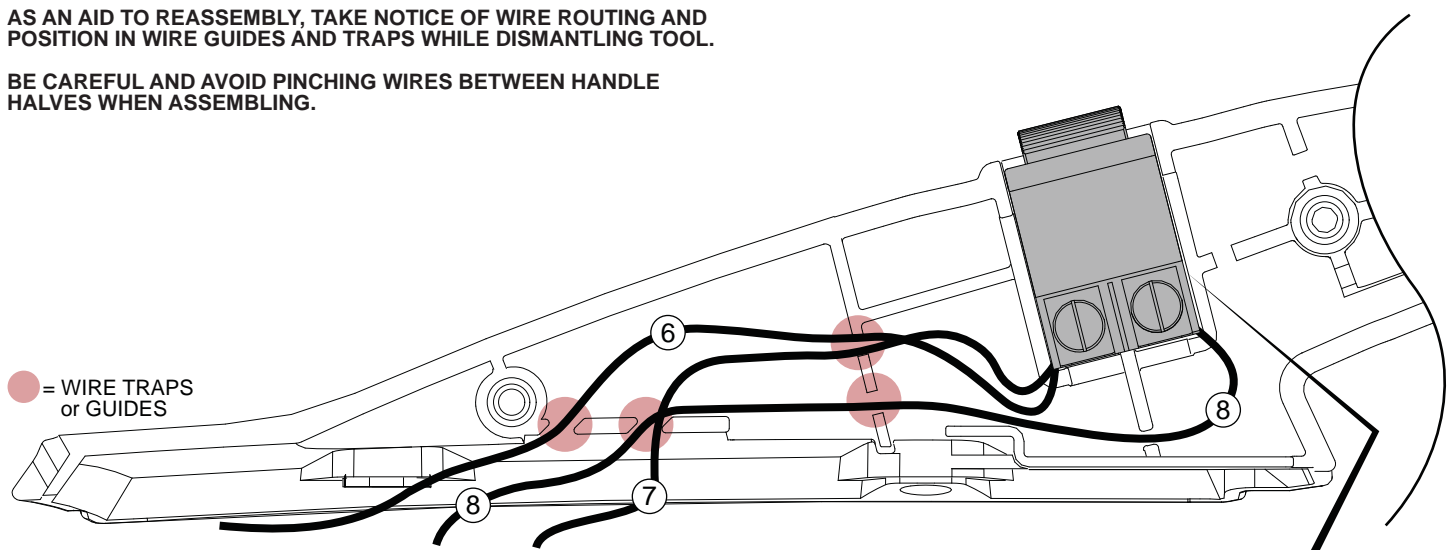

● = WIRE TRAPS or GUIDES

NOTE: Hi-Lo Switch is to be placed in the right handle half with the side that has positions '2a' and '2b' facing back towards the On-Off Switch.

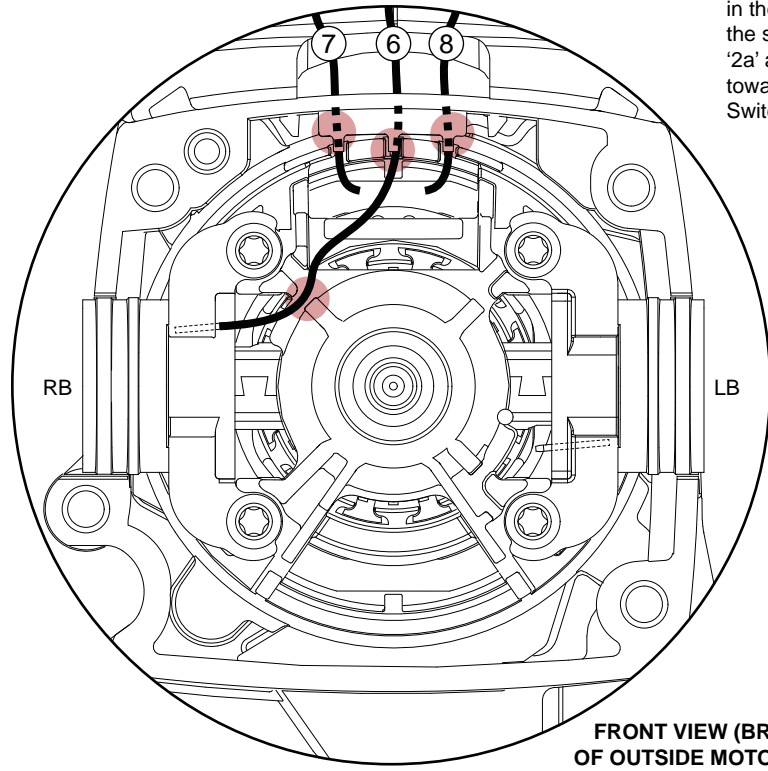

FRONT VIEW (BRUSH END) OF OUTSIDE MOTOR HOUSING

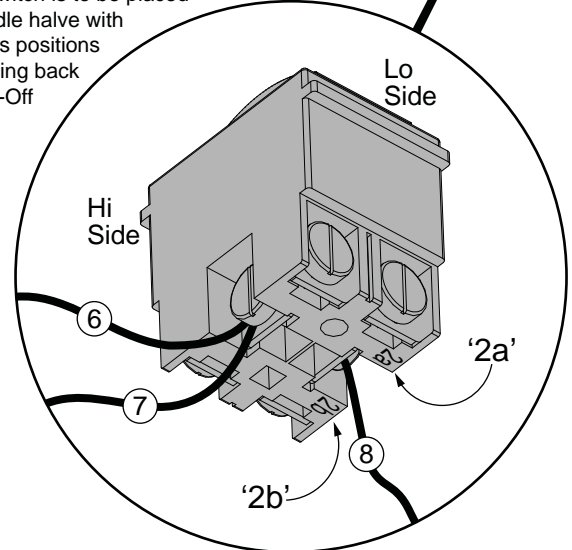

HI-LO SWITCH WIRING DETAIL

WIRING SPECIFICATIONS

Wire No.	Wire Color	Origin or Gauge	Length	Terminals, Connectors and 1 or 2 End Wire Preparation
6	White	23-94-0515	-----	Leadwire assembly. Connect ring terminal end to hi-low switch along with ring terminal of blue field wire #7. Connect other end to the right brush holder.
7	Blue	18-07-0045	-----	Component of the field. Connect ring terminal to hi-low switch along with white wire #6.
8	Red	18-07-0045	-----	Component of the field. Connect ring terminal to hi-low switch as shown.