



SERVICE PARTS LIST

**BULLETIN NO.
54-40-6202**

SPECIFY CATALOG NO. AND SERIAL NO. WHEN ORDERING PARTS		REVISED BULLETIN 54-40-6201	DATE Jan. 2014
AC COMPACT BAND SAW			
CATALOG NO.	6242-6	STARTING SERIAL NO.	C13C
			WIRING INSTRUCTION 58-01-6200

EXAMPLE:
00 0 Component Parts (Small #)
Are Included When Ordering
The Assembly (Large #).

FIG.	PART NO.	DESCRIPTION OF PART	NO. REQ.
35	06-82-5574	10-24 x 7/8" Pan Hd. Tapt. T-25 Screw	(7)
36	06-82-0035	M5 Pan Hd. T-20 Screw	(3)
39	-----	Deck	(1)
47	23-44-0025	Brush Cap	(2)
48	22-20-0070	Brush Tube Assembly	(2)

49	22-18-0020	Carbon Brush Assembly	(2)
50	18-07-2000	Service Field	(1)
51	14-20-0175	LED with Box Assembly	(1)
52	16-07-2000	Service Armature	(1)
53	05-78-0305	Switch Screw	(4)
55	06-82-5320	8-32 x 5/8" Pan Hd. Slit. Tapt. T-20 Screw	(3)
56	28-28-0080	Diaphragm	(1)
57	02-04-0645	Ball Bearing	(1)
58	-----	1st Gear	(1)
59	-----	Ball Bearing	(1)
60	-----	2nd Bevel Pinion	(1)
61	-----	Bevel/Spur Gear	(1)
62	-----	Needle Bearing	(2)
63	-----	Gearcase	(1)
64	02-04-0135	Ball Bearing	(1)
65	22-64-0485	Cord	(1)
66	45-30-0025	Rubber Slug	(4)
67	-----	3rd Gear	(1)
68	-----	Pulley Shaft	(1)
69	43-96-0105	Key	(1)
70	02-04-1525	Ball Bearing	(1)
71	45-88-0406	Washer	(1)
72	28-14-0180	Bearing Plate Bottom	(1)
73	44-76-0210	Cord Protector	(1)
74	06-82-7270	8-16 x 5/8" Pan Hd. Slit. Plast. T-20 Screw	(14)
75	-----	Handle - Left	(1)
76	02-04-0175	Ball Bearing	(1)
77	22-56-0475	Terminal Block	(1)
78	42-55-0110	Carrying Case	(1)
79	06-82-5294	1/4-20 x 3/4" Pan Hd. Tapt. T-30 Screw	(2)
80	23-66-0395	Switch	(1)
81	06-82-7251	8-16 x 3/8" Pan Hd. Slit. Plast. T-20 Screw	(1)
82	06-82-8828	8-32 x 5/16" Pan Hd. Tapt. T-20 Screw	(1)
83	05-90-0225	Washer	(1)
84	23-66-1045	LED Switch	(1)
85	42-38-0085	Soft Cover	(1)
86	-----	Handle - Right	(1)
87	06-82-0045	3/8"-16 UNC-3A Hex Recess Screw	(1)
88	31-44-0095	Front T-Handle	(1)
89	06-82-5316	8-32 x 1/2" Pan Hd. Slit. Tapt. T-20 Screw	(2)
90	45-88-0825	Washer	(2)
91	-----	Motor Cover	(1)
94	31-44-0285	Handle Kit	(1)
95	31-15-0195	Motor Cover Assembly	(1)
96	28-90-0010	Deck Assembly	(1)
99	14-20-0145	Main PCBA	(1)
105	●	Bevel Pinion Assembly } ORDER AS A SET (1)	
106	●	Bevel/Spur Gear Assy. } Cat. No. 32-05-6242 (1)	
107	14-73-0040	Pulley Gear Assembly	(1)
108	14-30-0050	Top Gearcase Assembly	(1)
109	14-20-0155	LED Driver PCBA	(1)
110	14-20-0165	Sensor PCBA	(1)
111	34-40-0205	O-Ring	(1)
112	02-04-0170	Ball Bearing	(1)
	23-94-0060	Black Leadwire Assy. - To #77 & #80 (Not Shown)	(1)
	23-94-0065	White Leadwire Assy. - To #77 & #80 (Not Shown)	(1)
	23-94-0080	Red Leadwire Assy. - To #84 & #80 (Not Shown)	(1)
	23-94-0085	Red Leadwire Assy. - To #48 (Top Brush) & connector on #99 (Not Shown)	(1)

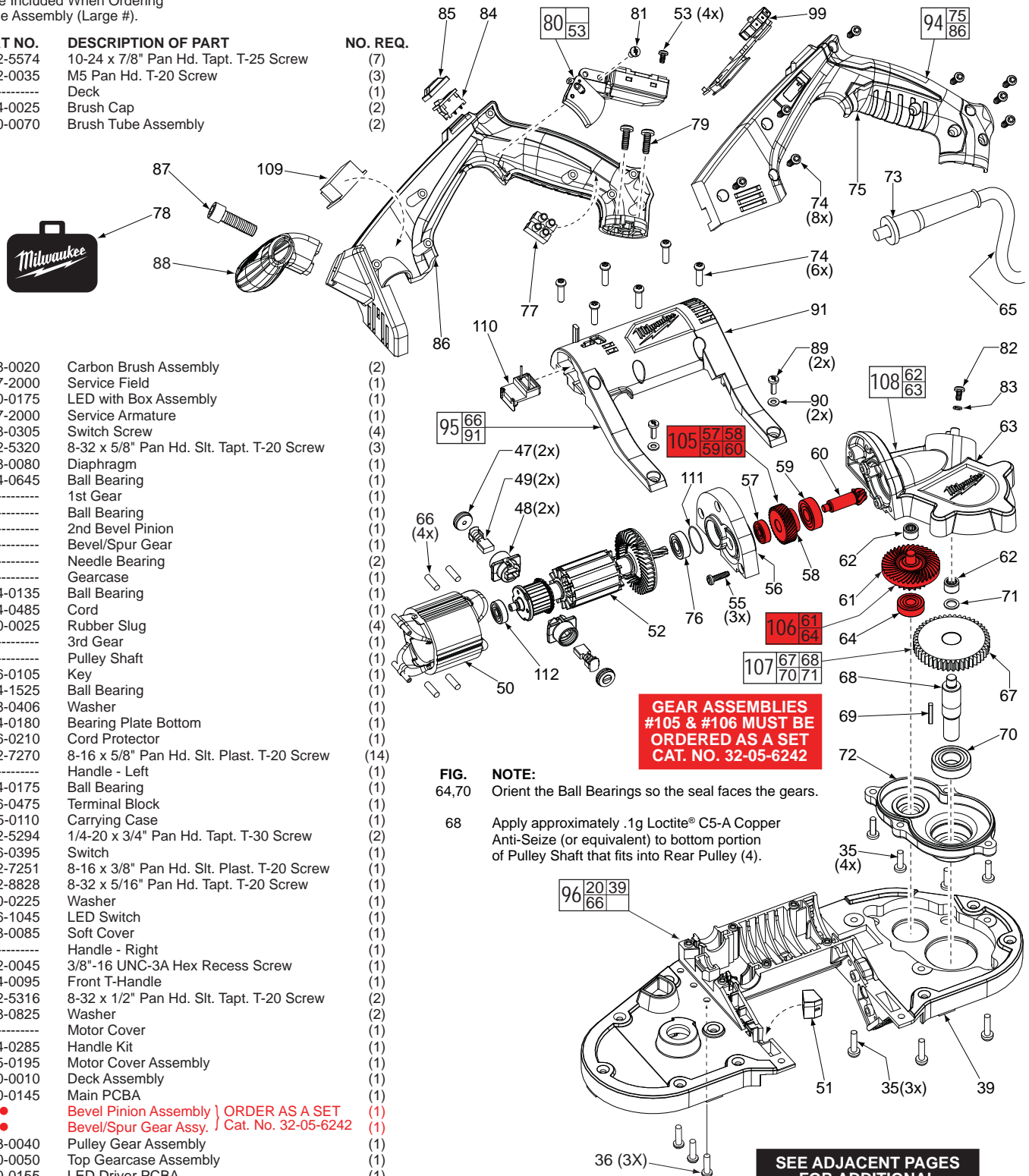

FIG. NOTE:
64,70 Orient the Ball Bearings so the seal faces the gears.

68 Apply approximately .1g Loctite® C5-A Copper Anti-Seize (or equivalent) to bottom portion of Pulley Shaft that fits into Rear Pulley (4).

**SEE ADJACENT PAGES
FOR ADDITIONAL
SERVICE NOTES AND
LUBRICATION**

**SEE SERVICE WIRING
DIAGRAM 58-01-6200**

MILWAUKEE ELECTRIC TOOL CORPORATION
13135 W. LISBON RD., BROOKFIELD, WI 53005

★ = Part number change from previous service parts list.

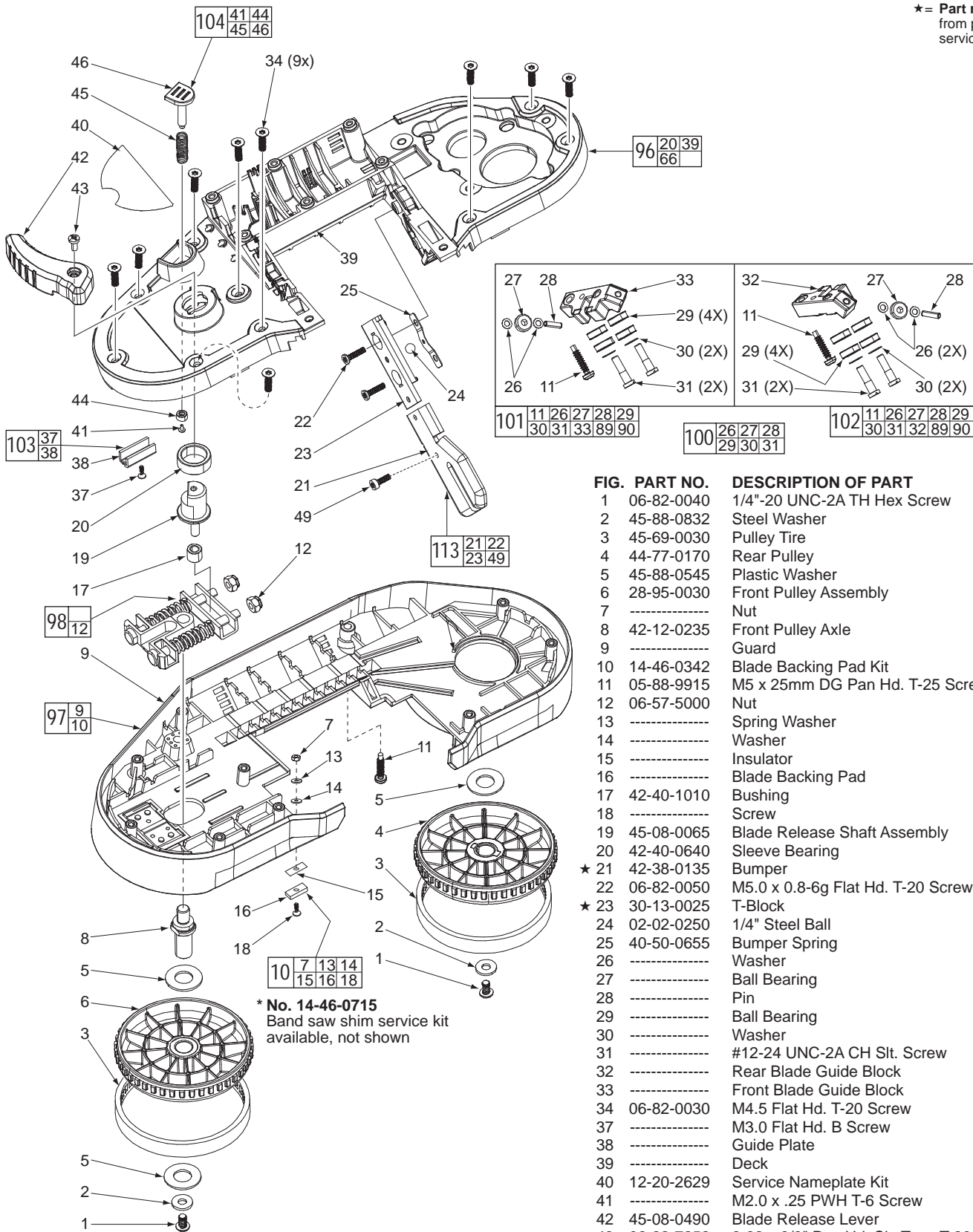
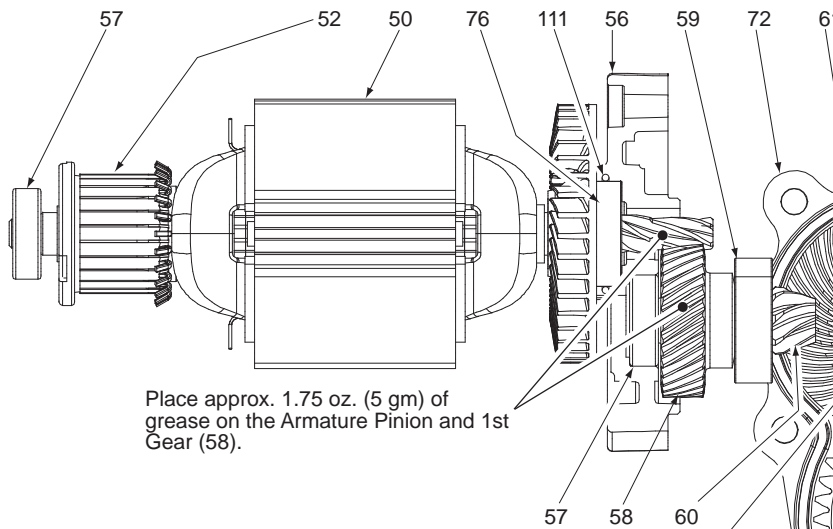

FIG.	PART NO.	DESCRIPTION OF PART	NO. REQ.
1	06-82-0040	1/4"-20 UNC-2A TH Hex Screw	(2)
2	45-88-0832	Steel Washer	(2)
3	45-69-0030	Pulley Tire	(2)
4	44-77-0170	Rear Pulley	(1)
5	45-88-0545	Plastic Washer	(3)
6	28-95-0030	Front Pulley Assembly	(1)
7	-----	Nut	(1)
8	42-12-0235	Front Pulley Axle	(1)
9	-----	Guard	(1)
10	14-46-0342	Blade Backing Pad Kit	(1)
11	05-88-9915	M5 x 25mm DG Pan Hd. T-25 Screw	(3)
12	06-57-5000	Nut	(2)
13	-----	Spring Washer	(1)
14	-----	Washer	(1)
15	-----	Insulator	(1)
16	-----	Blade Backing Pad	(1)
17	42-40-1010	Bushing	(1)
18	-----	Screw	(1)
19	45-08-0065	Blade Release Shaft Assembly	(1)
20	42-40-0640	Sleeve Bearing	(1)
★ 21	42-38-0135	Bumper	(1)
22	06-82-0050	M5.0 x 0.8-6g Flat Hd. T-20 Screw	(2)
★ 23	30-13-0025	T-Block	(1)
24	02-02-0250	1/4" Steel Ball	(1)
25	40-50-0655	Bumper Spring	(1)
26	-----	Washer	(4)
27	-----	Ball Bearing	(2)
28	-----	Pin	(2)
29	-----	Ball Bearing	(8)
30	-----	Washer	(4)
31	-----	#12-24 UNC-2A CH Slit. Screw	(4)
32	-----	Rear Blade Guide Block	(1)
33	-----	Front Blade Guide Block	(1)
34	06-82-0030	M4.5 Flat Hd. T-20 Screw	(9)
37	-----	M3.0 Flat Hd. B Screw	(1)
38	-----	Guide Plate	(1)
39	-----	Deck	(1)
40	12-20-2629	Service Nameplate Kit	(1)
41	-----	M2.0 x .25 PWH T-6 Screw	(1)
42	45-08-0490	Blade Release Lever	(1)
43	06-82-7252	8-32 x 3/8" Pan Hd. Slit. Tapt. T-20 Screw	(1)
44	-----	Bushing	(1)
45	-----	Spring	(1)
46	-----	Blade Ejection Pin	(1)
★ 49	14-74-0275	Bandsaw Fixed Material Guide w/ Screw	(1)
96	28-90-0010	Deck Assembly	(1)
97	28-41-0052	Guard Assembly	(1)
98	42-18-0025	Blade Tension Bar Assembly	(1)
100	14-46-0465	Guide Block Hardware Kit	(1)
101	42-28-0410	Front Guide Block Assembly	(1)
102	42-28-0420	Rear Guide Block Assembly	(1)
103	44-66-0325	Guide Plate Kit	(1)
104	44-60-0240	Blade Ejection Shaft Kit	(1)
★ 113	42-38-0010	Bumper Assembly	(1)

- FIG. NOTE:**
- 24 Apply Loctite® Silver Grade Anti-Seize Stick 80209 (or equivalent) to Steel Ball.
 - 8 Apply Loctite® Cleaner 755 (or equivalent) to Front Pulley Axle thread first then place a drop or two of Blue Loctite® 443 (or equivalent) to axle threads.
 - 18,41 Apply a drop of Blue Loctite® 443 (or equivalent) to threads of each screw.
 - 9,38 Apply Loctite® C5-A Copper Anti-Seize (or equivalent) to metal insert in Guard and to Guide Plate. Approximately .1g for each part.



LUBRICATION:
Use Type 'J' Grease, No. 49-08-4220

Place approx. 1.75 oz. (5 gm) of grease on the 2nd Bevel Pinion (60) and Bevel Spur Gear (61).

Place approx. 1.75 oz. (5 gm) of grease on and around the 3rd Gear.

Place approx. 1.75 oz. (5 gm) of grease on the Armature Pinion and 1st Gear (58).

SCREW TORQUE CHART				
ITEM	PART NO.	PART DESCRIPTION	SEAT TORQUE	
			(IN/LBS)	(KG/CM)
1	06-82-0040	1/4"-20 UCN-2A TH Hex	65-74	75-85
7	-----	M2 x 0.4 Nut	2-4	3-5
8	42-12-0235	Front Pulley Axle	78-87	90-100
11	05-88-9915	M5 x 25mm DG PH T-25	16-21	19-24
12	06-57-5000	Flex-Loc Nut	To Assembly Length	
18	-----	M2 x 0.4 T-6	2-4	3-5
22	06-82-0050	M5 x .8-6g FH T-20	26-30	30-35
31	06-82-0120	#12-24 UNC-2A CH Slotted	39-48	45-55
34	06-82-0030	M4.5 FH T-20	16-21	19-24
35	06-82-5574	#10-24 x 7/8" PH T-25	39-48	45-55
36	06-82-0035	M5.0 PH T-20	22-26	25-30
37	06-82-0010	M3 FH B	6-9	7-10
41	06-82-0025	M2.0 x .25 PWH T-6	2-4	3-5
43	06-82-7252	#8-32 x 3/8" PH T-20	22-26	25-30
55	06-82-5320	#8-32 x 5/8" PH T-20	26-31	30-36
74	06-82-7270	#8-16 x 5/8" PH T-20	16-21	19-24
79	06-82-5294	1/4"-20 UNC-2A PH T-30	65-74	75-85
81	06-82-7251	#8-16 x 3/8" PH T-20	10-14	12-16
82	06-82-8828	T-20 Ground Screw	9-13	10-15
87	06-82-0045	3/8"-16 UNC-3A T-20	87-104	100-120
89	06-82-5316	#8-32 x 1/2" PH T-20	16-21	19-24

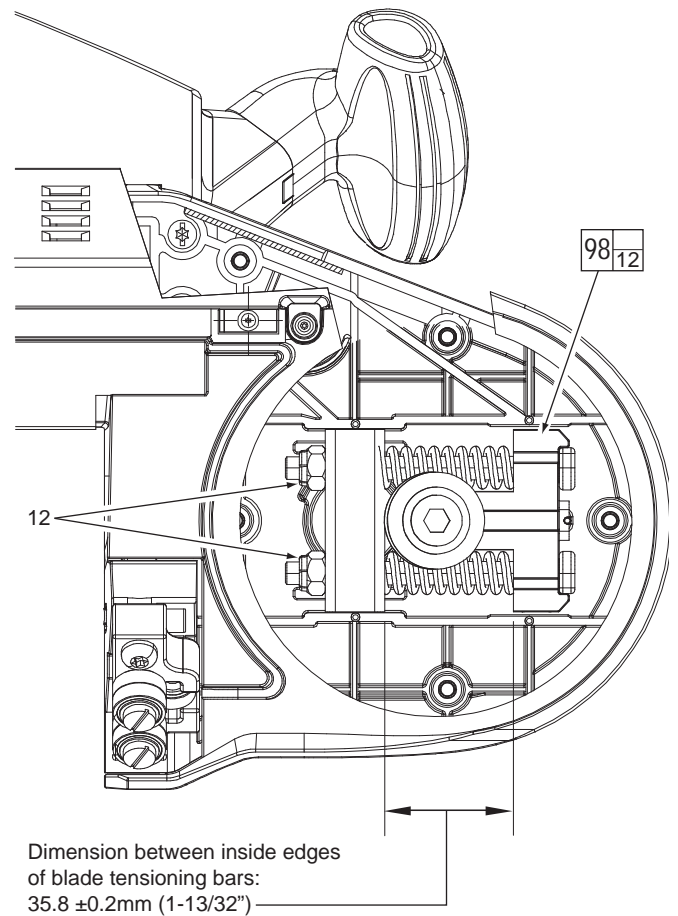

Dimension between inside edges of blade tensioning bars: 35.8 ± 0.2mm (1-13/32")