



SERVICE PARTS LIST

**BULLETIN NO.
55-40-0332**

SPECIFY CATALOG NO. AND SERIAL NO. WHEN ORDERING PARTS		REVISED BULLETIN	DATE
D.I. VARIABLE SPEED JIG SAW		55-40-0331	Feb. '95
CATALOG NO. 6256-2	STARTING SERIAL NO. 749A	WIRING INSTRUCTION 58-01-0093	

EXAMPLE:
Component Parts (Small #) Are Included
When Ordering The Assembly (Large #).

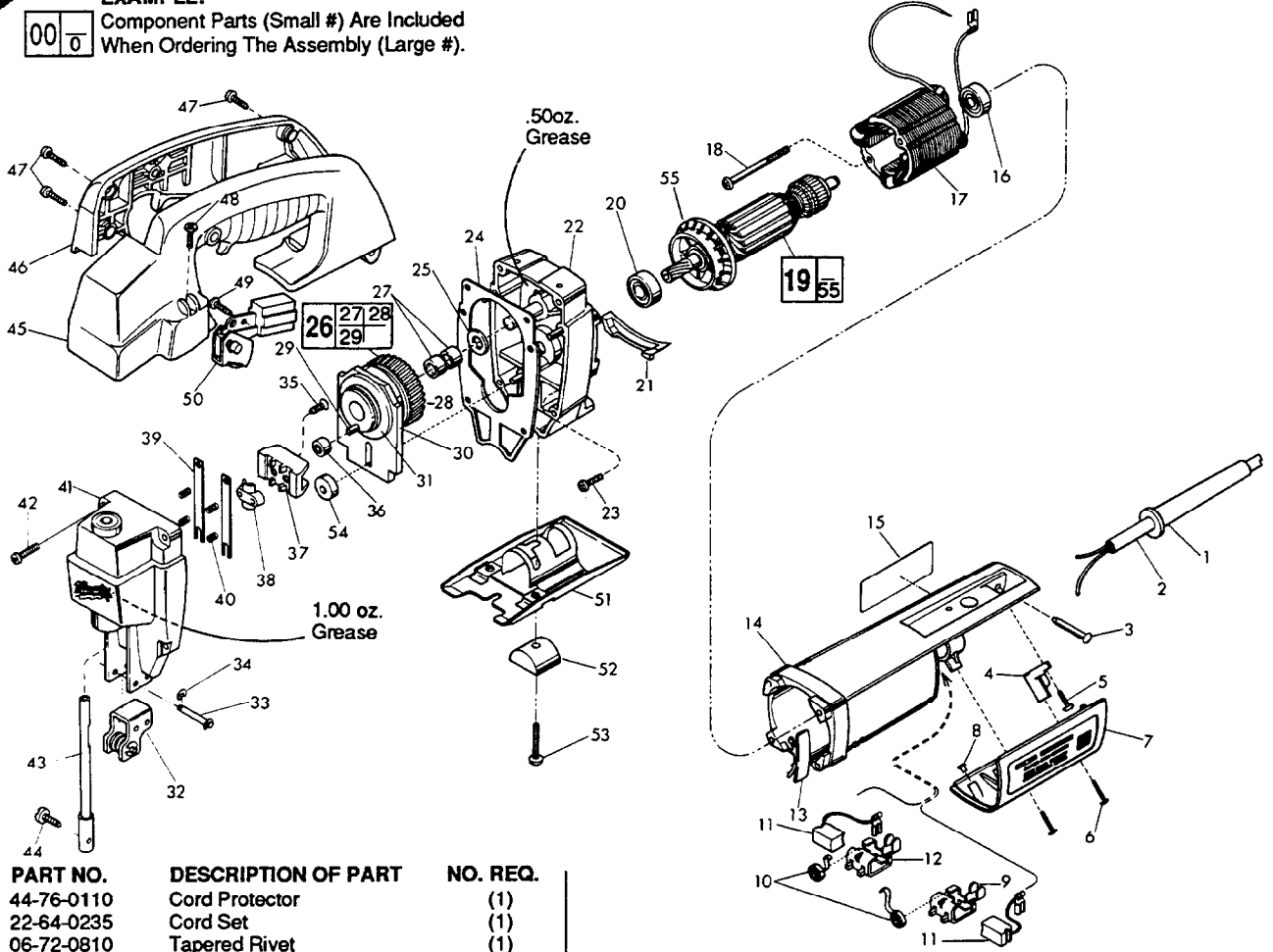

FIG.	PART NO.	DESCRIPTION OF PART	NO. REQ.
1	44-76-0110	Cord Protector	(1)
2	22-64-0235	Cord Set	(1)
3	06-72-0810	Tapered Rivet	(1)
4	31-17-0120	Cord Clamp	(1)
5	06-82-7270	8-16 x 5/8" Plastite T-20 Screw	(2)
6	06-82-7270	8-16 x 5/8" Plastite T-20 Screw	(2)
★ 7	31-15-0290	Cover	(1)
8	42-38-0181	Rubber Bumper	(2)
9	22-20-0691	L. H. Brush Holder	(1)
10	23-52-0240	Brush Spring	(2)
11	22-18-0750	Carbon Brush Assembly	(2)
12	22-20-0692	R. H. Brush Holder	(1)
13	31-15-0300	Vent Cover	(1)
14	31-50-0310	Motor Housing	(1)
★ 15	12-20-0520	Service Nameplate Kit	(1)
16	02-04-0850	Ball Bearing	(1)
17	18-06-0041	240 V. Field	(1)
18	06-82-7410	8-16 x 1-7/8" Plastite T-20 Screw	(2)
19	16-06-0036	240 V. Armature	(1)
★ 20	02-04-0849	Ball Bearing	(1)
21	31-05-0161	Air Deflector	(1)
22	14-30-0411	Gear Case Assembly	(1)
23	06-82-7270	8-16 x 5/8" Plastite T-20 Screw	(4)
24	43-44-0701	Gasket	(1)
25	45-88-0480	Bronze Washer	(1)
26	32-30-0011	Drive Gear Assembly	(1)
27	02-50-2423	Roller Bearing	(2)
28	32-30-0010	Drive Gear	(1)
29	06-65-1572	Pin	(1)
30	42-87-0071	Counter Balance	(1)
31	44-86-0335	Counter Balance Retainer	(1)
32	42-36-1640	Roller Bracket Assembly	(1)
33	06-65-0870	Bracket Pin	(2)
34	34-60-0300	Retaining Ring	(4)
35	06-82-0970	8-32 x 3/8" Flat Hd. T-15 Screw	(2)

FIG.	PART NO.	DESCRIPTION OF PART	NO. REQ.
36	44-96-0080	Roller Assembly	(1)
37	45-98-0181	Yoke	(1)
38	42-68-0451	Yoke Clamp	(1)
39	44-81-0010	Rail	(2)
40	40-50-8015	Coil Spring	(4)
41	14-38-0460	Front Housing Assembly	(1)
42	06-82-5346	8-32 x 3/4" Taptite T-20 Screw	(4)
43	38-50-5760	Spindle Assembly	(1)
44	45-04-0566	Blade Clamp Screw	(1)
45	31-44-1430	Handle Half-Left	(1)
46	31-44-1435	Handle Half-Right	(1)
★ 47	06-82-7284	8-16 x 3/4" Plastite T-20 Screw	(4)
48	06-82-5316	8-32 x 1/2" Taptite T-20 Screw	(2)
49	06-82-7409	8-16 x 1/2" Plastite T-20 Screw	(1)
50	23-66-2040	Switch with Lock Button	(1)
51	45-16-0510	Swivel Shoe Assembly	(1)
52	44-86-0440	Shoe Retainer	(1)
53	06-81-0507	1/4-20 x 3/4" Slit. Pan Hd. Screw	(1)
54	45-36-1370	Spacer	(1)
55	22-84-0680	Fan	(1)

FIG. LUBRICATION
22 .50 Oz. Type "F" Grease, No. 49-08-4160.
41 1.00 Oz. Type "F" Grease, No. 49-08-4160.

FIG. NOTES
35 Torque To 28-32 In./Lbs.

MILWAUKEE ELECTRIC TOOL CORPORATION
13135 W. LISBON RD., BROOKFIELD, WI 53005