



SERVICE PARTS LIST

BULLETIN NO.
55-40-0376

SPECIFY CATALOG NO. AND SERIAL NO. WHEN ORDERING PARTS		REVISED BULLETIN 55-40-0375	DATE Nov. '98
ORBITAL JIG SAW			
CATALOG NO. 6266-51	STARTING SERIAL NO. 857B	WIRING INSTRUCTION 58-03-0335	

00
0

EXAMPLE:
Component Parts
(Small #) Are Included
When Ordering The
Assembly (Large #).

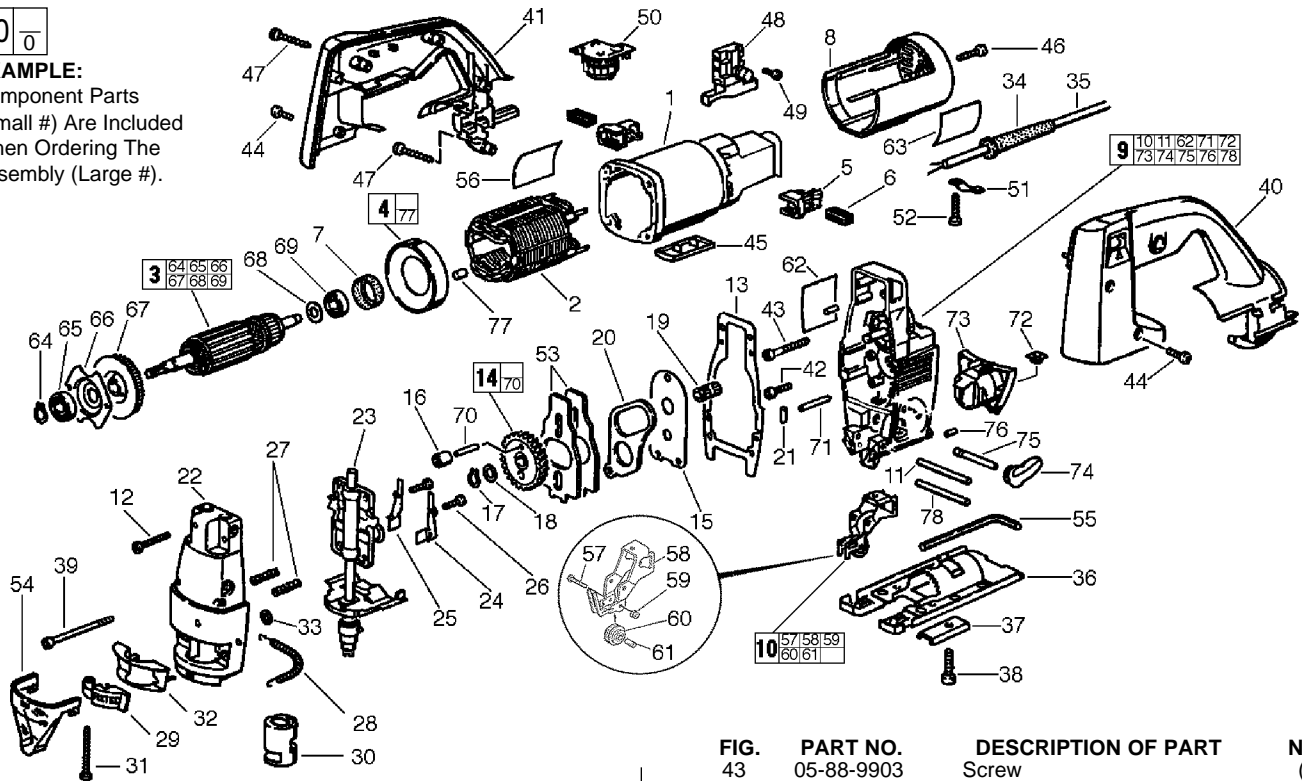

FIG.	PART NO.	DESCRIPTION OF PART	NO. REQ.
1	31-50-1230	Motor Housing	(1)
2	18-06-0110	230 Volt Field	(1)
3	16-06-0110	230 Volt Armature Assembly	(1)
4	31-05-0200	Air Deflector Plate	(1)
5	22-20-0870	Brush Holder	(2)
6	22-18-0861	Carbon Brush	(2)
7	45-22-0540	Rubber Sleeve	(1)
8	31-15-0480	Cover	(1)
9	14-30-0790	Gear Case Complete	(1)
10	42-36-1785	Support Bracket Complete	(1)
11	06-65-3735	Support Bracket Pin	(1)
12	05-88-9750	Screw	(2)
★ 13	43-44-1070	Gasket	(1)
14	32-30-0131	Gear Assembly	(1)
15	44-66-6165	Spacer Plate	(1)
16	02-50-9996	Needle Bearing	(1)
17	34-60-3670	Ring	(1)
18	45-88-8600	Washer	(1)
19	02-50-9990	Needle Bearing	(1)
20	42-09-0140	Rocker Arm	(1)
21	44-60-1420	Linkage Pin	(1)
22	14-38-0670	Gear Case Cover	(1)
23	38-50-6050	Spindle Assembly	(1)
24	42-68-1020	Left Clamp	(1)
25	42-68-1010	Right Clamp	(1)
26	05-88-9751	Screw	(2)
27	40-50-8790	Pressure Spring	(2)
28	40-50-8800	Tension Spring	(1)
29	44-10-0350	Blade Clamp Lever	(1)
30	45-22-0530	Index Sleeve	(1)
31	05-88-9752	Screw	(1)
32	45-03-0160	Screen	(1)
33	44-90-4390	Ring	(1)
34	44-76-0270	Cord Protector	(1)
35	22-64-0892	Cord	(1)
36	45-16-0630	Shoe	(1)
37	44-86-0580	Thrust Piece	(1)
38	05-74-0675	Screw	(1)
39	05-88-9901	Screw	(2)
40	31-44-1920	Left Handle Half	(1)
41	31-44-1930	Right Handle Half	(1)
42	05-88-9902	Screw	(2)

FIG.	PART NO.	DESCRIPTION OF PART	NO. REQ.
43	05-88-9903	Screw	(2)
44	05-88-9753	Screw	(4)
45	31-15-0490	Housing Cap	(1)
46	05-81-0925	Screw	(1)
47	05-88-9601	Screw	(4)
48	23-66-1010	Switch (Terminal Screws Not Included)	(1)
49	05-81-0932	Screw	(2)
50	14-20-0791	Speed Dial Assembly	(1)
51	31-17-0240	Cord Clamp	(1)
52	05-81-0930	Screw	(2)
53	42-87-0120	Counter Balance	(2)
54	45-12-0530	Front Shield	(1)
55	45-96-0075	Hex Key	(1)
56	12-25-1161	Nameplate	(1)
57	05-81-0935	Screw	(1)
58	42-36-1800	Support Bracket	(1)
59	05-55-0035	Nut	(1)
60	44-96-0175	Support Roller	(1)
61	42-40-1025	Bushing	(1)
62	10-15-9502	Instruction Label	(1)
63	10-15-9505	Logo Label	(1)
64	44-90-4405	Retaining Ring	(1)
65	02-04-1805	Ball Bearing	(1)
66	44-86-0205	Bearing Retainer	(1)
67	22-84-0930	Fan	(1)
68	45-88-1220	Washer	(1)
69	02-04-1800	Ball Bearing	(1)
70	44-60-1506	Pin	(1)
71	44-60-1510	Pin	(1)
72	05-55-0055	Nut	(1)
73	45-22-0060	Dust Sleeve	(1)
74	30-58-0060	Orbit Lever	(1)
75	36-10-0830	Cam Shaft	(1)
76	44-60-1500	Pin	(1)
77	45-30-0055	Slug	(2)
78	06-65-0560	Pin	(1)
	22-33-0440	Suppressor (Not Shown)	(1)

FIG. LUBRICATION
9 3/4 oz. type "L" grease, No. 49-08-4170.

MILWAUKEE ELECTRIC TOOL CORPORATION
13135 W. LISBON RD., BROOKFIELD, WI 53005

6266-51 Orbital Jigsaw Service Instructions - Hints

Following are hints for disassembling and assembling the 6266-51 Orbital Jigsaw. Note that they are not complete service instructions.

Screen (#32) removal: Use a screwdriver to gently snap screen off of tool. Rotate Quik-Lok Blade Clamp Lever (#29) and remove screen.

Quik-Lok Blade Clamp Lever (#29) removal: After Tension Spring (#28) is removed, remove screw (#31) from bottom of Blade Clamp Lever. Rotate Blade Clamp Lever approximately 15 to 20 degrees and hold the Index Sleeve (#30) in this position. Press end of Blade Clamp Lever so it pivots out of the Index Sleeve.

Index Sleeve (#30) removal: Extend spindle to its outward position. Depress spindle and pull off Index Sleeve. Be sure to extend spindle when assembling.

Spindle Assembly (#23) removal: Extend spindle to its outward position. After the left and right clamps (#24, #25) and screws (#26) are removed, remove the springs (#27). Pull Spindle Assembly out, making sure spindle nut fits through hole in the Gear Case Cover (#22). Be sure to extend spindle when assembling.

Lubrication: Use 0.5 oz. grease in Gear and Gear area. After all parts are clean of used grease, apply new grease as follows: Lightly (yet completely) grease the Counterbalance Guide Pin, Gear pin, and orbit pivot (all of which are inside the Gear Case). Lightly grease the 2 Needle Bearings (#16, #19), Spacer Plate (#15), Rocker arm (#20), 2 Counter Balances (#53), armature shaft pinion, linkage pin (#21), and Gear (#14) before their installations. Note: the Linkage Pin must be installed before the Rocker Arm. After installation of the Gear, apply the remainder of the 0.5 oz. grease to Gear and Gear area. Apply grease favoring the top of the tool, as grease will settle toward the bottom as the tool is used.

Use 0.25 oz. grease in the Spindle and Spindle Yoke areas. Before installation of the Spindle Assembly (#23) into the Gear Case Cover (#22), lightly grease the pivots in the Gear Case Cover (for the orbital movement), the Pressure Springs (#27), the left and right Clamps (#24, #25), and the Spindle Assembly (#23) - excluding the Blade Clamp Nut. After installation of these parts into the Gear Case Cover, apply the remainder of the 0.25 oz. grease to Spindle and Spindle Yoke areas.

Assembly of Quik-Lok Blade Clamp Lever (#29): After installing Blade Clamp Tension Spring (#28) on the Gear Case Cover (#22) and inserting Index Sleeve (#30), make sure other end of spring is fed through the hole towards the front of the tool, where it is to be attached to the Blade Clamp Lever (#29). Use needle nose pliers to attach spring to Blade Clamp Lever. Rotate the Index Sleeve approximately 15 to 20 degrees after it contacts the tang on the Blade Clamp Nut. Use a needle nose pliers if necessary. Hold the Index Sleeve in this position by hand. Hook the Blade Clamp Lever on the Index Sleeve and install the Blade Clamp Lever so the screw hole is aligned with the Index Sleeve screw hole. Be sure that Tension Spring is in proper position before tightening screw. Before further assembly, operate the Blade Clamp Lever to ensure the blade clamp operates properly.