



SERVICE PARTS LIST

BULLETIN NO.
55-40-6301

SPECIFY CATALOG NO. AND SERIAL NO. WHEN ORDERING PARTS		REVISED BULLETIN	DATE
CORDLESS CIRCULAR SAW		55-40-6300	May 2006
CATALOG NUMBER	6310-50 (PWS 18)	WIRING INSTRUCTION 58-01-1365	
STARTING SERIAL NO.	057B	★ = Part number change from previous service parts list.	
PRODUCT NUMBER	4000 3935 32		

EXAMPLE: 00 0 Component Parts (Small #) Are Included When Ordering The Assembly (Large #).

Functionally check switch lock-out #40 by attempting to turn on tool by applying a reasonable amount of force, up to 8 lbs., to the switch trigger #21. The tool must not turn on. Release trigger. Actuate the lock-out lever and apply a reasonable amount of force to the switch trigger. The tool must turn on. While the trigger is still in the "ON" position, release the lock-out. Release the trigger. The tool must stop and the lock-out lever must again prevent the actuation of the switch. Repeat the switch check two more times.

NOTE: Switch #21 comes with four screws. Three of the four screws are utilized to secure lead wires. **ALL FOUR SCREWS** must be in place to insure proper brake function! See wiring dia. 58-01-1365.

Apply 3.0 grams of "Y" grease, No. 49-08-5270 to gear bore of gearcase #24. The grease should be directed toward the pinion end of the armature.

Apply a light film of lubricant to the bearing bore of the gearcase before assembling the armature/bearing.

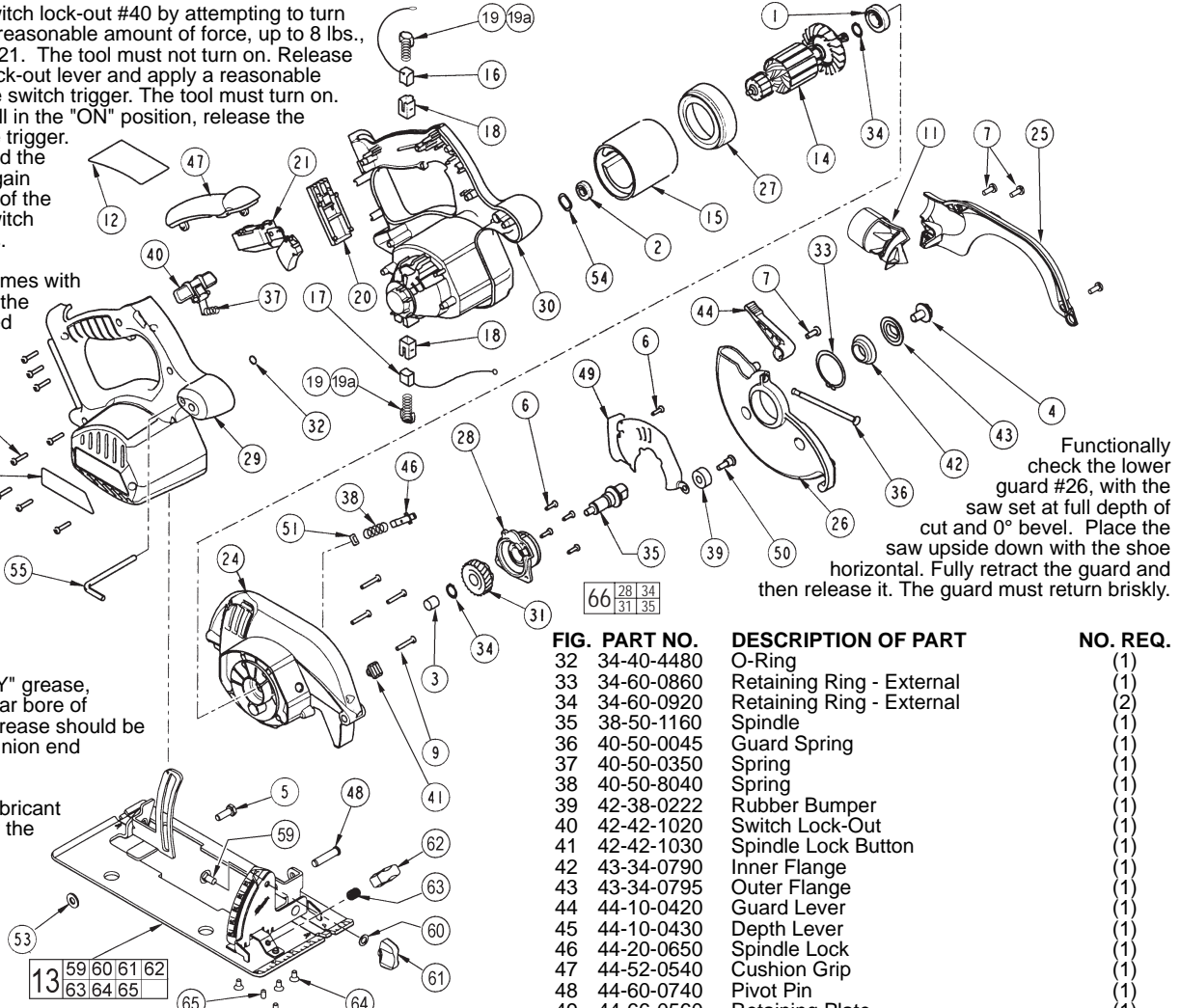

FIG.	PART NO.	DESCRIPTION OF PART	NO. REQ.
1	02-04-1212	Ball Bearing	(1)
2	02-04-5130	Ball Bearing	(1)
3	02-50-1640	Needle Bearing	(1)
4	06-75-1010	Left Hand Screw	(1)
5	06-75-5860	1/4-20 x 3/4 Screw	(1)
6	06-82-5285	6-32 x .5 Pan Hd. Taptite Screw T-15	(5)
7	06-82-5314	10-24 x .5 Pan Hd. Taptite Screw T-25	(5)
8	06-82-7470	Plastite Torx Screw T-15	(8)
9	06-82-7475	Plastite Torx Screw T-15	(4)
10	10-20-6310	Logo Label	(1)
11	31-76-0100	Dust Chute	(1)
12	12-20-1390	Service Nameplate	(1)
13	14-74-0315	Shoe Assembly	(1)
14	16-01-2111	Armature	(1)
15	18-01-2000	Field	(1)
16	22-18-1120	Brush Assembly - Red	(1)
17	22-18-1125	Brush Assembly - Black	(1)
18	22-20-0425	Brush Tube	(2)
19	22-32-0420	Brush Spring Clip	(2)
19a	40-50-8745	Brush Spring	(2)
20	22-56-0230	Connector Block	(1)
21	23-66-1000	Switch	(1)
24	28-14-0746	Gearcase	(1)
25	28-20-1360	Upper Guard Cover	(1)
26	28-41-0955	Lower Guard	(1)
27	31-05-0350	Baffle	(1)
28	31-15-0601	Gearcase Cover	(1)
29	31-44-1970	Right Handle Valve	(1)
30	31-44-1975	Left Handle Valve	(1)
31	32-75-1370	Spindle Gear	(1)

FIG.	PART NO.	DESCRIPTION OF PART	NO. REQ.
32	34-40-4480	O-Ring	(1)
33	34-60-0860	Retaining Ring - External	(1)
34	34-60-0920	Retaining Ring - External	(2)
35	38-50-1160	Spindle	(1)
36	40-50-0045	Guard Spring	(1)
37	40-50-0350	Spring	(1)
38	40-50-8040	Spring	(1)
39	42-38-0222	Rubber Bumper	(1)
40	42-42-1020	Switch Lock-Out	(1)
41	42-42-1030	Spindle Lock Button	(1)
42	43-34-0790	Inner Flange	(1)
43	43-34-0795	Outer Flange	(1)
44	44-10-0420	Guard Lever	(1)
45	44-10-0430	Depth Lever	(1)
46	44-20-0650	Spindle Lock	(1)
47	44-52-0540	Cushion Grip	(1)
48	44-60-0740	Pivot Pin	(1)
49	44-66-0560	Retaining Plate	(1)
50	45-04-0485	Bumper Screw	(1)
51	45-06-0720	Felt Seal	(1)
52	45-08-0395	Depth Shaft	(1)
53	45-88-1515	Washer	(1)
54	45-88-5615	Wave Spring Washer	(1)
55	49-96-0080	3/16 Hex Key	(1)
59	06-10-0660	1/4-20 x 1/2 Short Neck Carriage Bolt	(1)
60	45-88-1560	Washer	(1)
61	43-98-0730	Bevel Adjustment Knob	(1)
62	43-98-0720	Rip Fence Knob	(1)
63	40-50-0650	Spring	(1)
64	06-82-9605	10-32 x 3/8 CSK Machine Screw T-25	(4)
65	06-83-1600	10-32 x 3/8 Set Screw	(1)
★ 66	14-46-2570	Gear Service Assembly	(1)
	43-30-0100	Rip Fence (Not Shown)	(1)
	48-55-1490	Carrying Case (Not Shown)	(1)
	23-94-4260	Red Leadwire Assembly (Not Shown)	(1)
	23-94-4270	Black Leadwire Assembly (Not Shown)	(1)

FIG. NOTE:
1 Orient the ball bearing so that the seal faces the fan and the open side faces the gearcase.
3 Press needle bearing flush to .015 sub-flush in gearcase.
33 Position retaining ring with rounded edge facing lower guard.
46 Functionally check spindle lock. Spindle lock must return briskly when released from engagement in gear.

MILWAUKEE ELECTRIC TOOL CORPORATION
13135 W. LISBON RD., BROOKFIELD, WI 53005