

# DRILL PRESS VISES

## Continuous Nut Replacement Parts 1999 and later Models

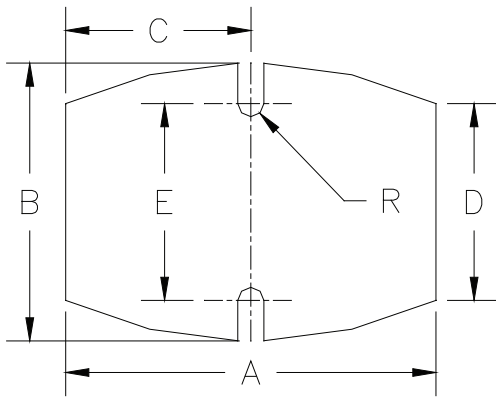

MODEL NUMBER	A	B	C	D	E	RADIUS
1335	6"	4-1/2"	3"	3"	3-3/4"	3/16" R.
1345	8"	6"	4"	4-1/4"	4-3/4"	1/4" R.
1360	10"	7-1/2"	5"	5"	6"	9/32" R.

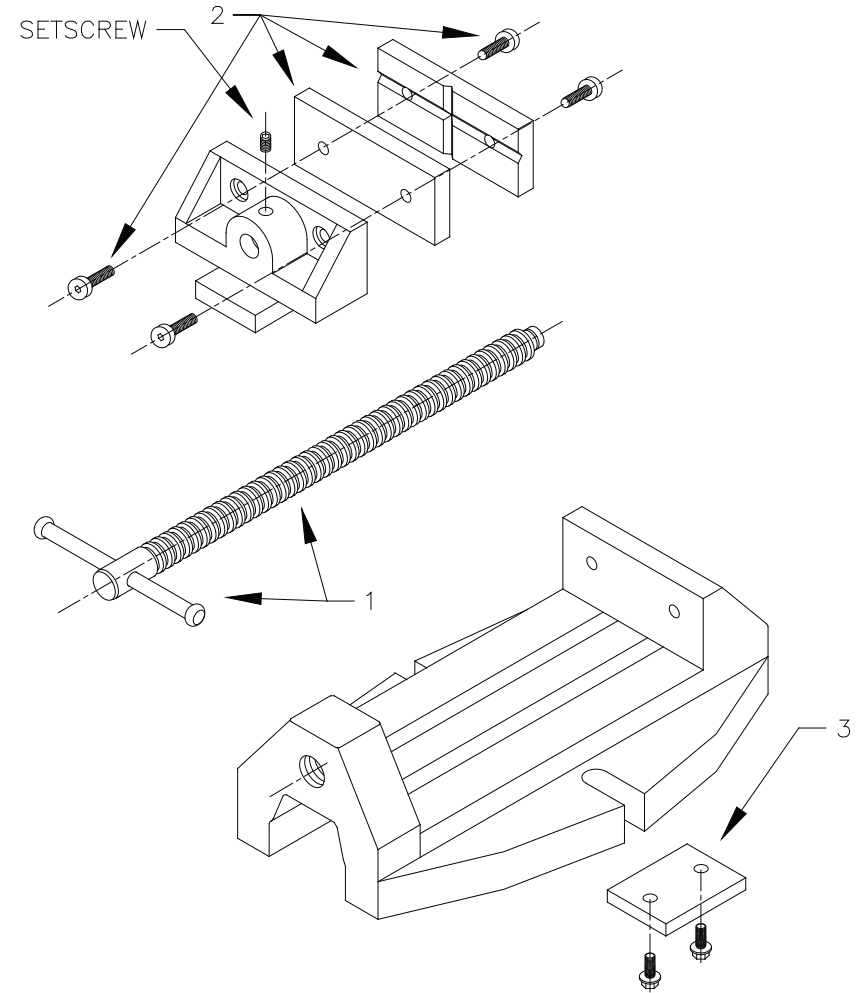

WILTON MODEL NUMBER	BASIC VISE SIZE JAW WIDTH X JAW OPENING	ITEM #1 SPINDLE WITH PIN & SETSCREW	ITEM #2 JAW INSERTS WITH SCREWS	ITEM #3 GUIDE PLATE WITH SCREWS
1335*	3" X 2-1/2"	2900370	2900360	2900380
1345**	4" X 3-3/4"	2900400	2900390	2900430
1360***	5" X 4-7/8"	2900420	2900410	2900440

\* Model 1335 replaced model 1035  
 \*\* Model 1345 replaced model 1045  
 \*\*\* Model 1360 replaced model 1060