

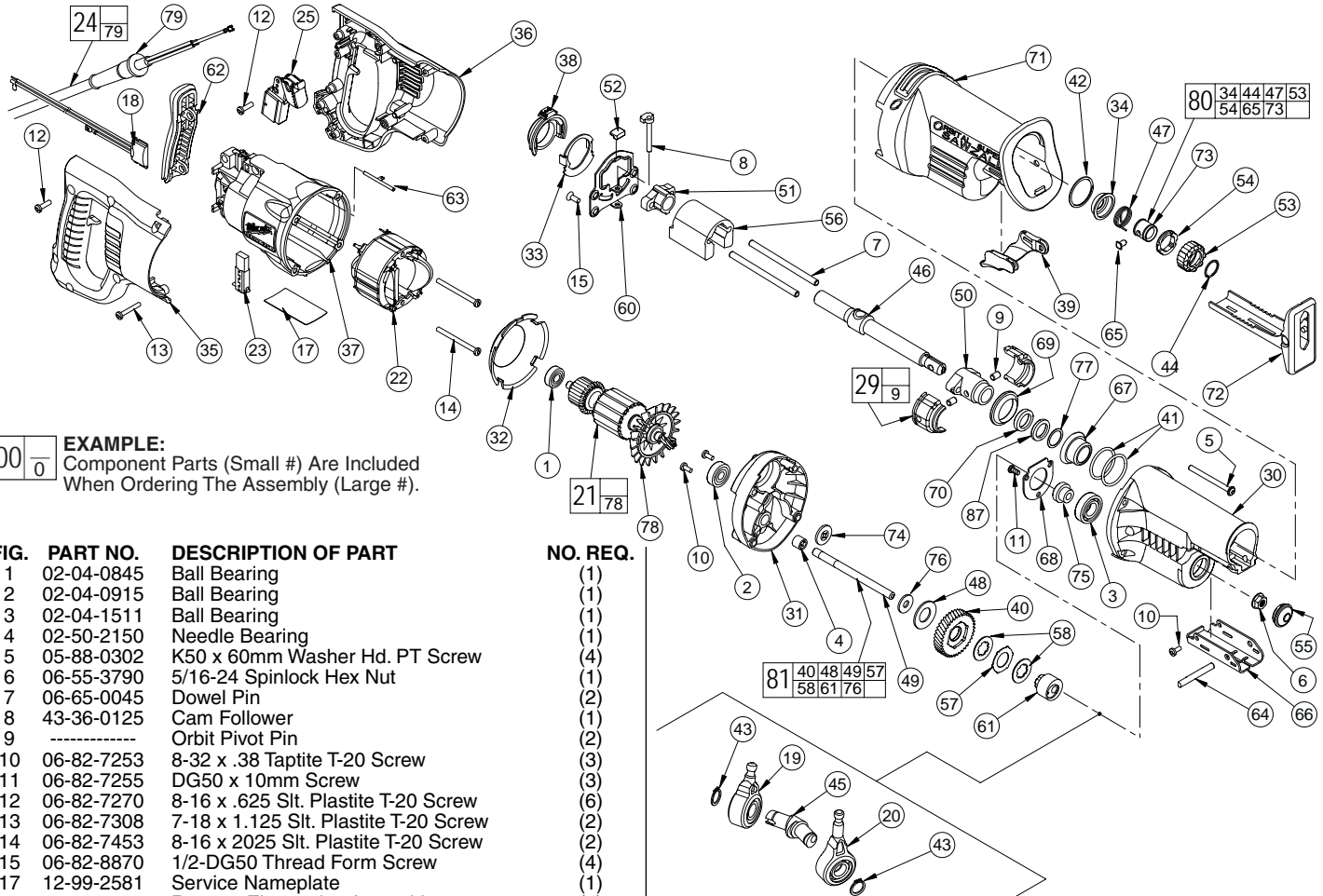

# SERVICE PARTS LIST

**BULLETIN NO.**  
**54-40-7582**

SPECIFY CATALOG NO. AND SERIAL NO. WHEN ORDERING PARTS		REVISED BULLETIN	DATE
<b>1-1/4" STROKE SAWZALL®</b>		54-40-7581	Sept. 2006
<b>CATALOG NO.</b>	<b>6536-21</b>	<b>WIRING INSTRUCTION</b>	
<b>STARTING SERIAL NO.</b>	<b>A66C</b>	<b>58-01-0055</b>	



**EXAMPLE:**  
Component Parts (Small #) Are Included  
When Ordering The Assembly (Large #).

FIG.	PART NO.	DESCRIPTION OF PART	NO. REQ.
1	02-04-0845	Ball Bearing	(1)
2	02-04-0915	Ball Bearing	(1)
★ 3	02-04-1511	Ball Bearing	(1)
4	02-50-2150	Needle Bearing	(1)
5	05-88-0302	K50 x 60mm Washer Hd. PT Screw	(4)
6	06-55-3790	5/16-24 Spinlock Hex Nut	(1)
7	06-65-0045	Dowel Pin	(2)
8	43-36-0125	Cam Follower	(1)
9	-----	Orbit Pivot Pin	(2)
10	06-82-7253	8-32 x .38 Taptite T-20 Screw	(3)
11	06-82-7255	DG50 x 10mm Screw	(3)
12	06-82-7270	8-16 x .625 Slit. Plastite T-20 Screw	(6)
13	06-82-7308	7-18 x 1.125 Slit. Plastite T-20 Screw	(2)
14	06-82-7453	8-16 x 2025 Slit. Plastite T-20 Screw	(2)
15	06-82-8870	1/2-DG50 Thread Form Screw	(4)
17	12-99-2581	Service Nameplate	(1)
18	14-20-3150	Remote Electronics Assembly	(1)
★ 19	14-67-0126	Secondary Wobble Plate Assembly	(1)
★ 20	14-67-0136	Primary Wobble Plate Assembly	(1)
21	16-30-0700	Service Armature	(1)
22	18-30-1700	Service Field	(1)
23	22-20-0590	Carbon Brush Assembly	(2)
24	22-64-1121	Cord Assembly	(1)
25	23-66-1965	Switch	(1)
29	14-30-0080	Orbit Pocket Assembly	(2)
30	28-14-2600	Gearcase	(1)
31	28-28-2600	Diaphragm	(1)
32	31-05-0155	Baffle	(1)
33	31-11-0130	Orbital Cam Plate	(1)
34	31-15-0170	Spring Cover	(1)
35	31-44-2500	Handle Half - Right	(1)
36	31-44-2501	Handle Half - Left	(1)
37	31-50-0085	Motor Housing	(1)
38	31-52-0045	Orbit Shift Lever	(1)
39	31-52-0090	Shoe Release Lever	(1)
40	32-40-2050	Intermediate Gear	(1)
41	34-40-0040	O-Ring	(2)
42	34-60-0125	Retaining Ring	(1)
43	34-60-1315	External Retaining Ring	(2)
44	34-60-3700	Retaining Ring	(1)
45	36-92-0701	Wobble Shaft	(1)
46	38-50-6400	Reciprocating Spindle	(1)
47	40-50-0162	Torsion Spring	(1)
48	40-50-8850	Disc Spring	(1)
49	42-12-0190	Wobble Shaft Axle	(1)
★ 50	42-24-0066	Front Spindle Bushing	(1)
51	42-24-0525	Rear Spindle Bushing	(1)
52	42-38-0055	Orbit Bumper	(1)
53	42-50-0355	Front Cam	(1)
54	42-50-0360	Rear Cam	(1)
55	42-52-0380	Bearing Cap	(1)
56	42-87-0180	Counter Weight	(1)
57	43-06-0676	Bronze Plate	(1)

FIG.	PART NO.	DESCRIPTION OF PART	NO. REQ.
58	43-06-0685	Metal Plate	(2)
60	43-56-0620	Orbit Plate	(1)
61	43-78-0575	Orbit Drive Hub	(1)
62	44-52-1000	Cushion Grip	(1)
63	44-60-0530	Grounding Pin	(1)
64	44-60-1635	Shoe Pin	(1)
65	44-60-1750	Lock Pin	(1)
66	44-66-0880	Shoe Retainer	(1)
67	44-86-0035	Front Orbit Cap	(1)
68	44-86-0655	Bearing Retainer	(1)
69	45-06-0110	Orbit Seal	(1)
70	45-06-0475	Polypak Seal	(1)
71	45-12-0700	Gearcase Insulator	(1)
72	45-16-0645	Shoe Assembly	(1)
73	45-22-0175	Sleeve	(1)
74	45-28-0555	Slinger	(1)
75	45-36-1445	Spacer	(1)
76	45-88-1555	Washer	(1)
77	45-88-8577	Washer	(1)
78	22-84-0531	Fan	(1)
79	44-76-0210	Cord Protector	(1)
80	14-46-1060	Large Quik-Lok Blade Clamp	(1)
81	14-08-0075	Gear Protecting Clutch Assembly	(1)
87	45-06-0501	Felt Seal	(1)
	23-94-0025	Ground Wire Assembly	(1)
	23-94-6750	Leadwire Assembly	(1)
	23-94-6755	Leadwire Assembly	(1)

**SEE REVERSE SIDE FOR IMPORTANT SERVICE NOTES**

**MILWAUKEE ELECTRIC TOOL CORPORATION**  
13135 W. LISBON RD., BROOKFIELD, WI 53005

FIG. 1

**NOTES:**

Bearing to be installed with seal towards commutator.

4,31 Press needle bearing flush  $\pm .005$  with inner surface of diaphragm.

6,49 Apply Blue Loctite® 242 to treads of wobble shaft axle prior to installing spinlock hex nut. Torque spinlock hex nut to 160-190 in. lbs.

6,40 Hold the intermediate gear still with a large pair of pliers and a piece of rubber hose (or other tough, but pliable material to protect the gear from the jaws of the pliers) and remove the 5/16" spinlock hex nut with a wrench, as shown.

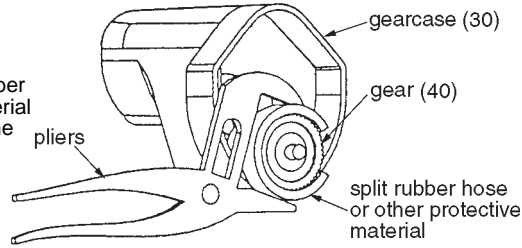

7,46,50,51,56 Press dowel pins flush to front side of front spindle bushing. Press dowel pins flush to back side of rear spindle bushing. **NOTE:** Reciprocating spindle (46) and counter weight (56) must be installed inside assembly (7,50) and (7,51) prior to pressing last spindle bushing into place. Be sure to orientate the counter weight with the hole on bottom towards rear spindle bushing, as shown.

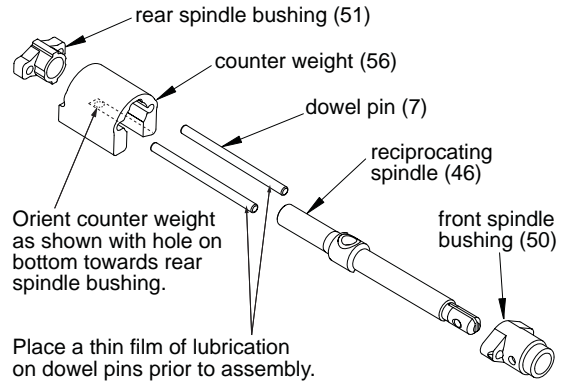

17,37 Install nameplate in motor housing recess prior to assembling diaphragm onto motor housing.

29,42 **Service fixture #61-10-0205** must be used when installing retaining ring (42) onto orbit pocket assembly (29).

40,57 Tabs of bronze plate engage intermediate gear.

40,48 Concave side of disc spring towards intermediate gear.

58,61 Tabs of metal plates engage orbit drive hub.

70 O-ring of polypak seal faces mechanism - toward rear of tool.

74 Shoulder extension of grease slinger should face bearing.

**REMOVING THE STEEL QUIK-LOK® BLADE CLAMP**

- Remove external retaining ring (44) and pull front cam (53) off.
- Pull lock pin (65) out and remove remainder of parts and discard.

**REASSEMBLY OF THE STEEL QUIK-LOK® BLADE CLAMP**

- Coat new lock pin with powdered graphite.
- Hold tool in a vertical position.
- Place spring cover (34) onto spindle.
- Slide torsion spring (47) onto spindle shaft with leg positioned at the 6:00 position.
- Slide sleeve (73) onto spindle aligning hole on sleeve with hole in spindle.
- Slide rear cam (54) over sleeve, aligning hole in rear cam with spring leg. Ensure spring leg inserts into hole in rear cam.
- Rotate rear cam (54) counter clockwise until there is clearance for lock pin (65) to be inserted into sleeve/spindle holes. Insert lock pin.
- Align front cam (53) inner ribs with rear cam outer slots (*see insert*) and slide front cam onto sleeve until it bottoms. Retaining ring (44) groove should be completely visible.
- Attach retaining ring by separating coils and inserting end of ring into groove, then wind remainder of ring into groove. Ensure ring is seated in groove.
- Blade clamp should rotate freely. During normal usage, debris may not allow blade clamp to rotate freely. The use of spray lubricant can help free blade clamp. In extreme conditions, follow these instructions to remove, clean and reassemble blade clamp.

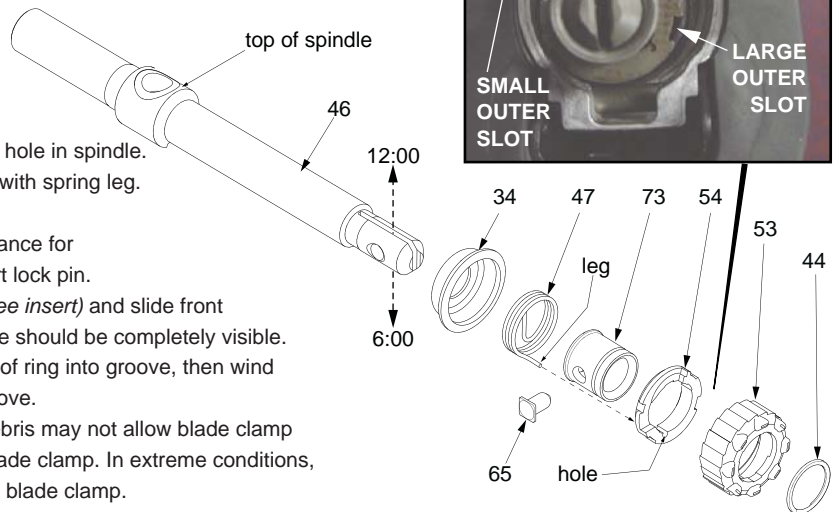

**FIG. LUBRICATION:**

29,41 Lightly coat o-rings with lubrication for ease of installation onto assembled orbit pockets.

30 Place 3.2 oz. (80 grams  $\pm$  8 grams) of type "T" grease (Cat. No. 49-08-4290), in mechanism cavity of gear case.

31 Place .8 oz. (20 grams  $\pm$  2 grams) of type "T" grease (Cat. No. 49-08-4290), in lower needle bearing-gear train cavity of diaphragm.

40,58 Apply a thin coat of type "T" grease (Cat. No. 49-08-4290) between gear and metal plate.

65 Pin to be coated with graphite prior to assembly.

87 Soak in lightweight bushing oil prior to assembly.

