



SERVICE PARTS LIST

BULLETIN NO.
54-42-5513

SPECIFY CATALOG NO. AND SERIAL NO. WHEN ORDERING PARTS		REVISED BULLETIN	DATE
SNAP ACTION CLUTCH SCREWDRIVER		54-42-5512	Jan. '96
CATALOG NO. 6798-1	STARTING SERIAL NO. 450E	WIRING INSTRUCTION 58-01-0031	

EXAMPLE:

00	0
----	---

 Component Parts (Small #) Are Included
 When Ordering The Assembly (Large #).

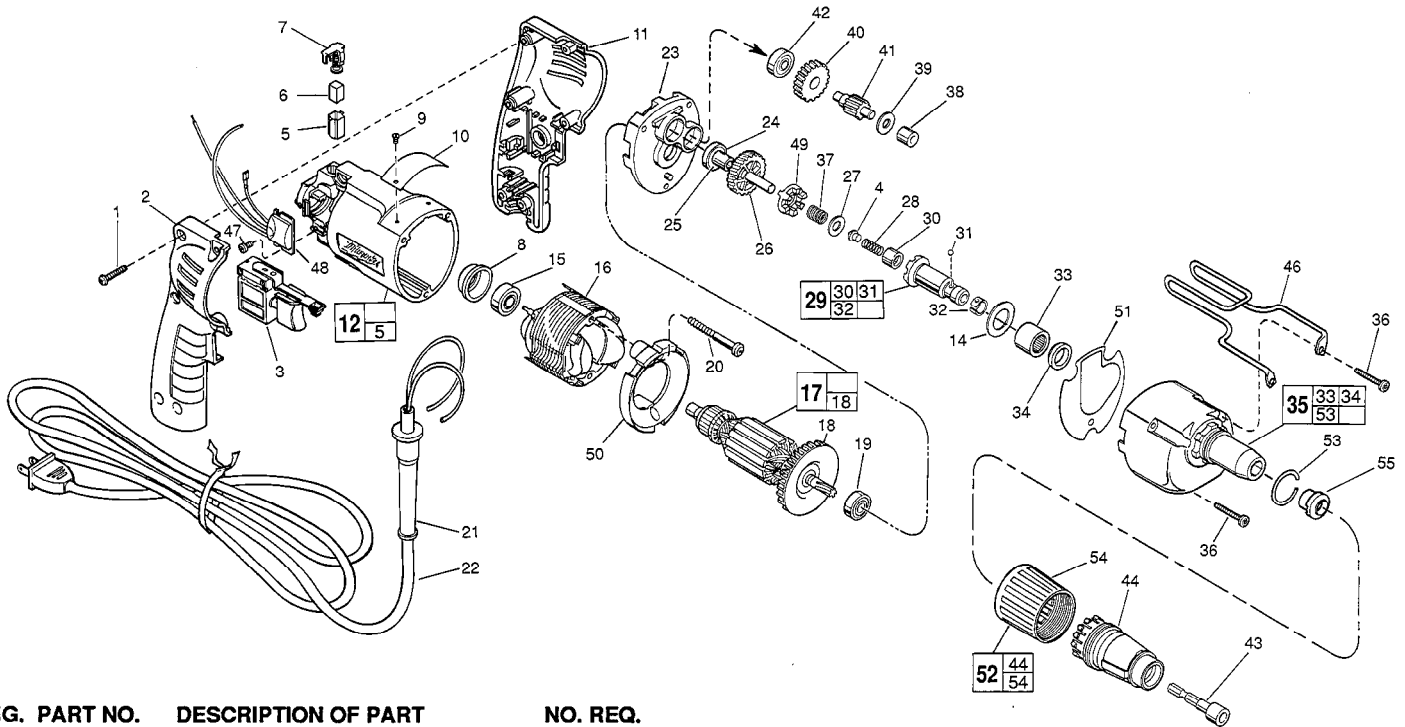

FIG.	PART NO.	DESCRIPTION OF PART	NO. REQ.
	1	06-82-7284 8-16 x 3/4" Pan Hd. Slit. Plast. T-20	(6)
	2	31-44-1745 Right Handle Half	(1)
	3	23-66-2145 Speed Control Switch	(1)
★	4	44-60-0505 Thrust Pin	(1)
	5	22-20-0830 Brush Tube	(2)
	6	22-16-0275 Carbon Brush	(2)
	7	23-52-1570 Brush Spring Assembly	(2)
	8	22-72-0100 Bearing Cup	(1)
	9	06-72-1720 Nameplate Rivet	(2)
	10	12-99-0860 Service Nameplate	(1)
	11	31-44-1740 Left Handle Half	(1)
	12	14-38-0591 Motor Housing Assembly	(1)
★	14	45-88-8350 Stop Washer	(1)
	15	02-04-0645 Ball Bearing	(1)
	16	18-11-0150 120 Volt Field	(1)
	17	16-10-0700 120 Volt Armature	(1)
	18	22-84-0880 Fan Assembly	(1)
	19	02-04-0851 Ball Bearing	(1)
	20	06-82-7203 7-18 x 2-1/8" Pan Hd. Slit. Plast. T-20	(2)
	21	44-76-0210 Cord Protector	(1)
	22	22-64-0891 Cord Set	(1)
★	23	28-28-2310 Diaphragm	(1)
	24	02-04-0645 Ball Bearing	(1)
	25	45-36-1280 Spacer	(1)
★	26	32-10-4060 Clutch Gear Assembly	(1)
★	27	45-88-0555 Thrust Washer	(1)
★	28	40-50-0095 Separator Spring	(1)
★	29	42-66-0710 Clutch Chuck Assembly	(1)
	30	02-50-2400 Needle Bearing	(1)
	31	02-02-0130 Steel Ball	(1)
	32	40-50-0510 Bit Retaining Spring	(1)
	33	02-50-4220 Needle Roller Bearing	(1)
	34	45-06-0570 Oil Seal	(1)
★	35	14-30-0745 Gear Case Assembly	(1)
★	36	06-82-7344 7-18 x 1-1/2" Pan Hd. Slit. Plast. T-20	(3)
★	37	40-50-8515 Bias Spring	(1)
	38	02-50-2400 Needle Bearing	(1)
	39	45-88-7990 Thrust Washer	(1)
★	40	32-40-1614 Intermediate Gear	(1)
★	41	36-66-9680 Intermediate Pinion Shaft	(1)
	42	02-04-0645 Ball Bearing	(1)
	43	49-66-3016 5/16" Hex Socket	(1)
★	44	31-51-0105 Tek Locator	(1)

FIG.	PART NO.	DESCRIPTION OF PART	NO. REQ.
	46	42-70-5080 Belt Clip	(1)
	47	06-82-7212 4-20 x 1/4" Pan Hd. Slit. Plast. T-10	(1)
	48	14-20-0750 Remote Electronic Assembly	(1)
★	49	42-70-0310 Drive Clutch	(1)
	50	42-14-0380 Baffle	(1)
★	51	43-44-4010 Gasket	(1)
★	52	49-26-1081 Tek Locator Assembly	(1)
	53	44-90-0401 Locator Ring	(1)
	54	31-58-0510 Locator Sleeve	(1)
★	55	30-37-0055 Nose Guide	(1)

FIG. LUBRICATION
 17,26,37 1/64 Oz. Type "E" Grease, No. 49-08-4122, On Bias Spring.
 1/64 Oz. In The Clutch Pockets Of The Clutch Gear.
 1/64 Oz. On Each Side Of Armature Pinion At Clutch Gear.
 35 7/8 Oz. In Pinion Pocket Of Gear Case, Near Intermediate Shaft Needle Bearing In Gear Case.

Apply A Light Film Of "E" Grease To Ball And Needle Bearing Pockets Of The Diaphragm And Gear Case Prior To Pressing Bearings. Apply A Light Film Of "E" Grease To The Lead Chamfer Of Clutch Chuck, Thrust Pin And Separator Spring Prior To Assembly.

FIG.	NOTES
1	Torque to 18-28 In./Lbs.
20,36	Torque to 15-20 In./Lbs.
47	Torque to 3-5 In./Lbs.
8	Place in motor housing before inserting armature.
30,33,38	Press only on end with manufacturer ID.
33,38	Press flush to casting surface.
34	Spring side towards rear of gear case.
15	Seal towards armature.
24,42	Seal Away From Armature

MILWAUKEE ELECTRIC TOOL CORPORATION
 13135 W. LISBON RD., BROOKFIELD, WI 53005