



SERVICE PARTS LIST

BULLETIN NO.
55-44-0614

SPECIFY CATALOG NO. AND SERIAL NO. WHEN ORDERING PARTS		REVISED BULLETIN	DATE
16 GAUGE SHEAR		55-44-0613	Mar.'94
CATALOG NO.	6805-2	WIRING INSTRUCTION	
STARTING SERIAL NO.	709B	58-01-0309	

EXAMPLE:
Component Parts
(Small #) Are Included
When Ordering
The Assembly
(Large #).

00
0

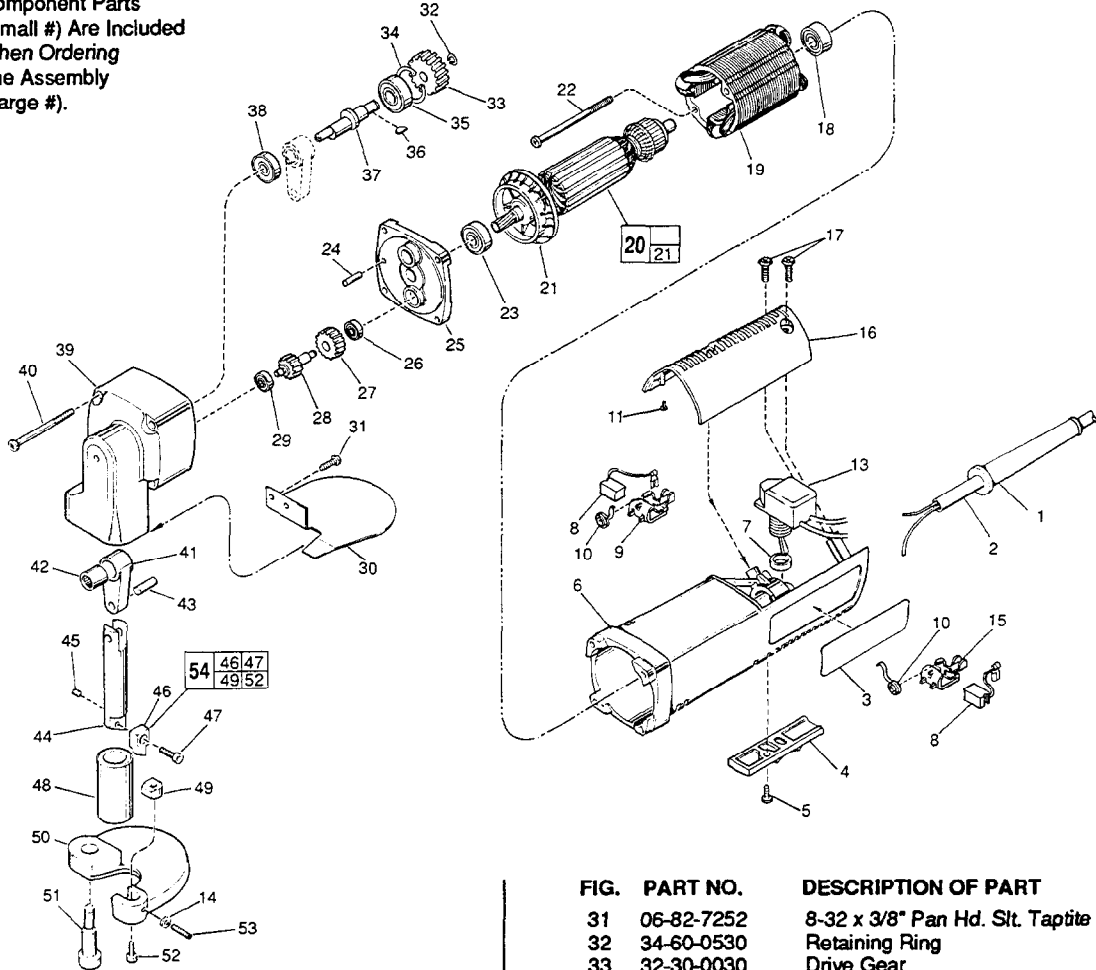

FIG.	PART NO.	DESCRIPTION OF PART	NO. REQ.
1	44-76-0130	Cord Protector	(1)
2	22-64-0235	Cord Set	(1)
3	12-20-0540	Service Nameplate Kit	(1)
★ 4	31-55-0156	Trigger Cover	(1)
5	06-82-7409	8-16 x 1/2" Pan Hd. Stt. Plastite T-20	(1)
6	31-50-0425	Motor Housing	(1)
7	44-90-4245	Rubber Ring	(1)
8	22-18-0750	Carbon Brush Assembly	(2)
9	22-20-0692	Right Brush Holder	(1)
10	23-52-0240	Brush Spring	(2)
11	42-38-0181	Rubber Bumper	(2)
★ 13	23-66-2190	Switch	(1)
14	06-55-0825	8-32 Hex Nut	(1)
15	22-20-0691	Left Brush Holder	(1)
16	31-15-0143	Cover	(1)
17	06-82-7270	8-16 x 5/8" Plastite T-20 Screw	(3)
18	02-04-0850	Ball Bearing	(1)
19	18-06-0055	240 V. Field	(1)
20	16-06-0090	240 V. Armature	(1)
21	22-84-0680	Fan	(1)
22	06-82-7375	8-16 x 2-1/2" Plastite T-20 Screw	(2)
23	02-08-0375	Ball Bearing	(1)
24	06-65-0825	1/8 x 1/2 Groove Pin No. 5	(1)
25	28-28-1670	Diaphragm	(1)
26	02-08-0200	Ball Bearing	(1)
27	32-40-1910	Intermediate Gear	(1)
28	36-66-4350	Intermediate Pinion Shaft	(1)
29	02-08-0200	Ball Bearing	(1)
30	43-54-0520	Guard	(1)

FIG.	PART NO.	DESCRIPTION OF PART	NO. REQ.
31	06-82-7252	8-32 x 3/8" Pan Hd. Stt. Tapite T-20	(2)
32	34-60-0530	Retaining Ring	(1)
33	32-30-0030	Drive Gear	(1)
34	34-80-1505	Internal Retaining Ring	(1)
35	02-04-1022	Ball Bearing	(1)
36	06-42-0800	Woodruff Key	(1)
37	43-16-0180	Eccentric Shaft	(1)
38	02-04-0710	Ball Bearing	(1)
39	28-14-1575	Gear Case	(1)
40	06-82-7410	8-16 x 1-7/8" Plastite T-20 Screw	(4)
41	44-94-0210	Connecting Rod	(1)
42	02-50-2501	Needle Bearing	(1)
43	06-65-1310	Dowel Pin	(1)
44	38-50-5420	Spindle	(1)
45	44-46-0200	Felt Oiler	(1)
46		Top Shear Blade	(1)
47	06-75-2055	8-32 x 1/2" Large Skt. Hd. Screw	(1)
48	42-40-0395	Spindle Bushing	(1)
49		Bottom Shear Blade	(1)
50	30-99-0080	Yoke	(1)
51	45-04-0680	Shoulder Screw	(1)
52	06-75-2000	8-32 x 3/8" Skt. Hd. Screw	(1)
53	06-83-1900	8-32 x 1/2" Skt. Hd. Set Screw	(1)
54	48-44-0122	Shear Blade Kit	(1)
	49-11-0080	Feeler Gauge	(1)
	49-96-0040	5/64" Socket Wrench	(1)
	49-96-0065	9/64" Socket Wrench	(1)

FIG. LUBRICATION
39 3/4 Oz. Type "G" Grease, No. 49-08-4140.
44/48 Coat Spindle with Type "G" Grease Before
Assembly with Spindle Bushing.

MILWAUKEE ELECTRIC TOOL CORPORATION
13135 W. LISBON RD., BROOKFIELD, WI 53005