



SERVICE PARTS LIST

BULLETIN NO.
55-27-0653

SPECIFY CATALOG NO. AND SERIAL NO. WHEN ORDERING PARTS		REVISED BULLETIN	DATE
10 GAUGE NIBBLER		55-27-0652	Mar.'94
CATALOG NO.	6880-2	WIRING INSTRUCTION	
STARTING SERIAL NO.	630B	58-01-0309	

EXAMPLE:
Component Parts
(Small #) Are Included
When Ordering The
Assembly (Large #).

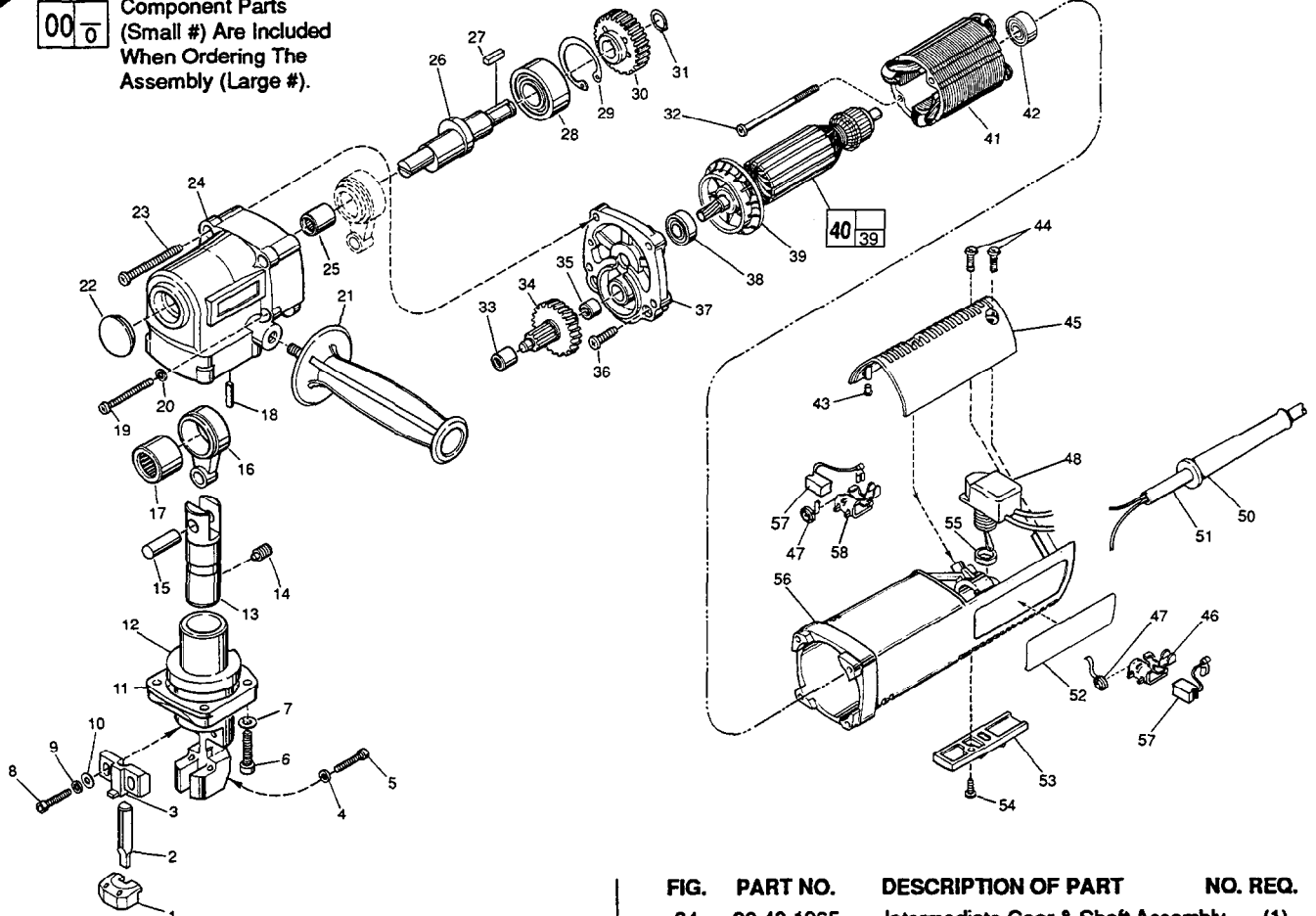

FIG.	PART NO.	DESCRIPTION OF PART	NO. REQ.
1	48-44-0275	Die	(1)
2	48-44-0265	Punch	(1)
3	43-56-0400	Punch Guide	(1)
4	05-90-0105	Lockwasher	(2)
5	05-74-0520	M5x.8x20 Socket Hd. Cap Screw	(2)
6	05-74-0625	Socket Hd. Cap Screw	(4)
7	05-90-0106	Lockwasher	(4)
8	05-74-0520	M5x.8x20 Socket Hd. Cap Screw	(2)
9	05-90-0105	Lockwasher	(2)
10	45-88-7945	Flat Washer	(2)
11	44-86-0455	Retainer	(1)
12	43-72-0155	Die Holder Assembly	(1)
13	44-62-0175	Piston	(1)
14	05-86-0818	M8 x 18 Socket Set Screw	(1)
15	06-65-1320	Dowel Pin	(1)
16	44-94-0215	Connecting Rod	(1)
17	02-50-4840	Needle Bearing	(1)
18	44-60-0910	Locating Pin	(1)
19	05-74-0541	M5 x 40 Phillips Mach. Screw	(2)
20	05-90-0105	Lockwasher	(2)
21	43-62-0880	Side Handle	(1)
22	42-53-0090	Cap	(1)
23	06-95-3310	8-16 x 2" Pan Hd. Screw	(2)
24	28-14-1865	Gear Case	(1)
25	02-50-3240	Needle Bearing	(1)
26	43-16-0195	Eccentric Shaft	(1)
27	43-96-0145	Square Key M5 x 12	(1)
28	02-20-1800	Ball Bearing	(1)
29	34-80-0205	Internal Retaining Ring	(1)
30	32-30-0055	Drive Gear	(1)
31	34-60-2360	Snap Ring	(1)
32	06-82-7375	8-16 x 2-1/2" Plastite T-20 Screw	(2)
33	02-50-2016	Needle Bearing	(1)

FIG.	PART NO.	DESCRIPTION OF PART	NO. REQ.
34	32-40-1965	Intermediate Gear & Shaft Assembly	(1)
35	02-50-2015	Needle Bearing	(1)
36	06-82-7270	8-16 x 5/8" Plastite T-20 Screw	(2)
37	28-28-1795	Diaphragm	(1)
38	02-08-0375	Ball Bearing	(1)
39	22-84-0680	Fan	(1)
40	16-06-0090	240 Volt Armature	(1)
41	18-06-0055	240 Volt Field	(1)
42	02-04-0844	Ball Bearing	(1)
43	42-38-0181	Rubber Bumper	(2)
44	06-82-7270	8-16 x 5/8" Plastite T-20 Screw	(3)
45	31-15-0143	Cover	(1)
46	22-20-0691	Left Brush Holder	(1)
47	23-52-0240	Brush Spring	(2)
★ 48	23-66-2190	Switch	(1)
50	44-76-0130	Cord Protector	(1)
51	22-64-0235	Cord Set	(1)
52	12-20-0585	Service Nameplate Kit	(1)
★ 53	31-55-0156	Trigger Cover	(1)
54	06-82-7409	8-16 x 1/2" Plastite T-20 Screw	(1)
55	44-90-4245	Rubber Ring	(1)
56	31-50-0425	Motor Housing	(1)
57	22-18-0750	Carbon Brush Assembly	(2)
58	22-20-0692	Right Brush Holder	(1)
	49-96-0350	4MM Allen Wrench	(1)
	10-98-6470	Milwaukee Label	(2)

FIG. NOTES
9,23,36 Torque to 20-25 in./lbs.

FIG. LUBRICATION
24 3/4 Oz. Type "G" Grease, No. 49-08-4140.

MILWAUKEE ELECTRIC TOOL CORPORATION
13135 W. LISBON RD., BROOKFIELD, WI 53005