



Operating Instructions and Parts Manual Woodworking Band Saws

Model JWBS-15, JWBS-18, JWBS-20



For serial nos.:

JWBS-15: 17120226 and higher
JWBS-17: 18030001 and higher
JWBS-18: 17110021 and higher

JWBS-20 shown

JET
427 New Sanford Road
LaVergne, Tennessee 37086
Ph.: 800-274-6848
www.jettools.com

Part No. M-714600
Edition 5 09/2018
Copyright © 2017 JET

13.10.1 JWBS-18 Bandsaw Assembly – Exploded View

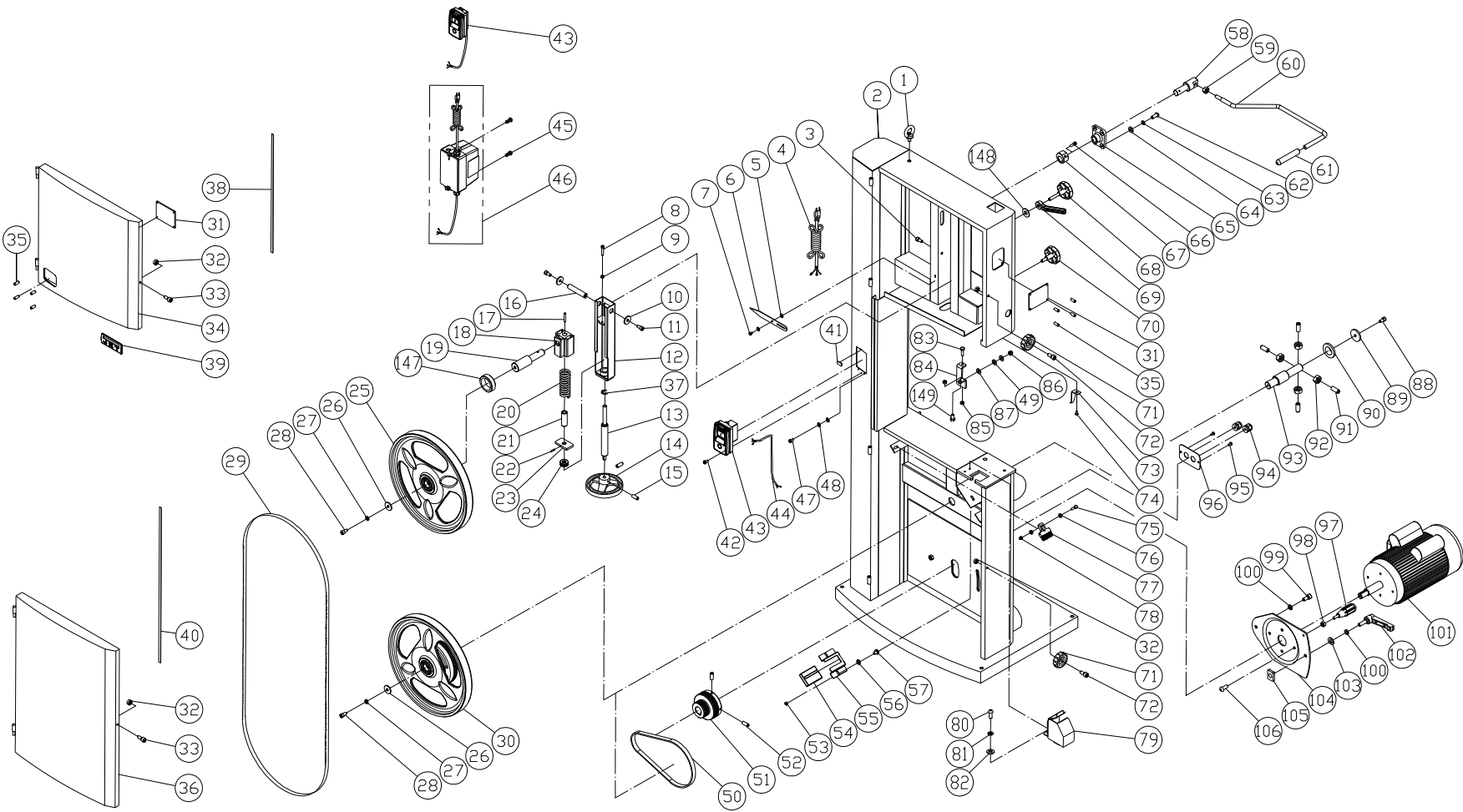

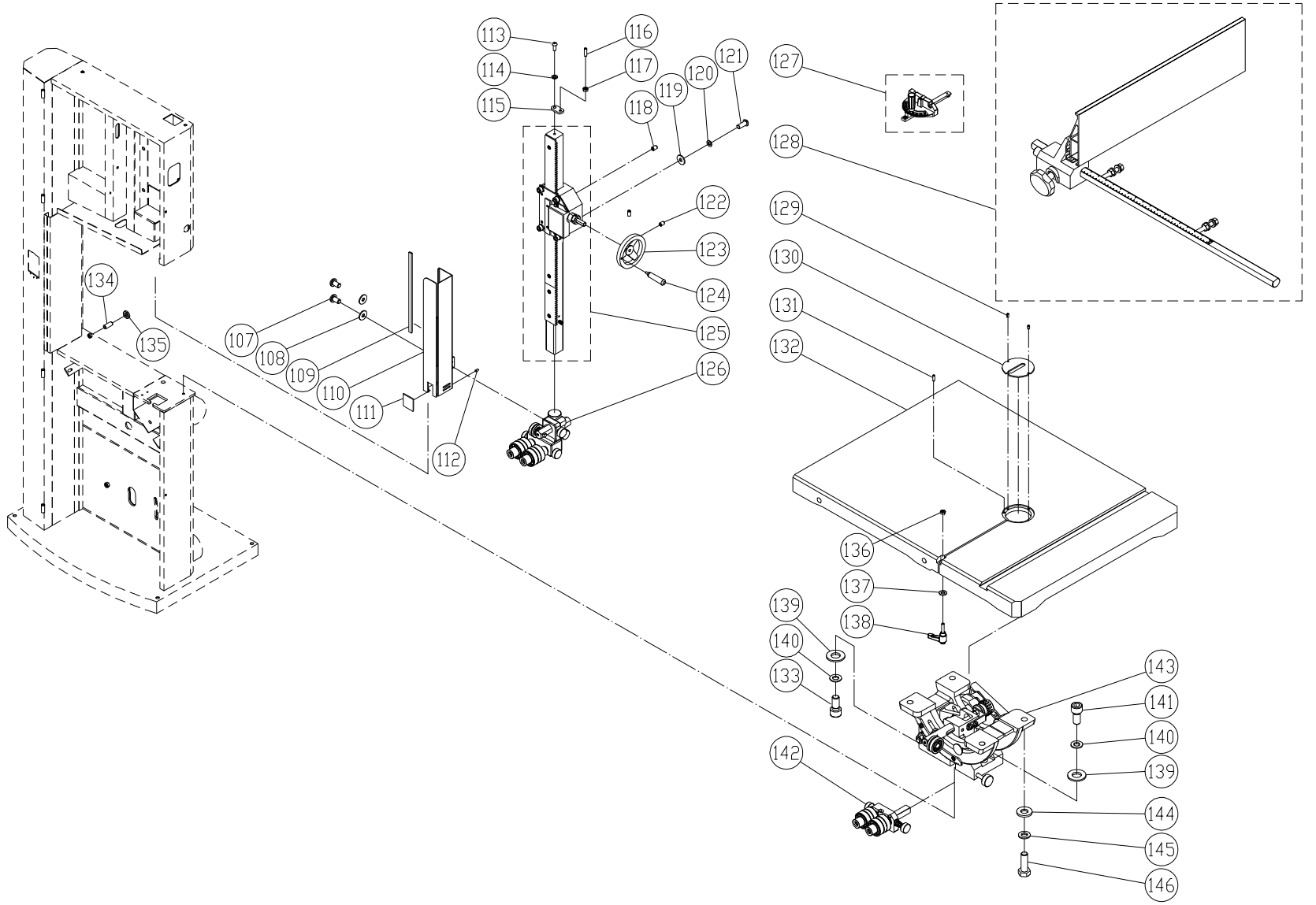

13.10.2 JWBS-18 Bandsaw Assembly – Parts List

Index No.	Part No.	Description	Size	Qty
1	PM1500-004	Lifting Ring	M10	1
2	JWBS18B-102	Machine Main Body Frame		1
3	TS-1482021	Hex Cap Bolt	M6x12	1
4	JWBS15-104	Power Cord	1-3/4HP	1
	JWBS15-104B	Power Cord	3HP	1
5	TS-1550041	Flat Washer	M6	2
6	JWBS18B-106	Tension Pointer		1
7	PM1500-012	Step Screw		1
8	TS-1503111	Socket Head Cap Screw	M6x50	1
9	TS-2311061	Hex Nut	M6	1
10	TS-1550061	Flat Washer	M8	2
11	TS-1504031	Socket Head Cap Screw	M8x16	2
12	JWBS15-112	Upper Wheel Sliding Bracket		1
13	JWBS18B-113	Adjusting Bolt		1
14	JWBS15-114	Handwheel	6"	1
15	TS-1503051	Socket Head Cap Screw	M6x20	2
16	JWBS15-116	Upper Shaft		1
17	JWBS15-117	Spring Pin	Ø5x36mm	1
18	JWBS15-118	Upper Wheel Sliding Bracket		1
19	JWBS18B-119	Upper Wheel Shaft		1
20	JWBS15-120	Spring		1
21	PM1500-010-02	Bushing		1
22	JWBS15-122	Pin	Ø 3x20mm	1
23	JWBS15-123	Locate Block		1
24	BB-51201	Bearing	51201	1
25	PM1800B-018	Upper Wheel Assembly	Ø18"	1
26	PM1800B-017	Washer		2
27	TS-2361081	Spring Washer	M8	2
28	TS-1504041	Socket Head Cap Bolt	M8x20	2
29	JWBS18B-129	Saw Blade	150"L x 3/4" x 0.026" T x 6 TPI	1
30	JWBS18B-130	Lower Wheel Assembly	Ø18"	1
31	PM1500-050	Viewing Window		2
32	TS-1541021	Nylon Nut	M6	4
33	TS-1503021	Socket Head Cap Screw	M6x10	2
34	JWBS18B-134	Upper Door		1
35	JWBS15-135	Socket Head Cap Screw	M4x8	8
36	JWBS18B-136	Lower Door		1
37	PM1800B-027-026	Retaining Ring (E)	E15	1
38	JWBS15-138	Sponge		1
39	JET-138-R2000	Jet Logo	138x57mm	1
40	JWBS15-140	Sponge	760x10x1T mm	1
41	JWBS15-141	Sponge	16x5x2T mm	1
42	TS-1532032	Pan Head Screw	M4x10	1
43	JOSS-S-213	On/Off Switch Assembly	1-3/4HP	1
	JOSS-S-213SK	Safety Key for JOSS-S-213 (not shown)		1
	JWBS15-143B	Control Switch Assembly	3HP	1
	JWBS15-143BSK	Safety Key for JWBS15-143B (not shown)		1
44	JWBS15-144	Motor Cord	14AWGx3C	1
45	TS-1533052	Pan Head Screw	M5x16	2
46	JWBS15-146	Magnetic Switch Assembly	3HP only	1
	JWBS15-146CS	Contact Switch		1
	JWBS15-146OP	Overload Protector		1
47	TS-1533032	Pan Head Screw	M5x10	2
48	TS-0733041	Ext. Tooth Lock Washer	M5	4
49	PM1800B-159	Special Washer	16x8.2x0.4T	2
50	JWBS18B-150	Poly-V Belt	430J10	1
51	JWBS18B-151	Motor Pulley		1
52	TS-1523041	Set Screw	M6x12	2
53	TS-2311061	Hex Nut	M6	2
54	JWBS18DX-249	Dust Collect Insert		1

Index No.	Part No.	Description	Size	Qty
55	JWBS15-155	Fixed Plate		1
56	TS-2361061	Spring Washer	M6	2
57	TS-2246122	Socket Head Button Screw	M6x12	2
58	PM1500-074	Tension Quick Release Lever Shaft		1
59	TS-1540083	Hex Nut	M12	1
60	JWBS18B-160	Tension Quick Release Lever		1
61	JWBS15-161	Grip		1
62	TS-2248202	Socket Head Button Screw	M8x20	4
63	TS-2361081	Spring Washer	M8	4
64	TS-1550061	Flat Washer	M8xØ18	4
65	PM1500-070	Shaft Fixed Block		1
66	TS-1503061	Socket Head Cap Screw	M6x25	1
67	PM1500-069	Cam		1
68	JWBS15-168	Lock Knob	M10x53	1
69	PM1500-068	Lock Handle	M10	1
70	JWBS15-170	Lock Knob	M10x25	1
71	135041	Knob		2
72	TS-1503051	Socket Head Cap Screw	M6x20	2
73	JWBS15-173	Pointer		1
74	6286494	Pan Head Screw	M5x6	1
75	TS-1482051	Hex Cap Screw	M6x25	1
76	TS-1550041	Flat Washer	M6	2
77	PM1500-058	Brush		1
78	TS-1541021	Hex Nylon Lock Nut	M6	1
79	JWBS18B-179	Lower Blade Guard		1
80	TS-2246082	Socket Head Button Screw	M6x8	2
81	TS-2361061	Lock Washer	M6	2
82	TS-1550041	Flat Washer	M6	2
83	TS-1490071	Hex Cap Screw	M8x40	1
84	JWBS15-184	Support Plate		1
85	TS-1541031	Hex Nut	M8	2
86	TS-1541031	Nylon Nut	M8	1
87	TS-1550061	Flat Washer	M8	2
88	TS-1504041	Socket Head Cap Screw	M8x20	1
89	PM1800B-088	Washer		1
90	PM1800B-087	Plate		1
91	TS-2279301	Set Screw	M10x30	4
92	TS-1541041	Hex Nut	M10	4
93	PM1800B-084	Lower Wheel Shaft		1
94	PM1500-062	Strain Relief	PG13.5	2
95	PM1500-039	Tapping Screw	M4x8	2
96	PM1500-083	Strain Relief Fixed Plate	1-3/4 HP	1
	JWBS15-196A	Strain Relief Fixed Plate	3HP	1
97	JWBS15-197	Handle		1
98	TS-1540061	Hex Nut	M8	1
99	TS-149105	Hex Cap Screw	M10x35	1
100	TS-2361101	Spring Washer	M10	2
101	JWBS18B-1101	Motor	1-3/4HP	1
	JWBS18B-1101FM	Motor Fan (not shown)		1
	JWBS18B-1101FMC	Motor Fan Cover (not shown)		1
	JWBS18B-1101SC	Start Capacitor (not shown)	300MFD, 250VAC	1
	JWBS18B-1101RC	Running Capacitor (not shown)	40µF, 250VAC	1
	JWBS18B-1101JB	Junction Box (not shown)		1
	JWBS18B-1101JBC	Junction Box Cover (not shown)		1
	JWBS18B-1101CS	Centrifugal Switch (not shown)		1
	JWBS18B-1101A	Motor	3HP/230V	1
	JWBS18B-1101AMF	Motor Fan (not shown)		1
	JWBS18B-1101AMFC	Motor Fan Cover (not shown)		1
	JWBS18B-1101ASC	Start Capacitor (not shown)	300MFD, 250VAC	1
	JWBS18B-1101ARC	Running Capacitor (not shown)	60µF, 300VAC	1
	JWBS18B-1101AJB	Junction Box (not shown)		1
	JWBS18B-1101AJBC	Junction Box Cover (not shown)		1

Index No.	Part No.	Description	Size	Qty
	JWBS18B-1101ACS	Centrifugal Switch (not shown)		1
102	PM1500-015	Motor Bracket Lock Handle	M10x33	1
103	TS-1550071	Flat Washer	M10	1
104	JWBS15-1104	Motor Bracket		1
105	PM1500-038	Locating Block		1
106	TS-2248202	Socket Head Button Screw	M8x20	4
107	TS-1482031	Hex Cap Screw	M6x16	2
108	TS-1550071	Flat Washer	M6	2
109	JWBS15-1109	Magnet	7x340mm	1
110	JWBS18B-1110	Blade Guard Cover		1
111	PM1800B-093	Viewing Window		1
112	TS-1521011	Set Screw	M4x4	2
113	TS-2246122	Socket Head Button Screw	M6x12	1
114	TS-2361061	Spring Washer	M6	1
115	PM1800B-163	Locate Plate		1
116	F010432	Set Screw	M6x35	1
117	TS-1540041	Hex Nut	M6	1
118	5302731	Set Screw	M8x6	4
119	TS-1550061	Flat Washer	M8	4
120	TS-2361081	Spring Washer	M8	4
121	TS-2248202	Socket Head Button Screw	M8x20	4
122	TS-1523041	Set Screw	M6x12	2
123	JWBS15-1118	Handwheel	5"	1
124	JWBS15-1119	Handle	M8	1
125	JWBS18B-1125	Guide Bar Bracket Assembly		1
126	JWBS18B-1126	Upper Blade Guide Assembly		1
127	JWBS15-1122	Miter Gauge Assembly		1
128	JWBS18B-1128	Rip Fence Assembly		1
129	F012085	Roll Pin	Ø4x8 mm	2
130	JWBS15-1125	Table Insert		1
131	TS-1522011	Set Screw	M5x5	3
132	JWBS18B-1132	Table		1
133	TS-149105	Hex Cap Screw	M10x35	1
134	7015-48	Set Screw	M8x30	1
135	TS-1541031	Hex Nylon Lock Nut	M8	1
136	TS-1540061	Hex Nut	M8	1
137	TS-1550061	Flat Washer	M8	1
138	JWBS18B-1138	Handle	M8x35	1
139	TS-1550071	Flat Washer	M10	2
140	TS-2361101	Spring Washer	M10	2
141	TS-1505051	Socket Head Cap Screw	M10x35	1
142	JWBS18B-1142	Lower Blade Guide Assembly		1
143	JWBS15-1138	Trunnion Support Bracket Assembly		1
144	TS-1550061	Flat Washer	M8	4
145	TS-2361081	Spring Washer	M8	4
146	TS-1490041	Hex Cap Screw	M8x25	4
147	JWBS18B-1147	Bushing		1
148	TS-1550071	Flat Washer	M10	1
149	TS-1490021	Hex Cap Screw	M8x16	1

13.3.1 JWBS-15/18/20 Trunnion Support Bracket Assembly – Exploded View

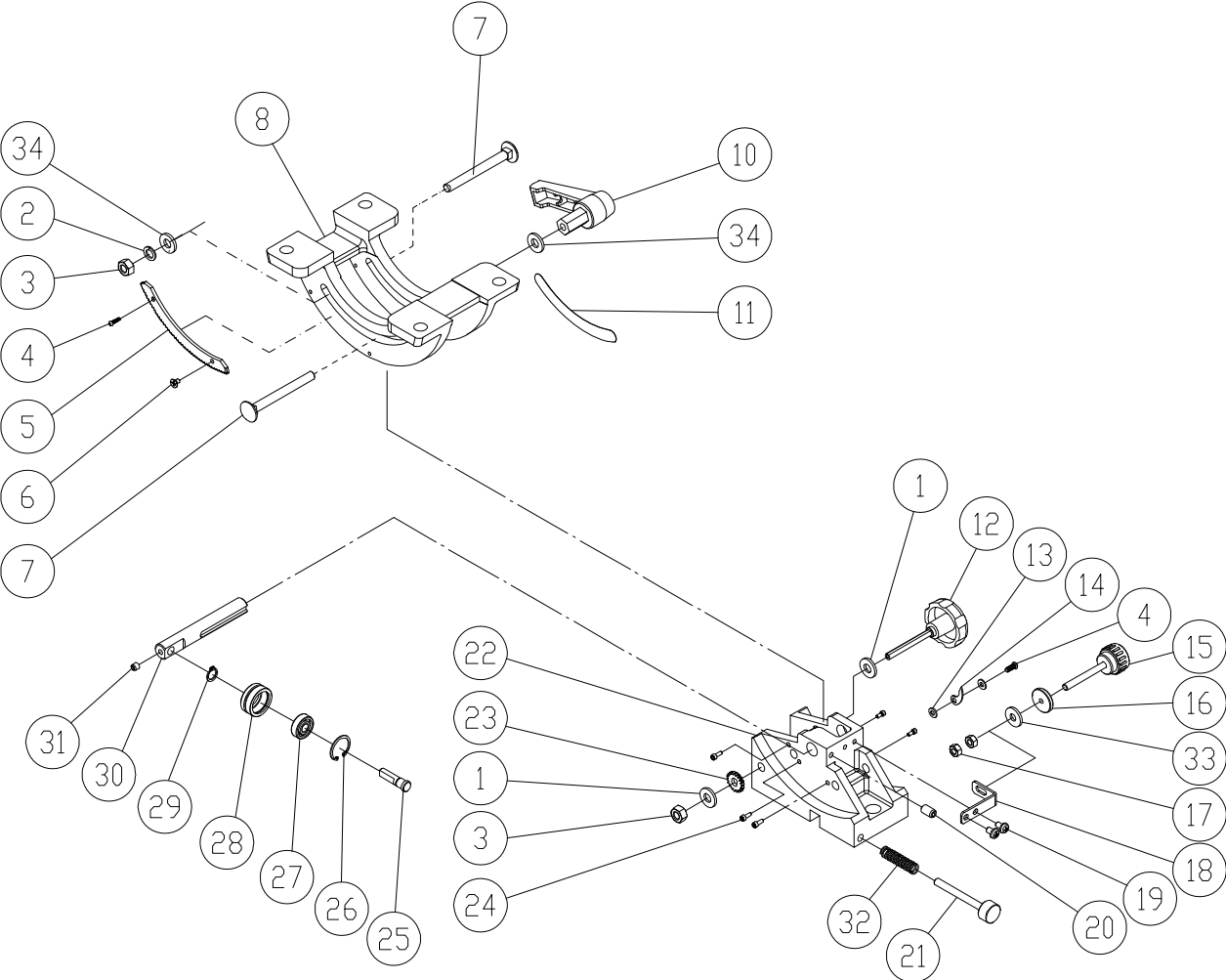

13.3.2 JWBS-15/18/20 Trunnion Support Bracket Assembly – Parts List

Index No	Part No	Description	Size	Qty
	JWBS15-1138A	Trunnion Support Bracket Assembly (#1 thru 34)		
1	TS-1550061	Flat Washer	M8 x Ø23	2
2	TS-2361081	Lock Washer	M8	1
3	TS-1541031	Nylon Lock Hex Nut	M8	2
4	TS-2171012	Phillips Pan Head Machine Screw	M4x6	2
5	PM1500-085-05	Gear Rack		1
6	TS-2284061	Phillips Flat Head Machine Screw	M4x6	1
7	JWBS15-1138-307	Carriage Bolt	M8x90	2
8	PM1500-085-08	Trunnion Block		1
10	JWBS15-1138-310	Lock Handle		1
11	PM1500-085-11	Tilt Scale		1
12	PM1500-085-12	Adjustment Knob Bolt		1
13	TS-1550021	Flat Washer	M4 x Ø8	2
14	PM1500-085-14	Angle Pointer		1
15	JWBS15-1138-315	Adjustment Knob Bolt	M6	1
16	PM1500-085-16	Locking Ring		1
17	TS-2311061	Hex Nut	M6	2
18	PM1500-085-18	Adjustment Plate		1
19	5712561	Phillips Pan Head Machine Screw	M5x8	2
20	PM1500-085-20	Set Screw		1
21	PM1500-085-21	Lock Knob		1
22	JWBS15-1138-322	Trunnion Support Bracket		1
23	PM1500-085-23	Gear		1
24	TS-2235061	Socket Head Cap Screw	M5x6	6
25	PM1500-085-25	Adjustment Shaft		1
26	PM1500-085-26	Retaining Ring	R22	1
27	BB-608ZZ	Ball Bearing	608ZZ	1
28	PM1500-085-28	Thrust Bearing Holder		1
29	PM1500-085-29	Retaining Ring	S8	1
30	JWBS15-1138-330	Adjustment Bar		1
31	TS-1523011	Socket Set Screw	M6x6	1
32	JWBS15-1138-332	Spring		1
33	TS-1550041	Flat Washer	M6 x Ø19	1
34	JWBS15-1138-334	Flat Washer	M8 x Ø23x5t	2

13.9.1 JWBS-15/18/20 Miter Gauge Assembly – Exploded View

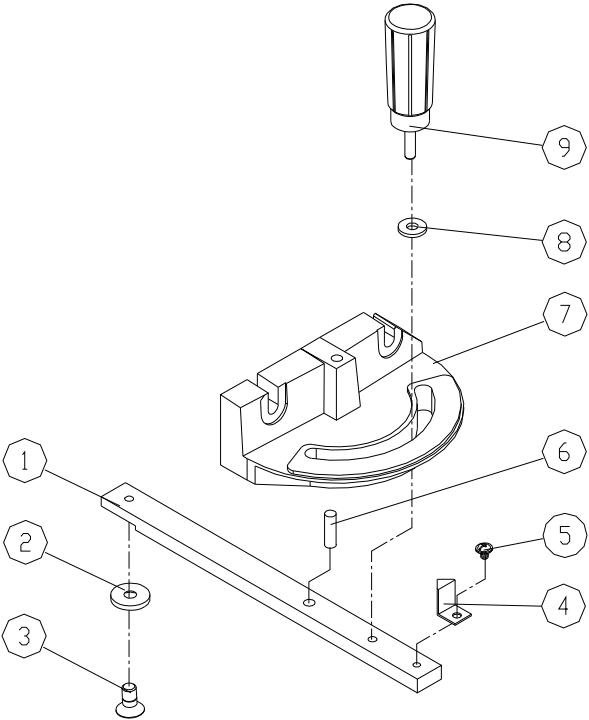

13.9.2 JWBS-15/18/20 Miter Gauge Assembly – Parts List

Index No	Part No	Description	Size	Qty
.....	JWBS15-1122.....	Miter Gauge Assembly (#1 thru 9).....		
1	JWBS15-1122-701....	Guide Bar.....		1
2	JWBS15-1122-702....	Guide Piece		1
3	JWBS15-1122-703....	Countersunk Bolt	M6x6	1
4	JWBS15-1122-704....	Pointer		1
5	PWBS14-251-5	Pan Head Flanged Screw.....	M5x8	1
6	JWBS15-1122-706....	Steel Pin	Ø6x10mm	1
7	JWBS15-1122-707....	Miter Gauge Body.....		1
8	JWBS15-1122-708....	Nylon Washer		1
9	JWBS15-1122-709....	Handle		1

13.11.1 JWBS-18/20 Rip Fence Assembly – Exploded View

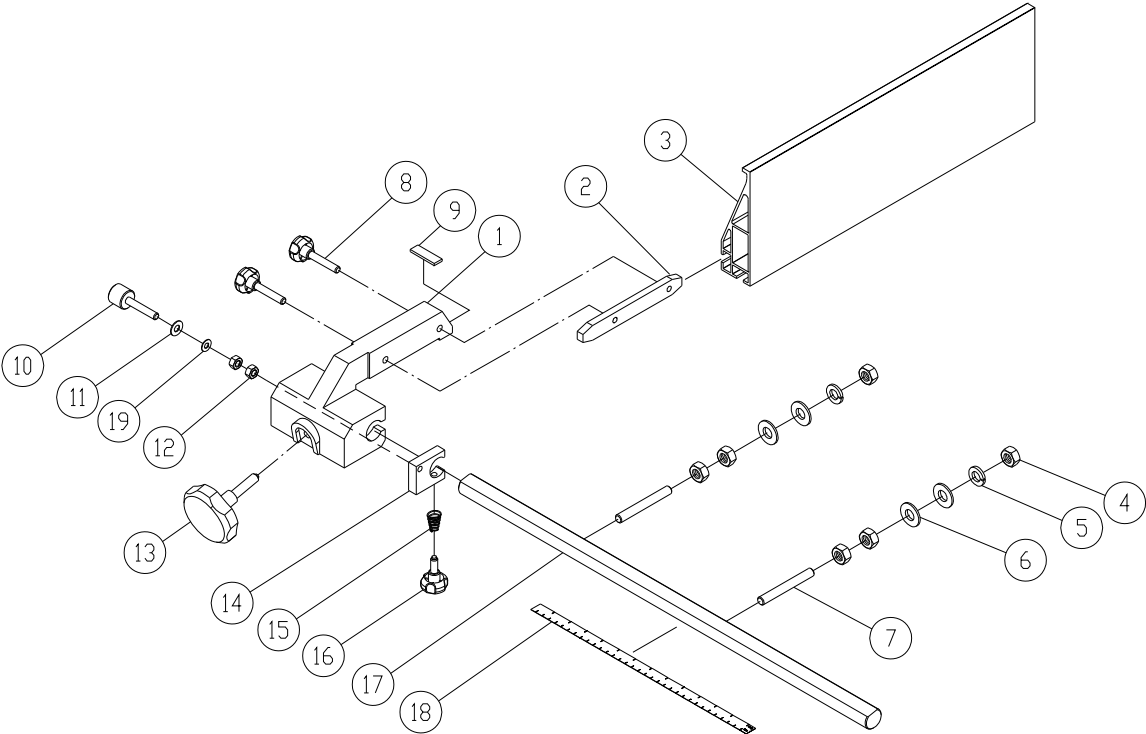

13.11.2 JWBS-18/20 Rip Fence Assembly – Parts List

Index No.	Part No.	Description	Size	Qty
	JWBS18B-1128	Rip Fence Assembly (#1 thru 18)		1
1	JWBS15-1123-201	Fence Body		1
2	JWBS15-1123-202	Lock Block		1
3	JWBS18B-1128-203	Aluminum Fence	572mm	1
4	TS-2311101	Nut	M10	6
5	TS-2361101	Spring Washer	M10	2
6	TS-1550071	Flat Washer	M10	4
7	JWBS15-1123-207	Set Screw	M10x80	2
8	JWBS15-1123-208	Knob	M8x40	2
9	PM1500-107-10	Nylon Pad		1
10	JWBS15-1123-210	Adjustment Knob	M8x50	1
11	JWBS15-1123-211	Fiber Washer		1
12	TS-1540061	Nut	M8	2
13	JWBS15-1123-213	Knob	M8x40	1
14	JWBS15-1123-214	Locate Block		1
15	PM1800B-059-017	Cone Spring		1
16	JWBS15-1123-216	Knob	M6x14	1
17	JWBS18B-1128-217	Fence Guide Rail		1
18	JWBS18B-1128-218	Scale		1
19	JWBS15-1123-219	Wave Washer	Ø8x13 mm	1

13.12.1 JWBS-18/20 Guide Bar Bracket Assembly – Exploded View

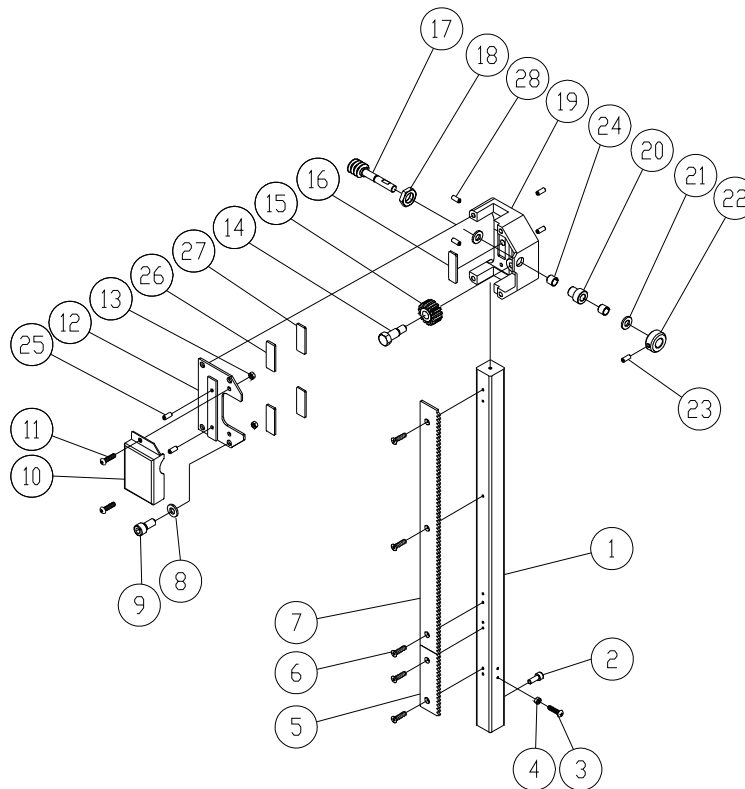

13.12.2 JWBS-18/20 Guide Bar Bracket Assembly – Parts List

Index No	Part No	Description	Size	Qty
	JWBS18B-1125	Guide Bar Bracket Assembly (#1 thru 28)		
1	JWBS18B-1125-401	Guide Bar		1
2	TS-1503021	Socket Head Cap Screw	M6x10	2
3	TS-1532032	Pan Head Screw	M4x10	1
4	TS-1540021	Nut	M4	1
5	PM1500-091-08	Guide Bar Rack (Short)		1
6	TS-2284081	Phillips Flat Head Machine Screw	M4x8	5
7	PM1500-091-20	Guide Bar Rack (Long)		1
8	TS-2361081	Spring Washer	M8	4
9	TS-1504031	Socket Head Cap Screw	M8x16	4
10	PM1500-091-04	Cover		1
11	TS-1534041	Pan Head Screw	M5x10	2
12	JWBS18B-1125-412	Cover		1
13	TS-1540031	Hex Nut	M5	2
14	PM1500-091-10	Fixed Screw		1
15	PM1500-091-11	Gear		1
16	PM1500-091-12	Fixed Plate		1
17	PM1500-091-13	Worm Shaft		1
18	JWBS15-1120-418	Nut		1
19	PM1500-091-15	Guide Bracket		1
20	PM1500-091-18	Bushing		1
21	PM1500-091-25	Fiber Washer		2
22	PM1500-091-19	Collar		1
23	TS-1522011	Set Screw	M5x5	2
24	JWBS15-1120-424	Bushing Bearing	DU 10x12	2
25	TS-1523011	Set Screw	M6x6	2
26	JWBS18B-1125-426	Plate		2
27	JWBS18B-1125-427	Nylon Piece		2
28	JWBS15-1120-425	Plastic Nylon Set Screw	M7x10	4

13.13.1 JWBS-18 Upper Wheel Assembly – Exploded View

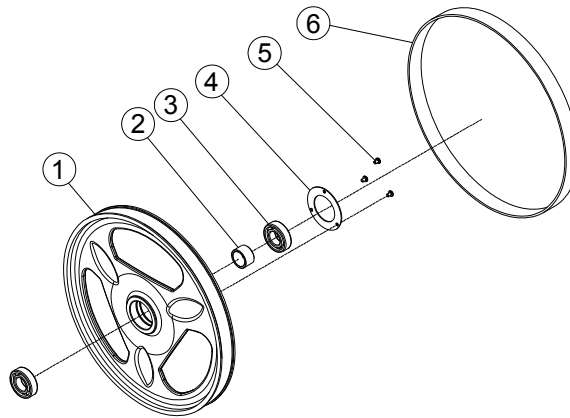

13.13.2 JWBS-18 Upper Wheel Assembly – Parts List

Index No	Part No	Description	Size	Qty
.....	PM1800B-018	Upper Wheel Assembly (#1 thru 6)
1	PM1800B-018-01	Upper Wheel	1
2	PM1800B-018-02	Spacer	1
3	BB-6306LLU	Ball Bearing	6306LLU	2
4	PM1800B-018-04	Bearing Press Plate	1
5	PM1800B-018-05	Phillips Pan Head Machine Screw	M6 x 8	3
6	PM1800B-018-06	Tire	1

13.14.1 JWBS-18 Lower Wheel Assembly – Exploded View

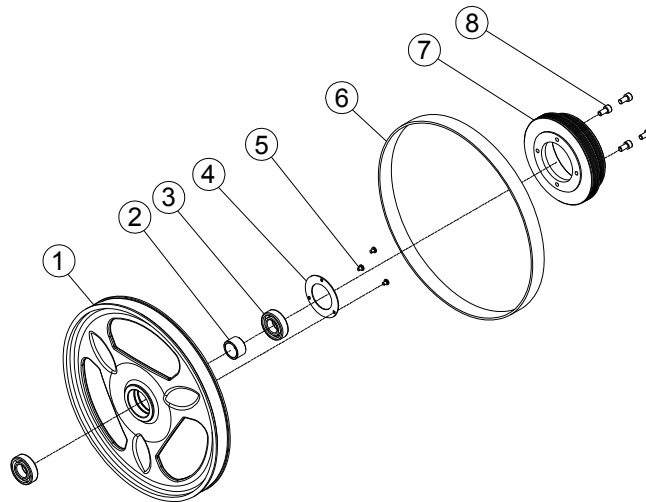

13.14.2 JWBS-18 Lower Wheel Assembly – Parts List

Index No	Part No	Description	Size	Qty
.....	JWBS18B-130	Lower Wheel Assembly (#1 thru 8)
1	PM1800B-022-01	Lower Wheel	18"	1
2	PM1800B-018-02	Bushing	1
3	BB-6306LLU	Ball Bearing	6306LLU	2
4	PM1800B-018-04	Bearing Press Plate	1
5	PM1800B-018-05	Pan Head Bolt	M6x8	3
6	PM1800B-018-06	Tire	PU	1
7	JWBS18B-130-807	Pulley	1
8	TS-1504041	Hex Socket Cap Screw	M8x20	4

13.15.1 JWBS-18/20 Lower Blade Guide Assembly – Exploded View

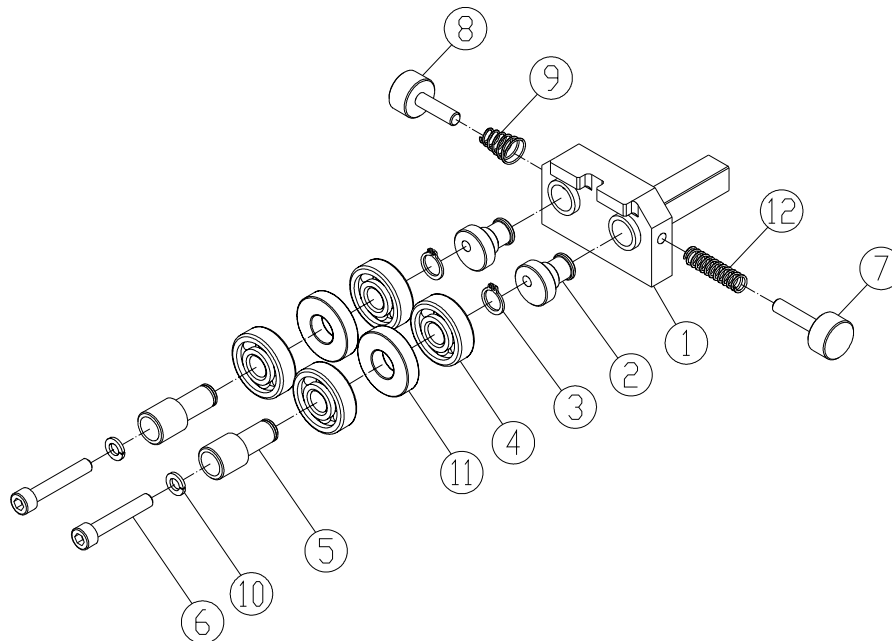

13.15.2 JWBS-18/20 Lower Blade Guide Assembly – Parts List

Index No	Part No	Description	Size	Qty
.....	JWBS18B-1142.....	Lower Blade Guide Assembly (#1 thru 12).....		
1	PM1500-096-01	Lower Blade Guide Support		1
2	PM1500-096-02	Eccentric Shaft		2
3	PM1800B-059-05	Retaining Ring	S15	2
4	BB-6202ZZ	Ball Bearing	6202ZZ	4
5	PM1800B-059-02	Knurled Adjusting Knob		2
6	TS-1503101	Socket Head Cap Screw	M6x45	2
7	PM1500-095-16	Lock Knob		1
8	JWBS15-1137-508	Lock Knob		1
9	PM1800B-059-017	Cone Spring		1
10	TS-2361061	Spring Washer	M6	2
11	PM1800B-059-04	Spacer		2
12	JWBS15-1138-332	Spring		1

13.16.1 JWBS-18/20 Upper Blade Guide Assembly – Exploded View

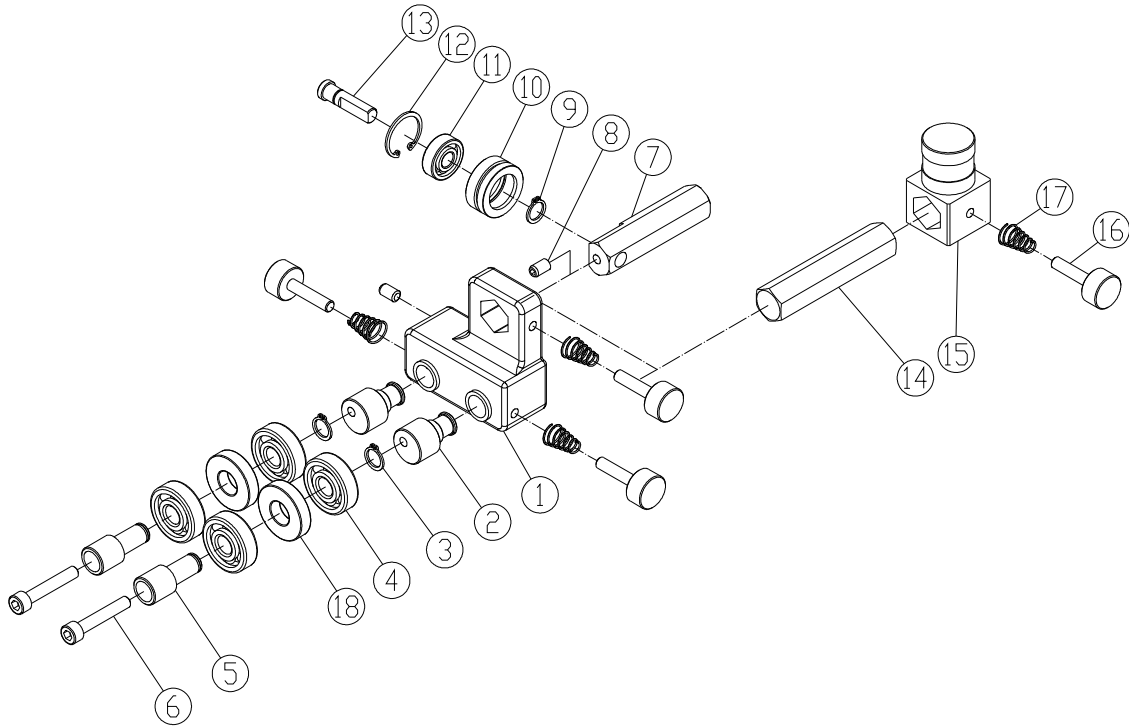

13.16.2 JWBS-18/20 Upper Blade Guide Assembly – Parts List

Index No	Part No	Description	Size	Qty
	JWBS18B-1126	Upper Blade Guide Assembly (#1 thru 18)		
1	PM1500-095-01	Upper Blade Guide Support		1
2	PM1500-095-02	Eccentric Shaft		2
3	PM1800B-059-05	Retaining Ring	S15	2
4	BB-6202ZZ	Ball Bearing	6202ZZ	4
5	PM1800B-059-02	Knurled Knob		2
6	TS-1503101	Socket Head Cap Screw	M6x45	2
7	PM1500-095-07	Spacing Sleeve		1
8	TS-1523011	Set Screw	M6x6	2
9	PM1500-085-29	Retaining Ring	S8	1
10	PM1500-085-28	Thrust Bearing Holder		1
11	JWBS15-1121-611	Ball Bearing	608ZZ	1
12	PM1500-085-26	Retaining Ring	R22	1
13	PM1500-085-25	Adjust Shaft		1
14	PM1500-095-14	Hex Post		1
15	PM1500-095-15	Upper Guide Support Block		1
16	PM1500-095-16	Lock Knob		1
17	PM1800B-059-017	Cone Spring		4
18	PM1800B-059-04	Spacer		2