



# Operating Instructions and Parts Manual

## 15-inch Planer

Models JWP-15B, JWP-15BHH



JWP-15BHH

JWP-15B

**JET**  
427 New Sanford Road  
LaVergne, Tennessee 37086  
Ph.: 800-274-6848  
[www.jettools.com](http://www.jettools.com)

**Part No. M-722150**  
Edition 3 04/2020  
ECR 191210180232  
Copyright © 2019 JET

### 11.1.1 Head Assembly – Exploded View

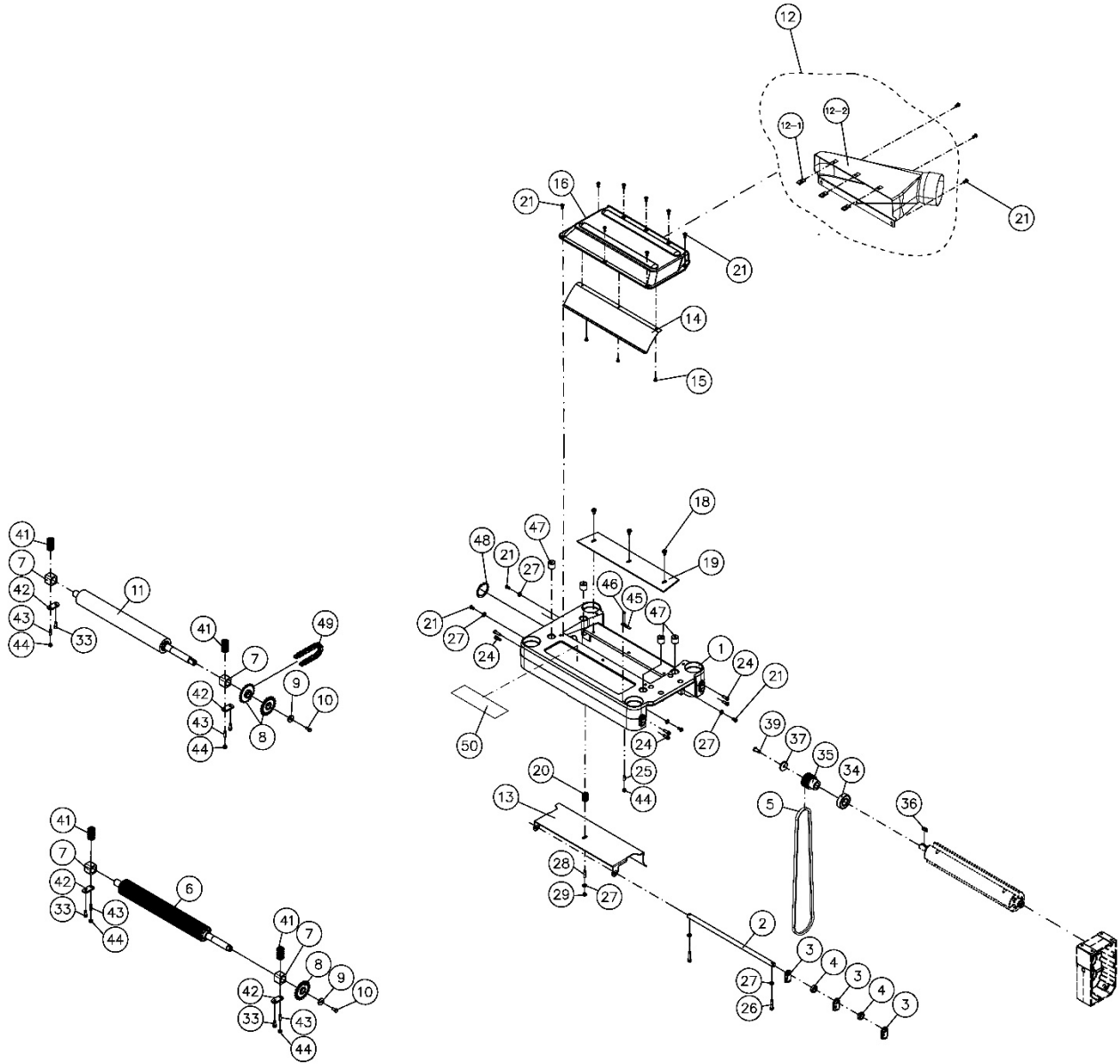

## 11.1.2 Head Assembly – Parts List

Index No	Part No	Description	Size	Qty
1	JWP15B-101	Head		1
2	JWP15B-102	Shaft		1
3	JWP15B-103	Anti-Kickback Finger		37
4	JWP15B-104	Collar		38
5	JWP15B-105	Belt	360J-9	1
6	JWP15B-106	Infeed Roller Assembly		1
7	JWP15B-107	Roller Seat		4
8	JWP15B-108	Sprocket		3
9	JWP15B-109	Flat Washer, special	M6	2
10	TS-1482031	Hex Cap Screw	M6-1.0Px16	3
11	JWP15B-111	Outfeed Roller		1
12	JWP15B-112A	Collector Hood Assembly (#12-1 thru #12-2)		1
12-1	JWP15B-1121A	Collector Hood		1
12-2	JWP15DX-049	Clamp		3
13	JWP15B-113	Front Chipbreaker		1
	JWP15B-116A	Top Cover Assembly (#14 thru #16)		1
14	JWP15B-114	Chip Deflector		1
15	TS-1532042	Machine Screw	M4-1.41Px10	3
16	JWP15B-116	Top Cover		1
18	JWP208-038A	Hex Washer Head Screw	M6-1.0Px12	4
19	JWP15H-040	Deflector Plate		1
20	JWP15B-120	Spring		1
21	TS-2246122	Socket Head Button Screw	M6-1.0Px12	15
24	TS-1503051	Socket Head Cap Screw	M6-1.0Px20	8
25	TS-1482031	Hex Cap Screw	M6-1.0Px16	1
26	TS-1503061	Socket Head Cap Screw	M6-1.0Px25	2
27	TS-1550041	Flat Washer	M6	6
28	TS-1523081	Set Screw	M6-1.0Px30	1
29	TS-1541021	Nylon Lock Hex Nut	M6-1.0P	1
33	TS-1503041	Socket Head Cap Screw	M6-1.0Px16	4
34	BB-6204VV	Ball Bearing	6204-VV	1
35	JWP15B-135	Straight Knife Cutterhead Pulley		1
	JWP15BHH-135	Helical Cutterhead Pulley		1
36	6293356	Key, Dbl Rd Hd (Straight Knife Cutterhead)	6x6x20 mm	1
	JDP17-043R	Key, Dbl Rd Hd (Helical Cutterhead)	6x6x30 mm	1
37	TS-1550061	Flat Washer	M8	1
39	TS-2248202	Socket Head Button Screw	M8-1.25Px20	1
41	JWP15B-141	Spring		4
42	JWP15B-142	Plate		4
43	TS-1523061	Set Screw	M6-1.0Px20	4
44	TS-2311061	Hex Nut	M6-1.0P	5
45	JWP15B-145	Pointer		1
46	5F-H051	Rivet	Φ2x5 mm	2
47	JWP15H-021	Tension Bolt		4
48	F006075	C-Retaining Ring, Int	RTW-47	1
49	JWP15B-149	Chain	#06Bx50P	1
50	LM000369	Warning Label		1
51	LM000370	Lubricating Oil Label (not shown)		2

## 11.2.1 Column Assembly – Exploded View

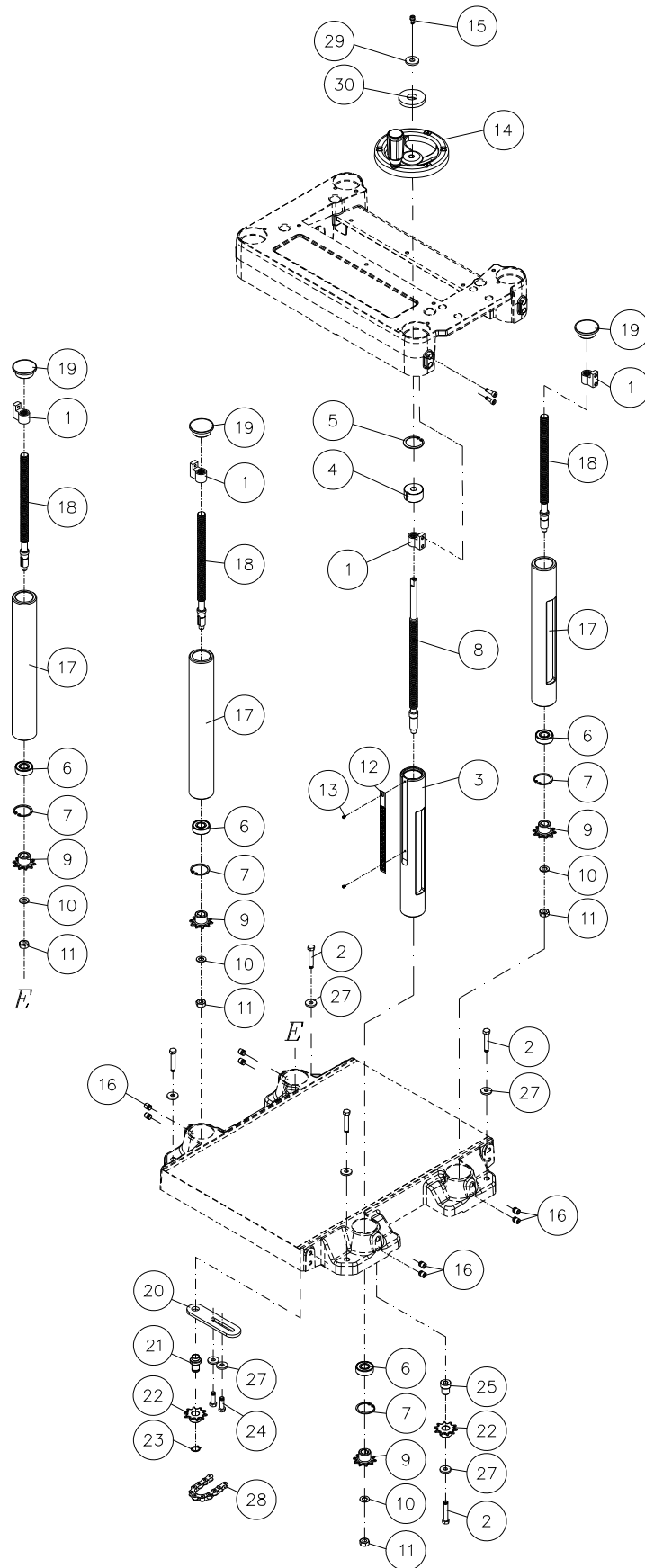

## 11.2.2 Column Assembly – Parts List

Index No	Part No	Description	Size	Qty
1	JWP15B-201	Nut		4
2	TS-1490081	Hex Cap Screw	M8-1.25Px45	5
3	JWP15B-203	Column, Driving		1
4	JWP15B-204	Bushing		1
5	JWP15H-209	C-Retaining Ring, Int	RTW-38	1
6	BB-6202Z	Ball Bearing	6202-Z	4
7	JWP15H-214	C-Retaining Ring, Int	RTW-35	4
8	JWP15B-208	Lead Screw, Driving		1
9	JWP15H-216	Sprocket		4
10	TS-1550071	Flat Washer	M10	4
11	TS-1540071	Hex Nut	M10-1.25P	4
12	JWP15B-212	Cutting Thickness Scale		1
13	F001229	Phillips Pan Hd Machine Screw	M3-0.5Px4	2
14	JPS10TS-SHA	Handwheel Assembly		1
	JPS10TS-168	Handwheel (not shown)		1
	JWTS10-146	Handle (not Shown)		1
	JWTS10-145	Handle Cap (not shown)		1
	JWTS10-147	Shaft (not shown)		1
	F011903	Wave Washer (not shown)	WW-8	1
15	TS-1502031	Socket Head Cap Screw	M5-0.8Px12	1
16	TS-1525021	Set Screw	M10-1.5Px12	8
17	JWP15B-217	Column, Driven		3
18	JWP15H-205	Lead Screw, Driven		3
19	JWP16OS-129	Cap		3
20	JWP15H-221	Bracket		1
21	JWP15H-222	Shaft		1
22	JWP15H-223	Sprocket		2
23	JWP15H-224	C-Retaining Ring, Ext	STW-15	1
24	TS-1490041	Hex Cap Screw	M8-1.25Px25	2
25	JWP15B-225	Sleeve		1
27	TS-1550061	Flat Washer	M8	7
28	JWP16OS-216	Chain	Z410*148P	1
29	TS-2361051	Lock Washer	M5	1
30	LM000371	Direction Label		1

**11.3.1 Cutterhead Assembly – Exploded View**

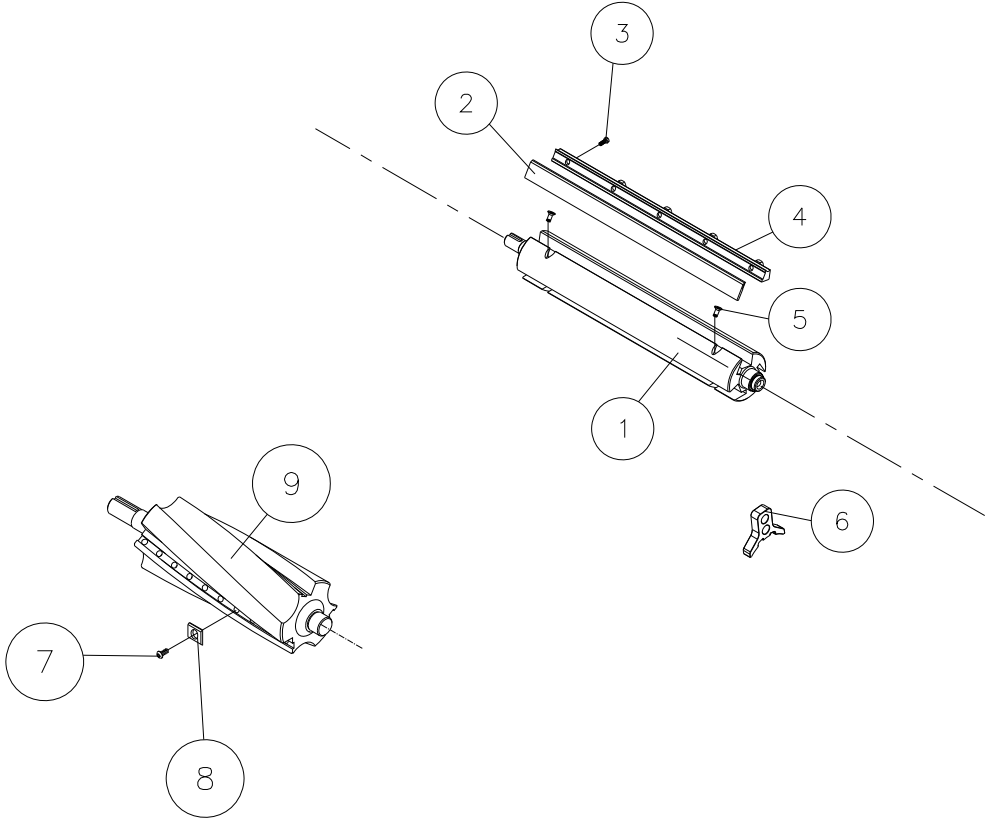

**11.3.2 Cutterhead Assembly – Parts List**

Index No	Part No	Description	Size	Qty
	JWP15B-CA	Straight Knife Cutterhead Assembly (#1 thru #5)		1
1	JWP15B-301	Straight Knife Cutterhead	15"	1
2	708807	Straight Knife		1
3	JWP15B-303	Square Head Screw		15
4	JWP15B-304	Knife Gib		3
5	JWP15B-305	Adjust Screw	M5-0.8Px12	6
6	JWP15B-306	Knife Gauge, Straight Knife Cutterhead		1
	JWP15BHH-CA	Helical Cutterhead Assembly (#7 thru #9)	15"	1
7	JWP208HH-111	Knife Insert Screw	#10-32NFx1/2"	48
8	1791212	Knife Insert (sold in set of 10)	15x15x2.5t mm	
9	JWP15BHH-309	Helical Cutterhead		1
10	JJ6HH-113	Star Point Screwdriver (not shown), for helical cutterhead		2
11	JWP15B-311	Torx Point Screwdriver (not shown)	T30	1

11.4.1 Gear Box Assembly – Exploded View

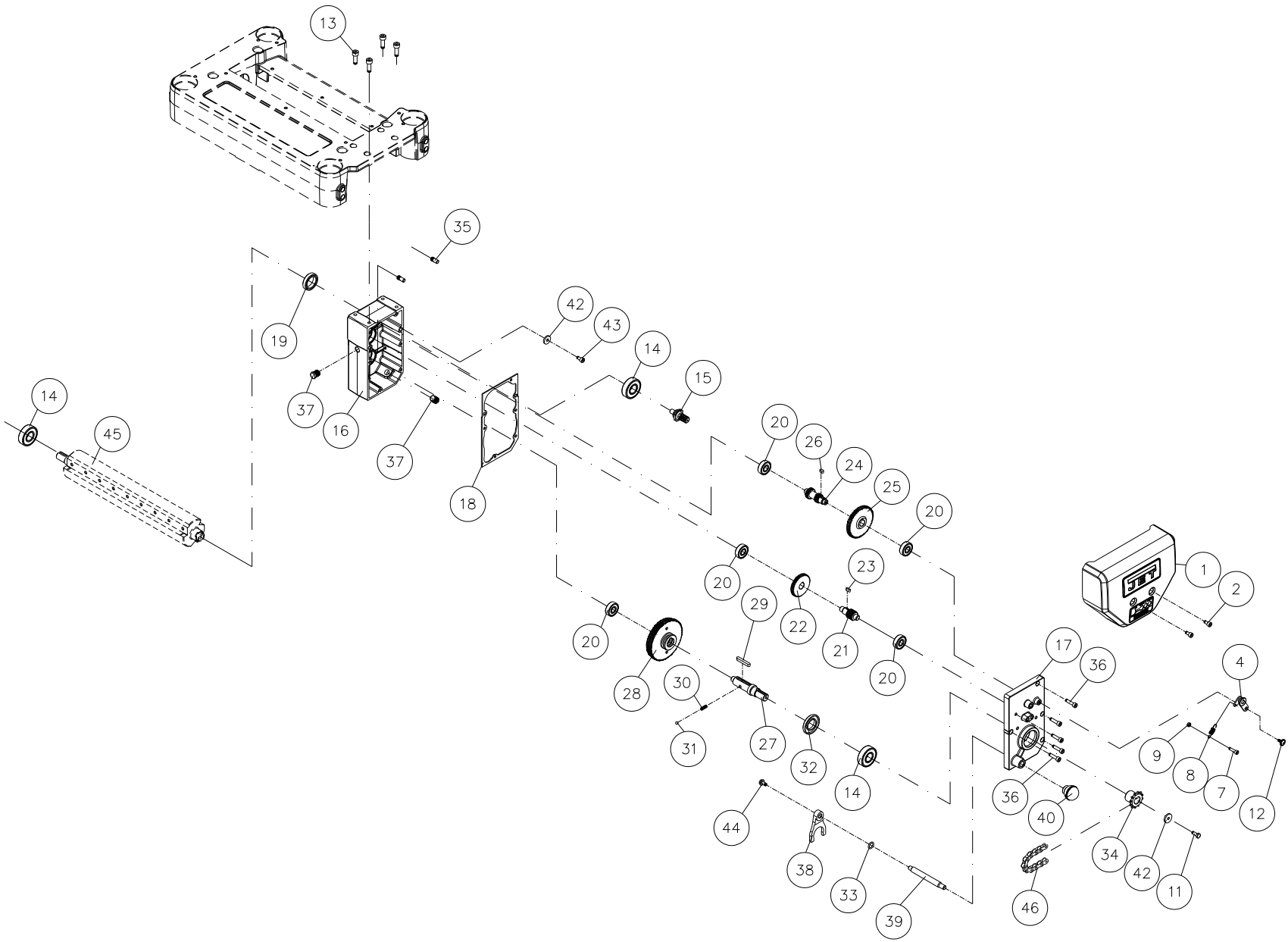

## 11.4.2 Gear Box Assembly – Parts List

Index No	Part No	Description	Size	Qty
1	JWP15B-401	Gear Box Cover		1
2	TS-2246122	Socket Head Button Screw	M6-1.0Px12	2
	JWP15B-GBA	Gear Box with Straight Cutterhead Assembly (#14 thru #45)		
	JWP15BHH-GBA	Gear Box with Helical Cutterhead Assembly (#14 thru #45)		
4	JWP15B-404	Idler Bracket		1
7	TS-1502051	Socket Head Cap Screw	M5-0.8Px20	1
8	PA-C61	Spring		1
9	TS-1540031	Hex Nut	M5-0.8P	1
11	TS-1482031	Hex Cap Screw	M6-1.0Px16	1
12	JWP15B-412	Bolt		1
13	TS-1504051	Socket Head Cap Screw	M8-1.25Px25	4
14	BB-6204VV	Ball Bearing	6204-VV	3
15	JWP15B-415	Gear		1
16	JWP15B-416	Gear Box Casting		1
17	JWP15B-417	Gear Box Cover		1
18	JWP15H-336	Gasket		1
19	6284843	Oil Seal	TC28*40*8	1
20	BB-6201VV	Ball Bearing	6201-VV	5
21	JWP15B-421	Shaft		1
22	JWP15B-422	Gear	52T	1
23	6292768	Key, Dbl Rd Hd	5x5x12 mm	1
24	JWP15H-314	Shaft		1
25	JWP15H-312	Gear		1
26	JWP15H-313	Key	5x5x10 mm	1
27	JWP15H-323	Shaft		1
28	JWP15H-317	Gear Assembly		1
29	JWP15H-320	Key, Dbl Rd Hd	6x6x40 mm	1
30	JWP15H-322	Spring		1
31	SB-6MM	Steel Ball	Φ 6mm	1
32	OS-25476	Oil Seal	SC25*47*6	1
33	JWP15H-333	Oil Seal	P12	1
34	JWP15B-434	Sprocket		1
35	JWP15H-335	Pin		2
36	TS-1503061	Socket Head Cap Screw	M6-1.0Px25	5
37	JWP15H-339	Oil Plug	PT1/4"-19	2
38	JWP15H-329	Clutch		1
39	JWP15H-330	Handle		1
40	JWP15H-334	Knob		1
42	JWP15B-109	Flat Washer	M6	2
43	TS-1503031	Socket Head Cap Screw	M6-1.0PX12	1
44	JWP208-038A	Hex Washer Head Screw	M6-1.0Px12	1
45	JWP15B-CA	Straight Knife Cutterhead Assembly		1
	JWP15BHH-CA	Helical Cutterhead Assembly	15"	1
46	JWP15B-446	Chain	#06B*41P	1



11.5.1 Cabinet Assembly – Exploded View

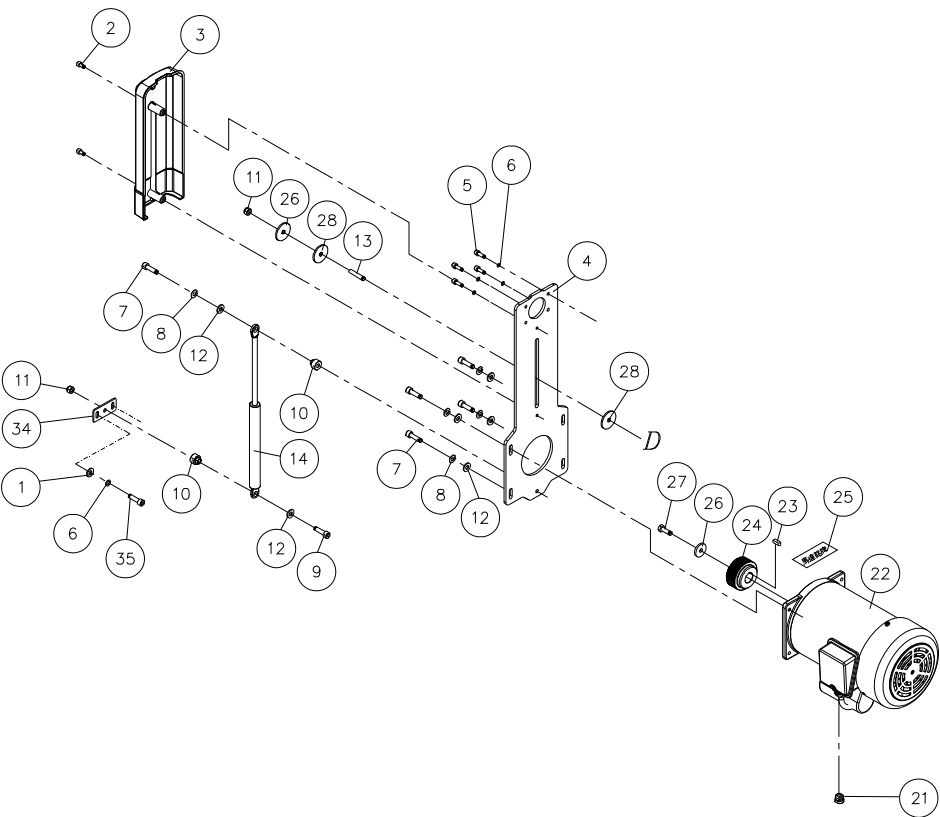
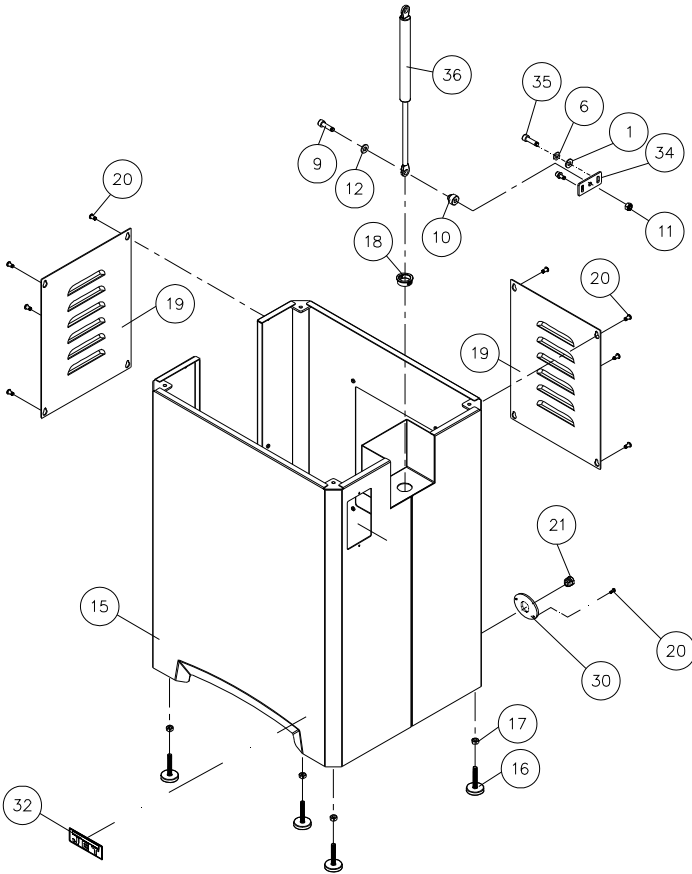

## 11.5.2 Cabinet Assembly – Parts List

Index No	Part No	Description	Size	Qty
1	TS-1550041	Flat Washer	M6	4
2	TS-2246122	Socket Head Button Screw	M6-1.0Px12	2
3	JWP15B-503	Belt Cover		1
4	JWP15B-504	Motor Plate		1
5	TS-1503051	Socket Head Cap Screw	M6-1.0Px20	4
6	TS-2361061	Lock Washer	M6	8
7	TS-1504041	Socket Head Cap Screw	M8-1.25Px20	5
8	TS-2361081	Lock Washer	M8	5
9	TS-1504051	Socket Head Cap Screw	M8-1.25Px25	2
10	JWP15B-510	Sleeve		3
11	TS-1541031	Nylon Lock Hex Nut	M8-1.25P	3
12	TS-1550061	Flat Washer	M8	7
13	JWP15B-513	Set Screw	M8-1.25Px35	1
14	JWP15B-514	Gas Strut	350N	1
15	JWP15B-515	Cabinet		1
16	JPS10TSC-305	Leveler Pad		4
17	TS-1540061	Hex Nut	M8-1.25P	4
18	JWP15B-518	Cable Protector	NB-2430	1
19	JWP15B-519	Door		2
20	TS-2246122	Socket Head Button Screw	M6-1.0Px12	10
21	JWP15B-707	Strain Relief	SB7R-3	2
22	JWP15B-522	Motor (includes #25)	3HP*230V*60HZ	1
	JWP15B-SC	Start Capacitor	300MFD 125VAC	1
	JWP15B-RC	Run Capacitor	60µF 250VAC	1
23	5509069	Key, Dbl Rd Hd	6x6x18mm	1
24	JWP15B-524	Motor Pulley		1
25	LM000372	Motor Label, JWP-15B	3HP*230V*60HZ	1
26	TS-1550061	Flat Washer	M8	2
27	TS-1490031	Hex Cap Screw	M8-1.25Px20	1
28	JWP15B-528	Plastic Washer		2
30	JWP15B-713	Plate		1
32	JET-92	JET Logo	92x38mm	1
33	15S-278	Belt Cover Warning Label (not shown)		1
34	JWP15B-534	Adjustable Bracket		2
35	TS-1503041	Socket Head Cap Screw	M6-1.0Px16	4
36	JWP15B-536	Gas Strut	200N	1
37	LM000373	ID label, Straight CH		1
	LM000374	ID label, Helical CH		1

**11.6.1 Extension Table – Exploded View**

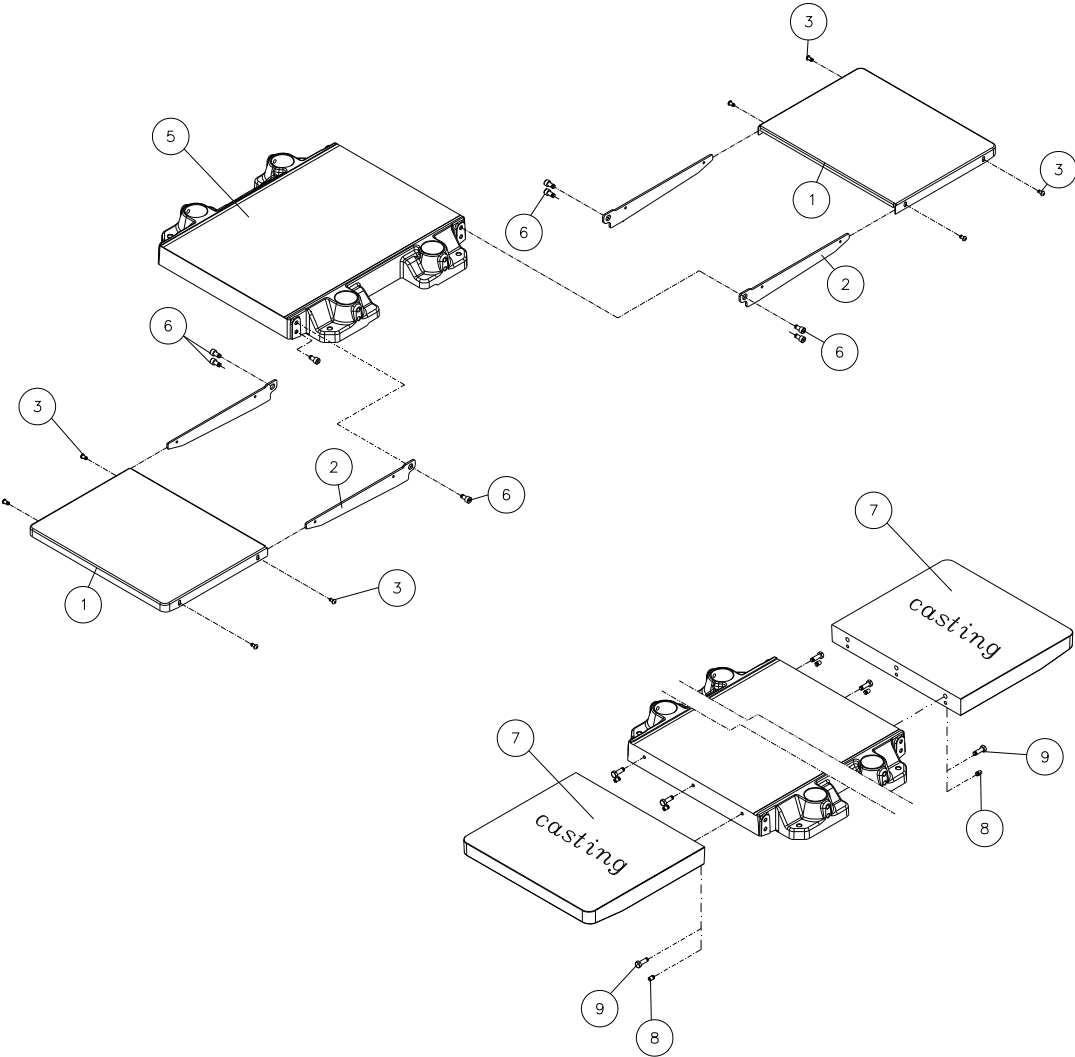

**11.6.2 Extension Table, Sheet Metal – Parts List**

Index No	Part No	Description	Size	Qty
	JWP15B-SETA.....	Steel Extension Table Assembly (#1 thru #3)		
1	JWP15B-601	Steel Extension Table		2
2	JWP15B-602	Support		4
3	JWP15B-603	Torx Head Screw	M6-1.0Px12	8
5	JWP15B-605	Main Table		1
6	TS-1504031	Socket Head Cap Screw	M8-1.25Px16	8
	TS-152707	Allen Wrench (not shown)	6mm	1

**11.6.3 Extension Table, Cast Iron – Parts List**

Index No	Part No	Description	Size	Qty
	JWP15BHH-CETA ....	Cast Iron Extension Table Assembly (#7 thru #9)		
7	JWP15BHH-607	Cast Iron Extension Table		2
8	TS-1524051	Set Screw	M8-1.25Px20	6
9	TS-1490041	Hex Cap Screw	M8-1.25Px25	6

### 11.7.1 Switch Assembly – Exploded View

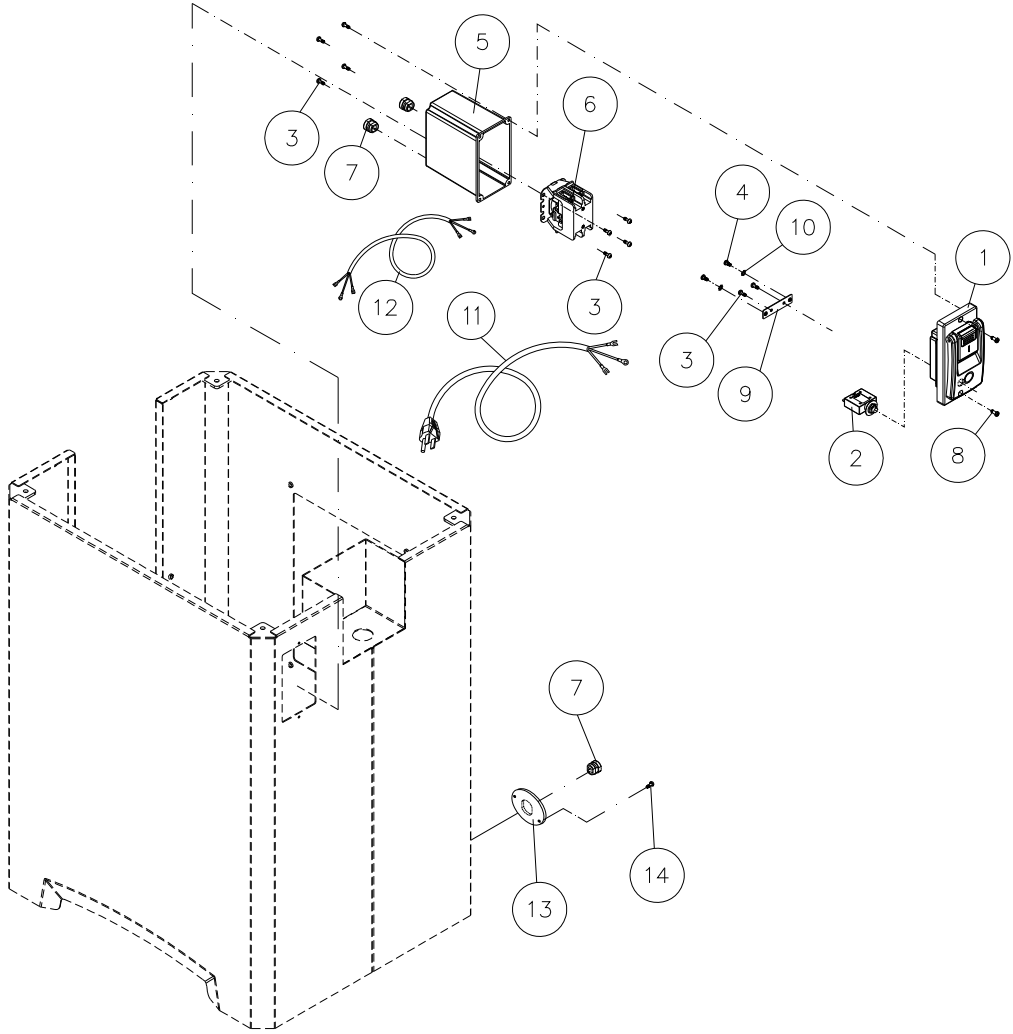

### 11.7.2 Switch Assembly – Parts List

Index No	Part No	Description	Size	Qty
	JWP15B-SA	Switch Assembly (#1 thru #13)		1
1	JWP15B-701	Control Panel Kit		1
	JWP15B-SK	Safety Key (not shown)		1
2	JWP15B-702	Overload Protector	14A	1
3	JWP15B-703	Machine Screw	M4-1.41Px10	10
4	TS-2284082	Phillips Pan Hd Machine Screw	M4-0.7Px8	2
5	JWP15B-705	Switch Box		1
6	JWP15B-706	Contactor		1
7	JWP15B-707	Strain Relief	SB7R-3	3
8	TS-1532032	Phillips Pan Hd Machine Screw	M4-0.7Px10	2
9	JWP15B-709	Grounding Plate		1
10	F001995	Ext Tooth Lock Washer	#8 (M4)	2
11	JWP15B-711	Power Cable	14AWG*3C*3100mm	1
12	JWP15B-712	Motor Cable	14AWG*3C*850mm	1
13	JWP15B-713	Plate		1
14	TS-2246122	Socket Head Button Screw	M6-1.0Px12	2