

. - F 013 810 000 - 8100www.powertools-aftersaleservice.com**BOSCH**

Item	Part Number	Description	Illustration	Price	Quantity	Price Group
2	2 610 021 277	Motor		1	-,-	1 30
4	2 610 019 169	Electronic Assembly		1	-,-	1 35
22	2 607 336 987	Battery Pack 7.2V 1.5Ah Li		1	-,-	1 35
23	2 610 013 854	Nose		1	-,-	1 13
24	2 610 013 397	Screw		1	-,-	5 10
25	2 609 110 537	Clip		1	-,-	1 11
27	2 610 005 472	Spring Cap		1	-,-	1 10
28	2 610 014 582	Nut		1	-,-	1 12
29	2 615 110 480	Collet 1/8"		1	-,-	1 15
31	2 610 021 279	Anti-Twist Lock		1	-,-	1 11
650	2 610 930 692	Chuck Wrench		1	-,-	1 13
653	2 607 225 633	Charger USA 120V		1	-,-	1 38
801	2 610 022 233	Housing Assembly		1	-,-	1 28

Illustration - Type E

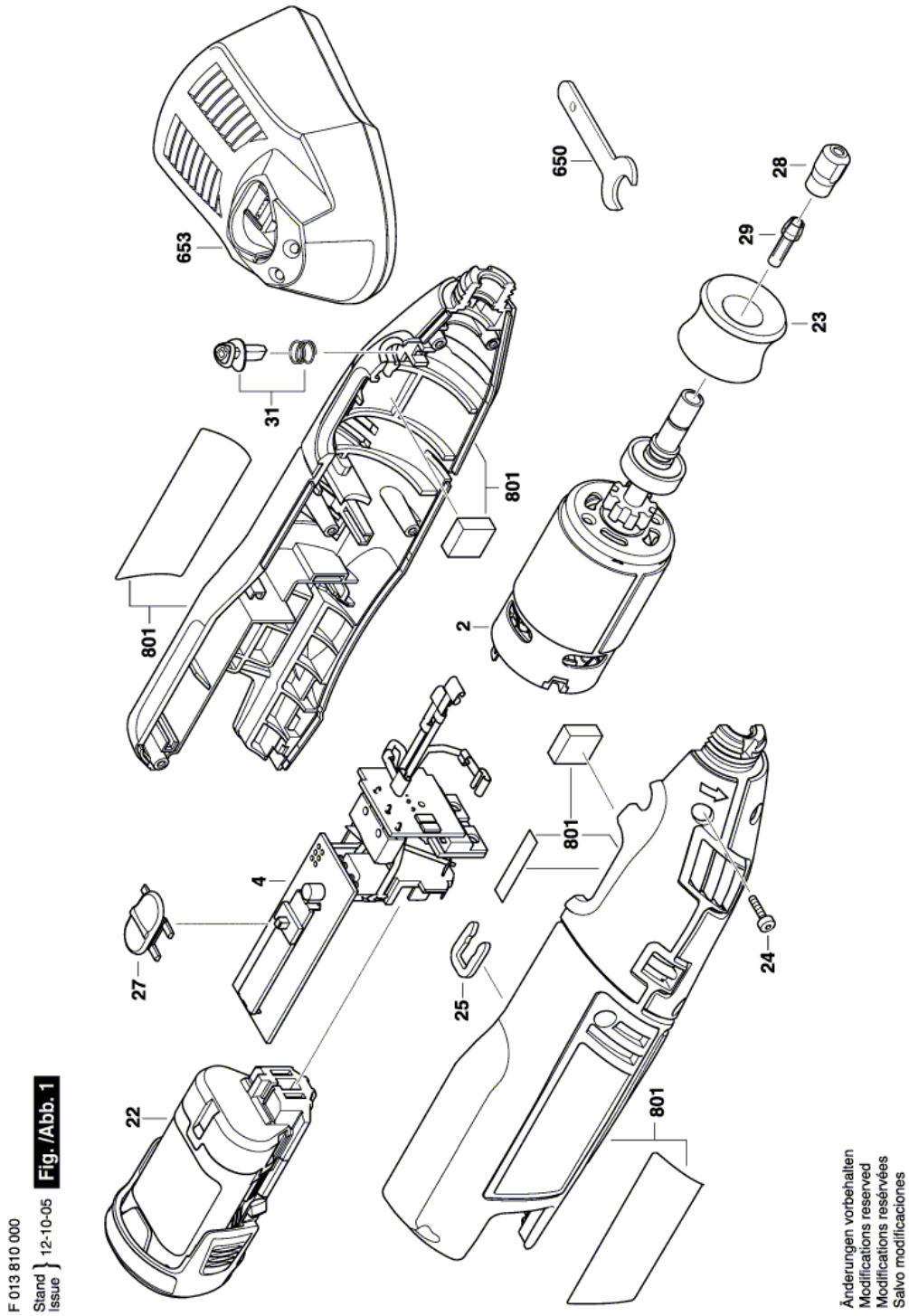

F 013 810 000
Stand } 12-10-05
Issue } **Fig. /Abb. 1**

Information subject to change without further notice.