

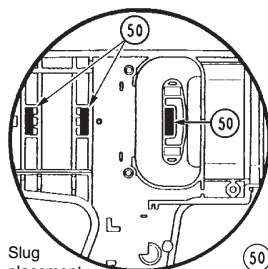

SERVICE PARTS LIST

BULLETIN NO.
55-26-1815

SPECIFY CATALOG NO. AND SERIAL NO. WHEN ORDERING PARTS		REVISED BULLETIN	DATE
3/4" D.I. IMPACT WRENCH - 220/240V Argentina			Dec. 2012
CATALOG NO. 9075-59A	STARTING SERIAL NO. E97A	WIRING INSTRUCTION See Page Two	



Slug placement is for both handle halves.

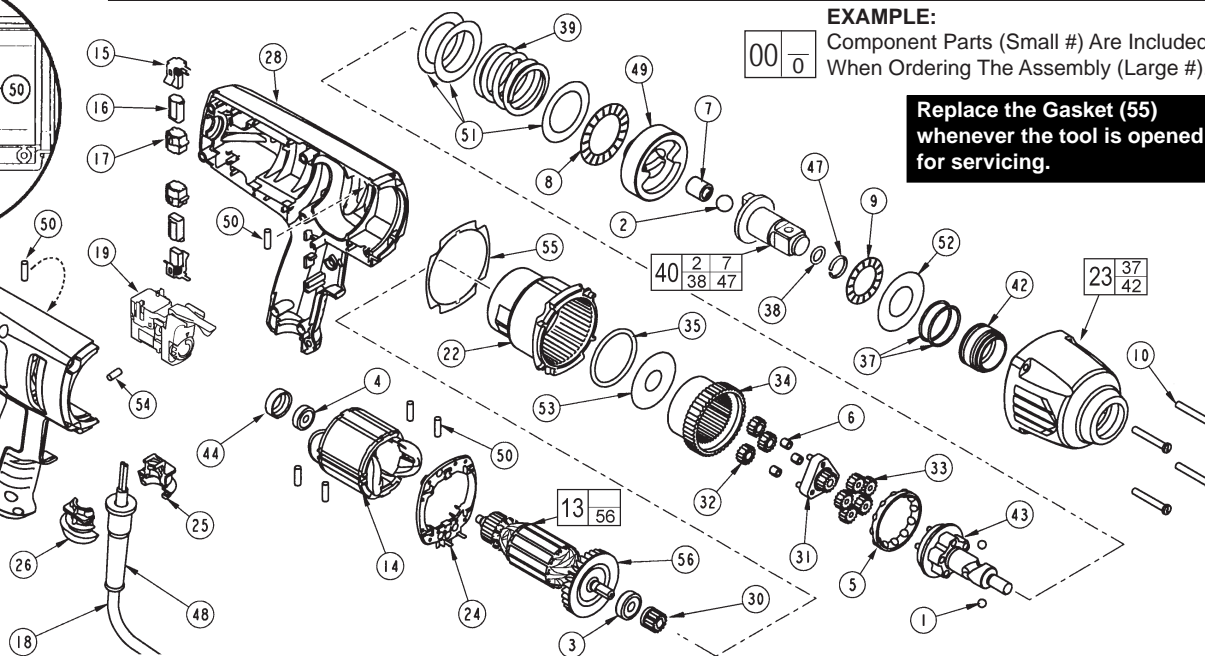

EXAMPLE:
Component Parts (Small #) Are Included When Ordering The Assembly (Large #).

Replace the Gasket (55) whenever the tool is opened for servicing.

FIG.	PART NO.	DESCRIPTION OF PART	NO.REQ.
1	02-02-0250	1/4" Ball	(2)
2	-----	1/2" Ball	(1)
3	02-04-0852	Ball Bearing	(1)
4	02-04-0645	Ball Bearing	(1)
5	02-40-0050	Angular Contact Bearing	(1)
6	02-50-3250	Unit Cage Bearing	(3)
7	-----	Drawn Cup Bearing	(1)
8	02-80-0200	Thrust Bearing	(1)
9	02-80-3256	Thrust Bearing	(1)
10	05-88-5988	K50 x 35mm Screw	(4)
11	06-95-6290	M5 x 2.24 x 18 Plastite Screw	(6)
12	-----	Service Nameplate	(1)
13	16-14-2220	Armature	(1)
14	18-04-2210	Field	(1)
15	22-18-0040	Brush Assembly	(2)
16	22-20-0110	Brush Tube	(2)
17	22-20-0465	Brush Tube Holder	(2)
18	22-64-5264	Cord	(1)
19	23-66-2775	Switch	(1)
22	28-14-0175	Gearcase	(1)
23	14-38-0100	Front Housing Assembly	(1)
24	31-15-2045	Field Connector	(1)
25	31-17-0261	Cord Clamp	(1)
26	31-17-0271	Cord Clamp	(1)
27	31-44-2176	Right Handle	(1)
28	31-44-2181	Left Handle	(1)
30	32-60-0150	Sun Gear	(1)
31	32-60-0175	Sun Gear	(1)
32	32-62-0200	Planet Gear	(3)
33	32-62-0215	Planet Gear	(5)
34	32-65-0005	Ring Gear	(1)
35	34-40-0070	O-Ring	(1)
37	-----	O-Ring	(2)
38	34-40-1210	O-Ring	(1)
39	40-50-0241	Spring	(1)
40	14-73-0156	Anvil Assembly	(1)
42	-----	Bushing	(1)
43	14-73-0300	Cam Shaft Assembly	(1)
44	42-96-0015	Bearing Cup	(1)
47	44-90-4540	Friction Ring	(1)
48	44-76-0210	Cord Protector	(1)
49	44-82-0210	Ram	(1)
50	45-30-0025	Rubber Slug	(6)

FIG.	PART NO.	DESCRIPTION OF PART	NO.REQ.
51	45-88-0535	Washer	(3)
52	45-88-1575	Washer	(1)
53	45-88-3250	Washer	(1)
54	45-30-0021	Slug	(1)
55	43-44-0991	Gasket	(1)
56	22-84-0375	Fan	(1)
57	23-94-0275	Wire Assembly (See page two)	(1)
58	23-94-0276	Wire Assembly (See page two)	(1)

FIG. 4 NOTES:
Orient bearing seal (black side) toward the commutator.

10 Torque to 45-50 in./lbs.

11 Torque to 25-30 in./lbs.

16 At the time of brush replacement, the tool should be relubricated with Type "J" Grease, No.49-08-4220.

FIG. 23,34,42, 43,49 LUBRICATION (Type "J" Grease, No.49-08-4220):
Lightly coat with grease the Ring Gear (34) and the bearing races of the Camshaft Planet Carrier (43), the back bearing surface of the Ram (49) and the I.D. the Front Housing Bushing (42).

7,40 Place a dab of grease in the Needle Bearing (7) inside the Anvil (40).

31,32,33,43 Fill with grease the center of the five Planet Gears (33) on the Camshaft Assembly (43). Fill the center of the three Planet Gears (32) on the Sun Gear (31).

49 Place approximately 1/2 oz. of grease in the front cavity of the Ram.

43 Place approximately 1/2 oz. grease on the Camshaft (43) inside the Spring (39).

WIRING INSTRUCTIONS

TITLE

IMPACT WRENCH

BULLETIN

MILWAUKEE ELECTRIC TOOL CORP. 13135 WEST LISBON RD. BROOKFIELD, WIS.

DATE

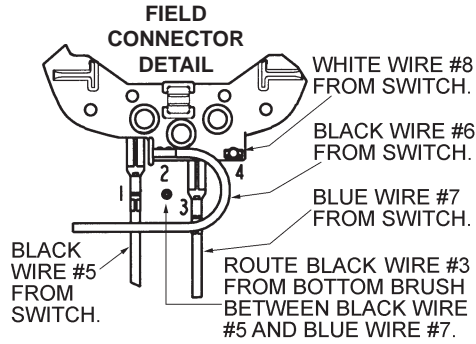
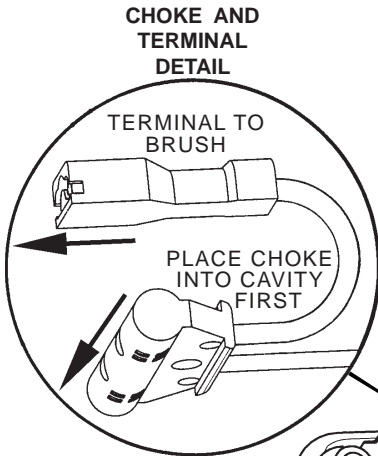

TORQUE SWITCH SCREWS TO 4-6 IN.-LBS.

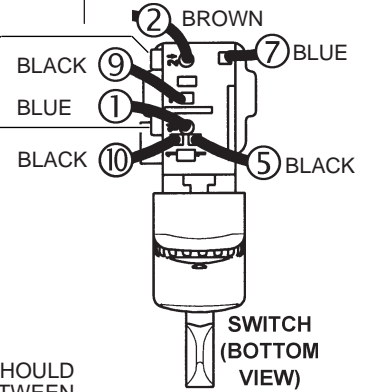

TUCK ALL EXCESS LEAD WIRE FROM #3 AND #4 INTO AREA BETWEEN TRAPS, AS SHOWN.

NOTE:
Models 9075-59 and 9075-59A come with a power cord. Disregard the blade housing assembly. Also disregard the suppressor.

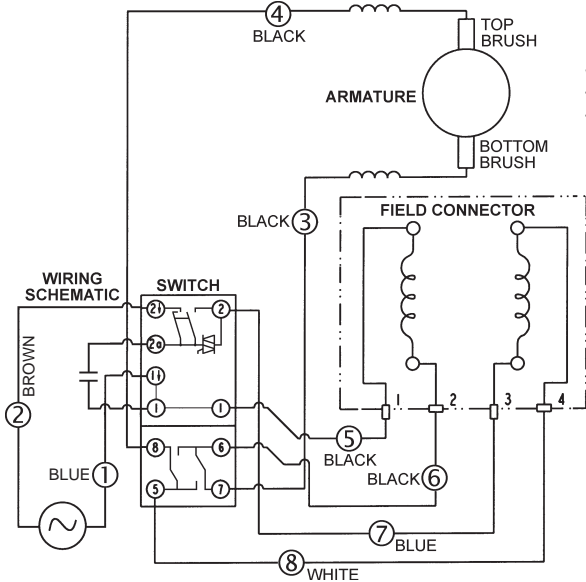
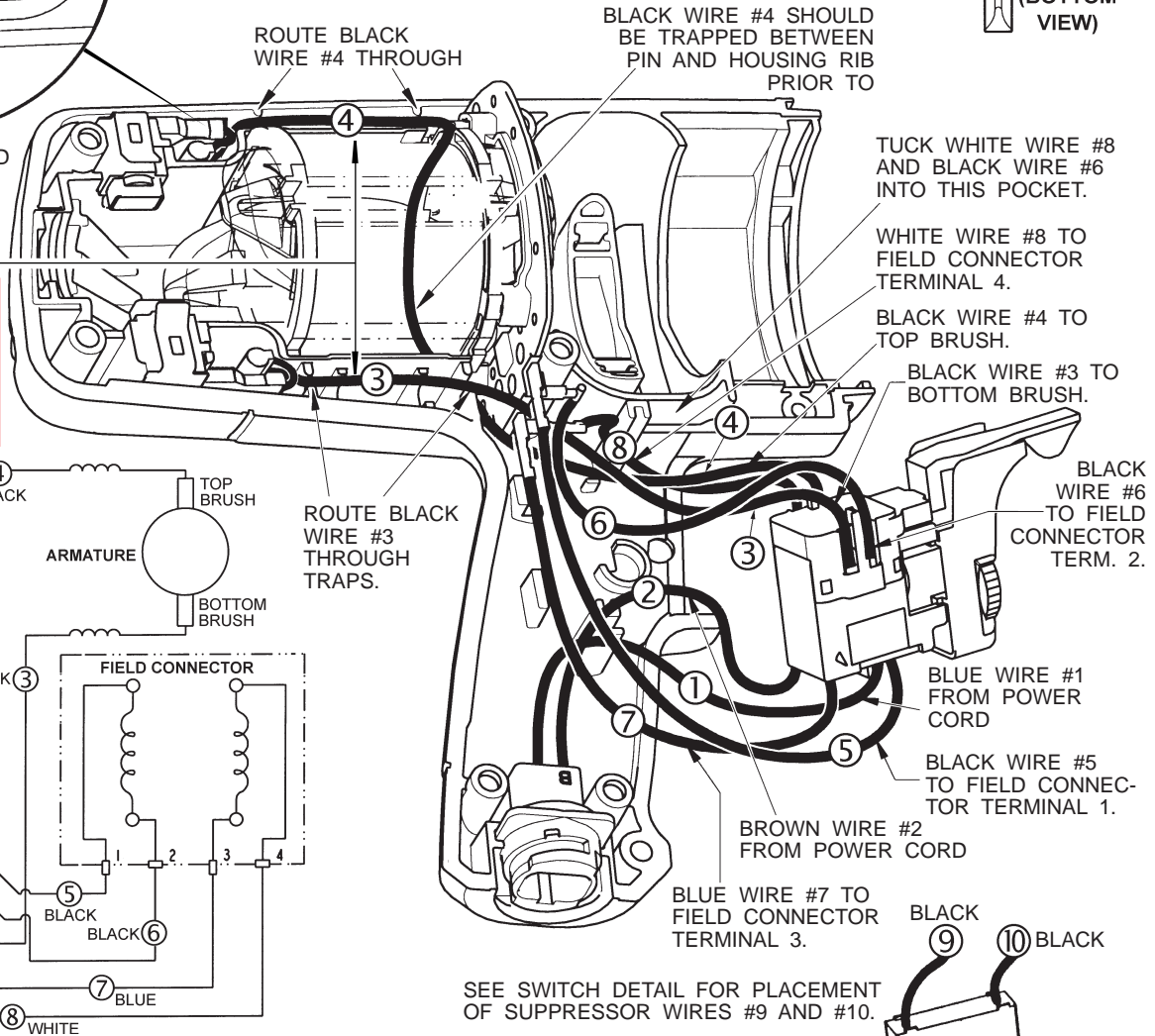

SEE SWITCH DETAIL FOR PLACEMENT OF SUPPRESSOR WIRES #9 AND #10.

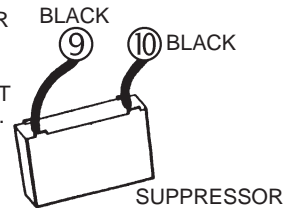

WIRING SPECIFICATIONS

Wire No.	Wire Color	Origin or Part No.	Gauge	Length	Terminals, Connectors and End Wire Preparation
1	Blue	Power Cord	16	2.85	Component of the blade hsg. assy. or power cord.
2	Brown	Power Cord	16	2.75	Component of the blade hsg. assy. or power cord.
3	Black	23-94-0275	18	-----	Component of 23-94-0275 leadwire assembly.
4	Black	23-94-0276	18	-----	Component of 23-94-0276 leadwire assembly.
5	Black	23-94-0250	18	4.75	Strip .188 for T1. Strip .32 and tin.
6	Black	23-94-0240	18	2.75	Strip .188 for T2 and T3.
7	Blue	23-94-0245	18	4.75	Strip .188 for T1. Strip .32 and tin.
8	White	23-94-0255	18	2.90	Strip .188 for T1 and T2.
9	Black	Suppressor	-----	-----	Component of suppressor assembly.
10	Black	Suppressor	-----	-----	Component of suppressor assembly.

BULK LEAD WIRE - BULLETIN 58-01-0003

NOTE:

All lead lengths are before stripping. All leads must be held to ± .125" unless specified elsewhere.

TERMINAL DESCRIPTION		
Code	Part No.	Qty.
T1	23-74-0010	3
T2	23-74-1060	4
T3	23-74-1100	1