



SERVICE PARTS LIST

BULLETIN NO.
54-02-0600

SPECIFY CATALOG NO. AND SERIAL NO. WHEN ORDERING PARTS		REVISED BULLETIN	DATE
3/4 TON LEVER HOIST			Oct. '86
CATALOG NO. 9530, 9531, 9532	DATE CODE 4-86	WIRING INSTRUCTION NONE	

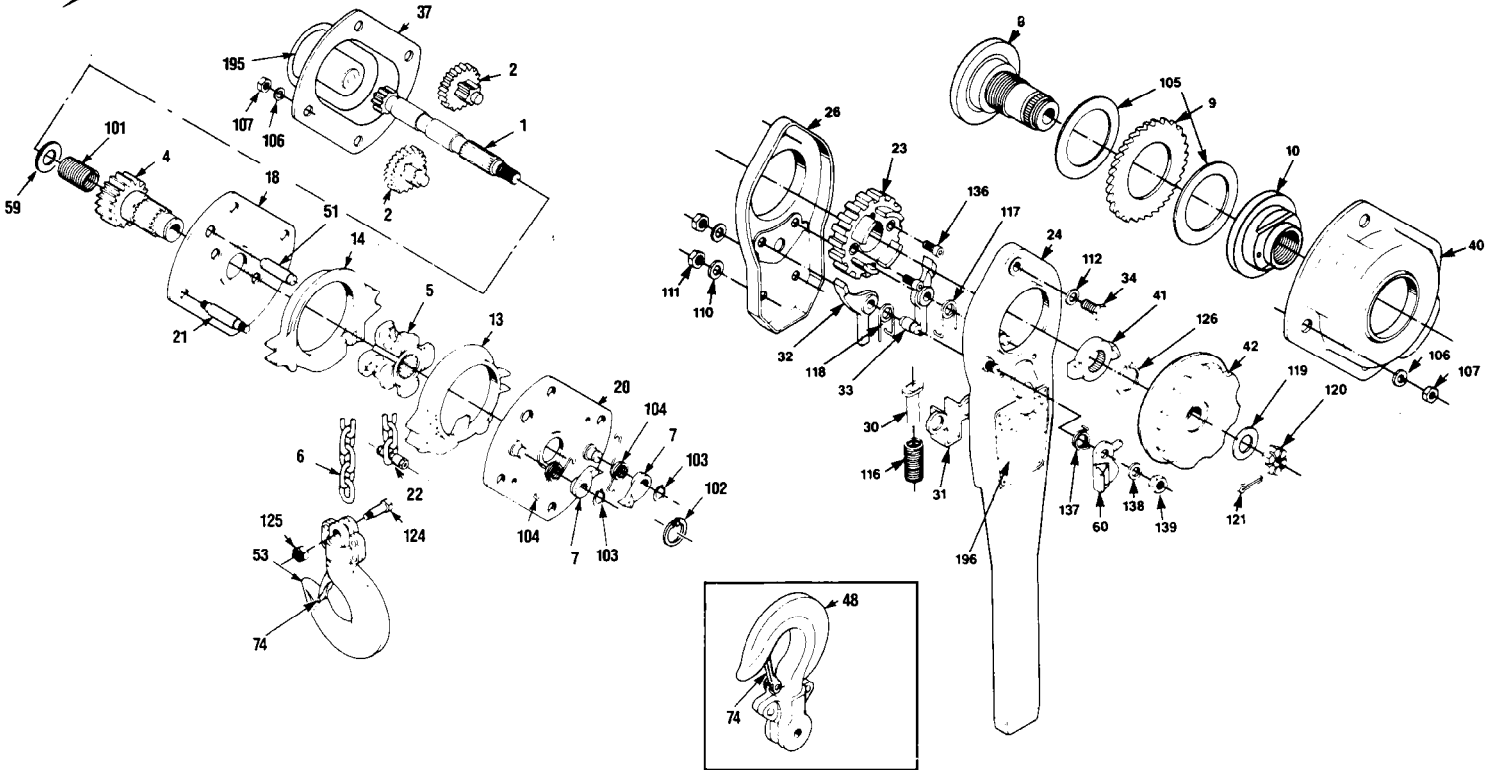

FIG.	PART NO.	DESCRIPTION OF PART	NO. REQ.
1	14-47-0460	Pinion Shaft (Incl. Fig. 59, 101)	(1)
2	32-60-2275	Pinion Gear	(2)
4	14-47-0210	Output Gear Kit (Incl. Fig. 102)	(1)
5	45-11-0060	Load Sheave	(1)
7	14-47-0290	Pawl Kit (Incl. Fig. 9, 103)	(1)
8	43-78-0365	Disc Hub	(1)
10	45-88-8055	Disc Nut Washer	(1)
13	14-47-0490	Chain Guide Kit (Incl. Fig. 14)	(1)
18	44-66-5620	Gear Side Plate	(1)
20	44-66-5635	Handle Side Plate	(1)
21	14-47-0540	Stay Bolt Kit (Incl. Fig. 106, 107)	(4)
22	45-52-2040	Stop	(1)
23	14-47-0390	Disc Nut Kit (Incl. Fig. 136)	(1)
24	14-47-0420	Operating Handle Kit (Incl. Fig. No. 26, 110, 111, 112, 196, 34)	(1)
31	14-47-0400	Spring Shaft Kit (Incl. Fig. 30, 116)	(1)
33	14-47-0380	Handle Pawl Kit (Incl. Fig. 32, 117, 118)	(1)
37	42-92-0625	Gear Cover	(1)
40	42-92-0640	Ratchet Cover	(1)
41	14-47-0350	Parts Kit (Incl. Fig. 119, 120, 121, 126)	(1)
42	43-98-0325	Free Chain Knob	(1)
48	14-36-0060	Top Hook Assembly (Incl. Fig. 74)	(1)
51	44-60-0950	Yoke Pin	(1)
53	14-36-0100	Bottom Hook Assembly (Incl. Fig. 74, 124, 125)	(1)
60	14-47-0410	Free Chain Lever Kit (Incl. Fig. 137, 138, 139)	(1)
74	14-47-0240	Latch Kit	(2)
105	14-47-0320	Brake Kit (Incl. Fig. 103, 104)	(1)
124	14-03-0060	Chain Fastening Bolt Assembly (Incl. Fig. 125)	(1)
195	10-37-0010	Caution Label	(1)

FIG.	PART NO.	DESCRIPTION OF PART	NO. REQ.
		(For Catalog No. 9530)	
196	12-40-0080	Nameplate	(1)
6	42-60-0280	3/4 Ton 5 Ft. Lift Chain	(1)
		(For Catalog No. 9531)	
196	12-40-0085	Nameplate	(1)
6	42-60-0285	3/4 Ton 10 Ft. Lift Chain	(1)
		(For Catalog No. 9532 Only)	
196	12-40-0090	Nameplate	(1)
6	42-60-0290	3/4 Ton 20 Ft. Lift Chain	(1)