

**CRAFTSMAN 3/8 in. 15.6 VOLT CORDLESS DRILL-DRIVER
MODEL NUMBER 973.114250**

The model number will be found on a label attached to the motor housing. Always mention the model number in all correspondence regarding your 3/8 in. **CORDLESS DRILL-DRIVER** or when ordering repair parts.

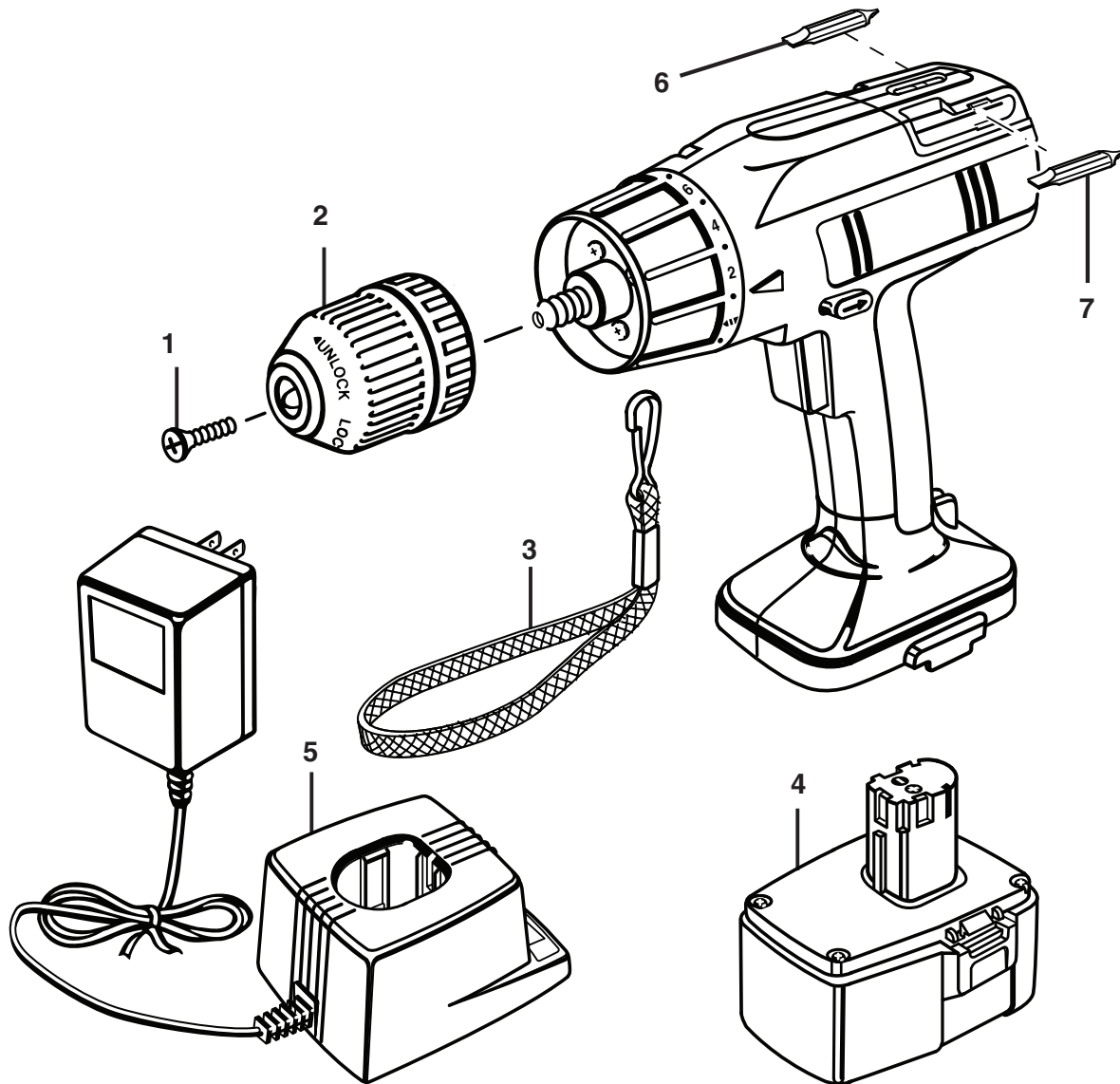

PARTS LIST

KEY NO.	PART NUMBER	DESCRIPTION	QTY.
1	616478003	SCREW (SPECIAL).....	1
2	6903302	CHUCK (ITEM NO. 9-20988)	1
3	9002712	WRIST STRAP	1
4	1311444	BATTERY PACK (ITEM NO. 911004).....	1
5	982031-001	CHARGER W/CHARGING STAND (ITEM NO.911005).....	1
6	6782015	BIT	1
7	6782005	BIT	1
8	982149001	CARRYING CASE (NOT SHOWN).....	1

CRAFTSMAN 3/8 in. 15.6 VOLT CORDLESS DRILL-DRIVER – MODEL NUMBER 973.114250

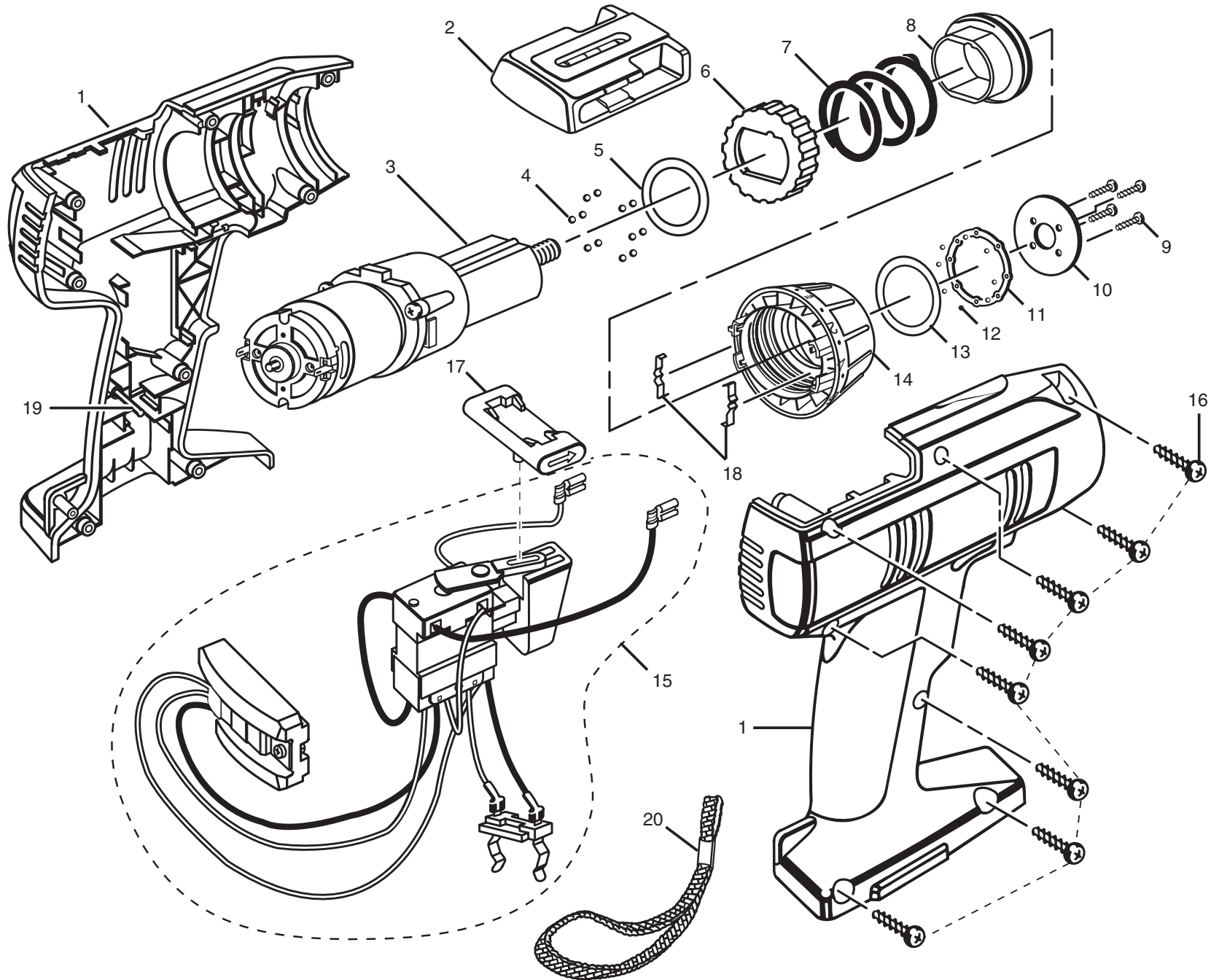

CRAFTSMAN 3/8 in. 15.6 VOLT CORDLESS DRILL-DRIVER – MODEL NUMBER 973.114250

The model number will be found on a label attached to the motor housing. Always mention the model number in all correspondence regarding your **3/8 in. CORDLESS DRILL-DRIVER** or when ordering repair parts.

PARTS LIST

KEY NO.	PART NUMBER	DESCRIPTION	QTY.
1	984263001	HOUSING ASSEMBLY	1
2	3003401	BIT STORAGE W/LEVEL	1
3	984131001	MOTOR W/GEAR TRAIN AND ASSEMBLY	1
4	6722001	CLUTCH BALLS.....	16
5	6711101	CLUTCH WASHER (0.15 mm)	1
	6703502	WASHER (0.3 mm).....	1
	6710501	WASHER (0.8 mm).....	1
6	5267610	LOCATION CUP	1
7	6759101	SPRING.....	1
8	5267511	SLEEVE.....	1
9	6620501	SCREW (M3 x 14 mm)	4
10	6320801	CLUTCH RETAINER	1
11	5267710	BALL RETAINER	2
12	6722101	CLUTCH BALLS.....	8
13	6759001	THRUST WASHER.....	1
14	3568003	CLUTCH CAP.....	1
15	2701053	SWITCH ASSEMBLY.....	1
16	660206042	SCREW (M3.5 x 16 mm)	8
17	5267311	FOWARD/REVERSE SELECTOR	1
18	6320701	SPRING PLATES	2
19	6763101	SPRING PIN.....	1
	983000092	OPERATOR'S MANUAL	
	2-09-10 (REV:01)		