

RYOBI 9 in. BAND SAW – MODEL NUMBER BS901

2

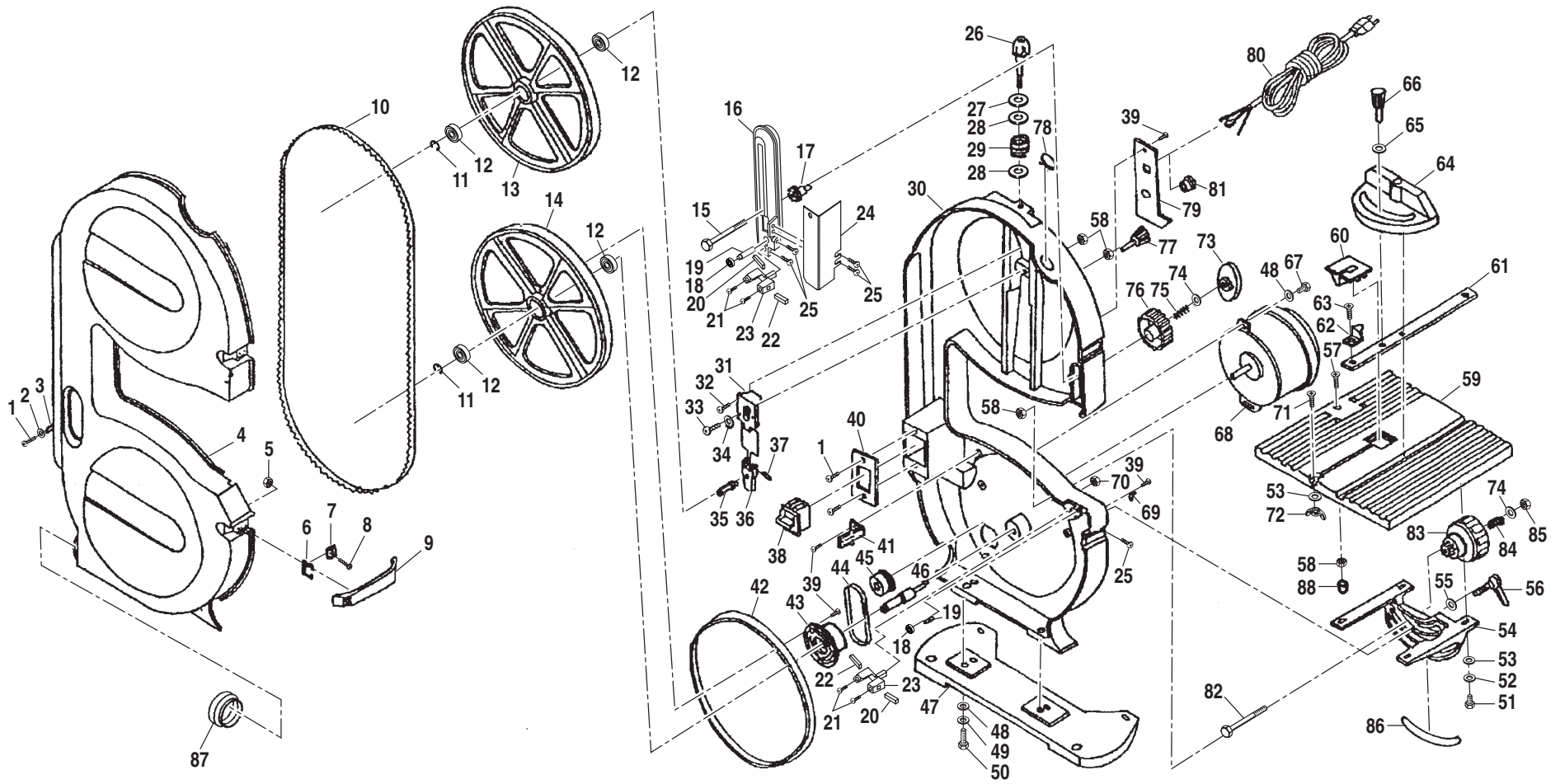

RYOBI 9 in. BAND SAW – MODEL NUMBER BS901

The model number will be found on a plate attached to the motor housing. Always mention the model number in all correspondence regarding your **BAND SAW** or when ordering repair parts.

PARTS LIST

Key No.	Part Number	Description	Qty.	Key No.	Part Number	Description	Qty.
1	BS90100100	* SCREW (M4 X 8 mm)	6	27	BS90102700	WASHER	1
2	BS90100200	WASHER	4	28	BS90102800	STEEL PLATE	2
3	BS90100300	HINGER	2	29	BS90102900	SPRING	1
4	BS90100400	COVER	1	30	BS90103000	ALUMINUM HOUSING	1
5	BS90100500	* NUT (M3)	8	31	BS90103100	ELEVATING PLATE	1
6	BS90100600	BUCKLE SPRING	2	32	BS90103200	* SCREW (M6 X 8 mm)	3
7	BS90100700	CLAMP BRACKET	2	33	BS90103300	SCREW	1
8	BS90100800	* SCREW (M3 X 8 mm)	8	34	BS90103400	WASHER	1
9	BS90100900	LATCH	2	35	BS90103500	SHAFT	1
10	BS90101000	BLADE	1	36	BS90103600	ADJUSTING PLATE	1
11	BS90101100	RETAINING RING	2	37	BS90103700	ELASTIC PIN	1
12	BS90101200	BEARING	4	38	BS90103800	SWITCH	1
13	BS90101300	UPPER WHEEL	1	39	BS90103900	* SCREW (M4 X 10 mm)	7
14	BS90101400	LOWER WHEEL	1	40	BS90104000	SWITCH PLATE	1
15	BS90101500	BOLT	1	41	BS90104100	BRUSH	1
16	BS90101600	BRACKET	1	42	BS90104200	WHEEL TIRE	2
17	BS90101700	GEAR	1	43	BS90104300	BELT WHEEL	1
18	BS90101800	BEARING	2	44	BS90104400	BELT	1
19	BS90101901	PIN	2	45	BS90104500	BELT WHEEL	1
20	BS90102000	GUIDE (B)	2	46	BS90104600	SHAFT	1
21	BS90102100	* SCREW (M5 X 10 mm)	3	47	BS90104700	BASE	1
22	BS90102200	GUIDE (A)	2	48	BS90104800	WASHER	6
23	BS90102300	UPPER GUIDE BRACKET	2	49	BS90104900	WASHER	4
24	BS90102400	BLADE GUIDE	1	50	BS90105000	* BOLT (M10 X 16 mm)	4
25	BS90102500	* SCREW (M5 X 12 mm)	6	51	BS90105100	* BOLT (M6 X 16 mm)	4
26	BS90102600	TENSION KNOB	1	52	BS90105200	WASHER	4

WARNING: Improper repair of a double insulated tool can result in damage to the double insulation system possibly causing electrical shock or electrocution. Any repairs requiring disassembly of your tool requires safety testing and should only be performed by a Ryobi Authorized Service Center. For the service center nearest you call 1-800-525-2579.

* Standard Hardware Item – May Be Purchased Locally

RYOBI 9 in. BAND SAW – MODEL NUMBER BS901

The model number will be found on a plate attached to the motor housing. Always mention the model number in all correspondence regarding your **BAND SAW** or when ordering repair parts.

PARTS LIST

Key No.	Part Number	Description	Qty.	Key No.	Part Number	Description	Qty.
53	BS90105300	WASHER	5	79	BS90107900	FIXING PLATE	1
54	BS90105400	TRUNNION BRACKET	1	80	BS90108000	POWER CORD	1
55	BS90105500	WASHER	1	81	BS90108100	STRAIN RELIEF	1
56	BS90105600	TABLE LOCKING HANDLE	1	82	BS90108200	BOLT	1
57	BS90105700	* SCREW (M6 X 30 mm)	1	83	BS90108300	KNOB	1
58	BS90105800	* NUT (M6)	4	84	BS90108400	SPRING	1
59	BS90105900	TABLE	1	85	BS90108500	* NUT (M6)	1
60	BS90106000	TABLE INSERT	1	86	BS90108600	ANGLE SCALE LABEL	1
61	BS90106100	GUIDE BAR	1	87	BS90108700	ADAPTOR	1
62	BS90106200	POINTER	1	88	BS90110101	RUBBER BUMPER	1
63	BS90106300	* SCREW (M5 X 6 mm)	1	89	BS90113800	SWITCH KEY (NOT SHOWN)	1
64	BS90106400	MITER GUAGE	1	90	BS90108800	DATA PLATE (NOT SHOWN)	1
65	BS90106500	RUBBER WASHER	1	91	BS90108900	BOTTOM WARNING LABEL (NOT SHOWN) ..	1
66	BS90106600	KNOB	1	92	BS90109000	LOGO PLATE (NOT SHOWN)	1
67	BS90106700	* BOLT (M8 X 25 mm)	2	93	BS90109100	TENSION LABEL (NOT SHOWN)	1
68	BS90106800	MOTOR	1	94	BS90109200	DANGER LABEL (NOT SHOWN)	1
69	BS90106900	POINTER	1	95	BS90109300	DEPTH SCALE LABEL (NOT SHOWN)	1
70	BS90107000	* NUT (M4)	1	96	BS90109400	WINDOW VIEWER LABEL (NOT SHOWN) ..	1
71	BS90107100	SCREW (M6 X 20 mm)	1	97	BS90109800	3 mm HEX KEY (NOT SHOWN)	1
72	BS90107200	* WING NUT (M6)	1	98	BS90109900	4 mm HEX KEY (NOT SHOWN)	1
73	BS90107300	LOCK KNOB	1	99	BS90110000	5 mm HEX KEY (NOT SHOWN)	1
74	BS90107400	WASHER	2		972000-883	OPERATOR'S MANUAL	
75	BS90107500	SPRING	1		972000-883R	REPAIR SHEET	
76	BS90107600	ADJUSTING KNOB	1		10-31-03		
77	BS90107700	TRACKING KNOB	1				
78	BS90107800	WINDOW VIEWER	1				

WARNING: Improper repair of a double insulated tool can result in damage to the double insulation system possibly causing electrical shock or electrocution. Any repairs requiring disassembly of your tool requires safety testing and should only be performed by a Ryobi Authorized Service Center. For the service center nearest you call 1-800-525-2579.

* Standard Hardware Item – May Be Purchased Locally