

RYOBI 3/8 in. DRILL - MODEL NUMBER D46C

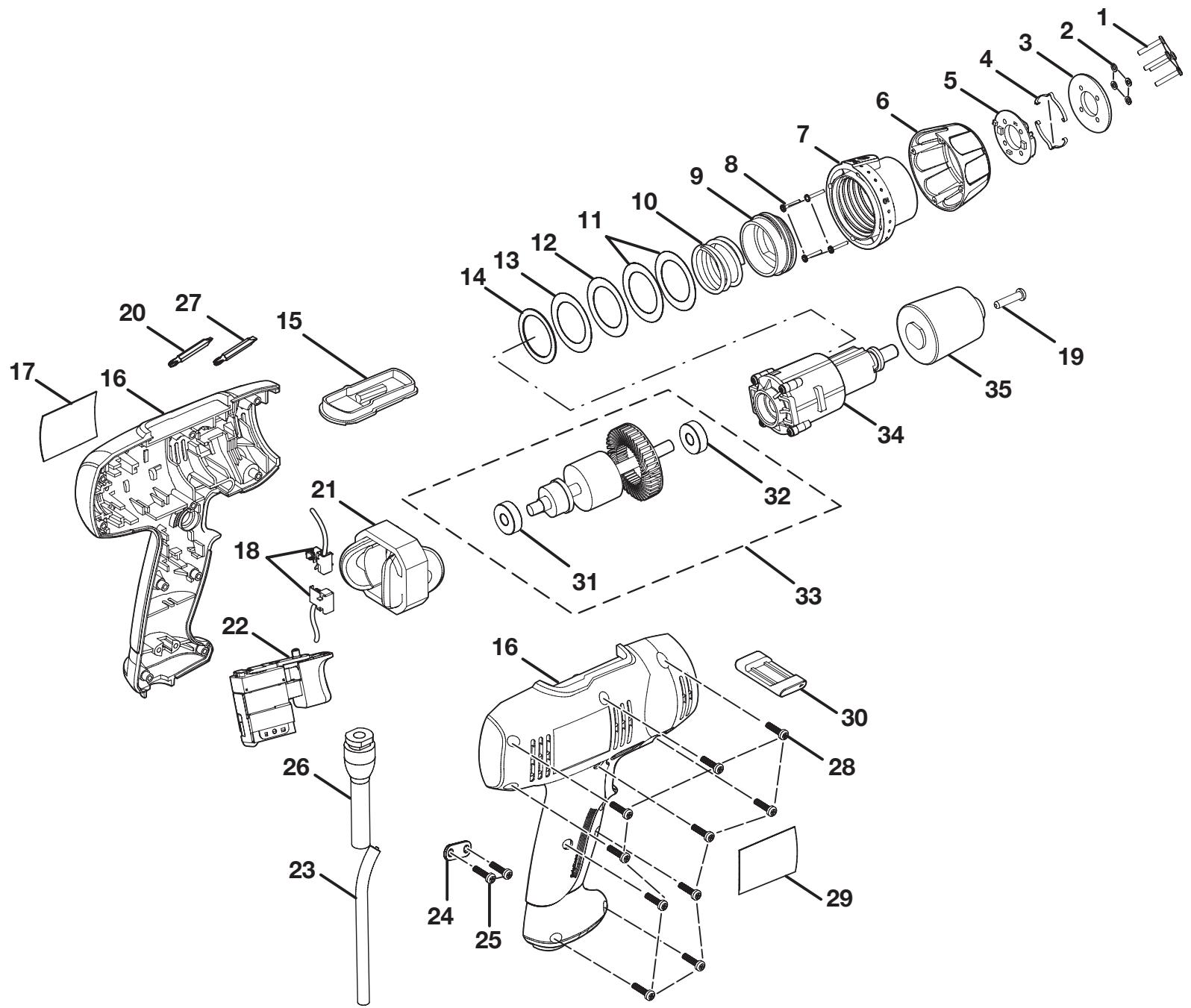

RYOBI 3/8 in. DRILL – MODEL NUMBER D46C

The model number will be found on a label attached to the motor housing. Always mention the model number in all correspondence regarding your **DRILL** or when ordering repair parts.

PARTS LIST

KEY NO.	PART NUMBER	DESCRIPTION	QTY	KEY NO.	PART NUMBER	DESCRIPTION	QTY
1	660211008	SCREW (M3 x 18 mm).....	4	21	740824001	FIELD.....	1
2	6702801	SPRING WASHER (OD5.7 x ID3.1 x 0.8 mm).....	4	22	760677006	SWITCH.....	1
3	6359801	MOUNTING PLATE	1	23	7334501	POWER CORD	1
4	631892001	SPRING PLATE (0.4 mm).....	2	24	6935501	CORD CLAMP	1
5	5434601	SPRING HOLDER.....	1	25	6620801	SCREW (M4 x 12 mm).....	2
6	641112001	CLUTCH CAP (OUTER).....	1	26	5927402	BEND RELIEF	1
7	551009001	CLUTCH CAP (INTER).....	1	27	6782044	DOUBLE BIT (PH3 S7 L50 mm)	1
8	660226010	SCREW (M2 x 14 mm).....	4	28	6620805	SCREW (M4 x 16 mm).....	10
9	5437201	SLEEVE	1	29	940055112	DATA LABEL	1
10	680434002	SPRING (OD35.4 x ID29.6 x 23 t).....	1	30	380005003	FORWARD/REVERSE SELECTOR	1
11	6897003	WASHER (OD43 x ID30 x 0.15 t).....	2	31	681056001	BALL BEARING (608ZZ).....	1
12	6897002	WASHER (OD43 x ID30 x 0.2 t).....	1	32	681057001	BALL BEARING (608RS).....	1
13	6897005	WASHER (OD43 x ID30 x 0.1 t).....	1	33	200443001	ARMATURE ASSEMBLY (INC. KEY NOS. 31-32)..	1
14	670105005	CLUTCH WASHER (OD39.3 x ID30.5 x 1.5 mm) ..	1	34	220017147	GEAR BOX SUB ASSEMBLY	1
15	5660201	BIT HOLDER.....	1	35	690032011	CHUCK (3/8 in.).....	1
16	300141056	HOUSING ASSEMBLY	1	36	300281116	CARRYING CASE (NOT SHOWN).....	1
17	940051043	LOGO LABEL.....	1		983000808	OPERATOR'S MANUAL (960223654)	
18	290069114	BRUSH ASSEMBLY.....	1		7-19-10		
19	6612003	SCREW (M5 x 0.8 x 18.5 mm LEFT HAND).....	1		(REV:02)		
20	6782045	DOUBLE BIT (PH2 S6 L50 mm)	1				

WARNING: Improper repair of a double insulated tool can result in damage to the double insulation system possibly causing electrical shock or electrocution. Any repairs requiring disassembly of your tool requires safety testing and should only be performed by a Ryobi Authorized Service Center. For the service center nearest you call 1-800-525-2579.