

RYOBI 1/2 in. HAMMER DRILL - MODEL NUMBER D552H

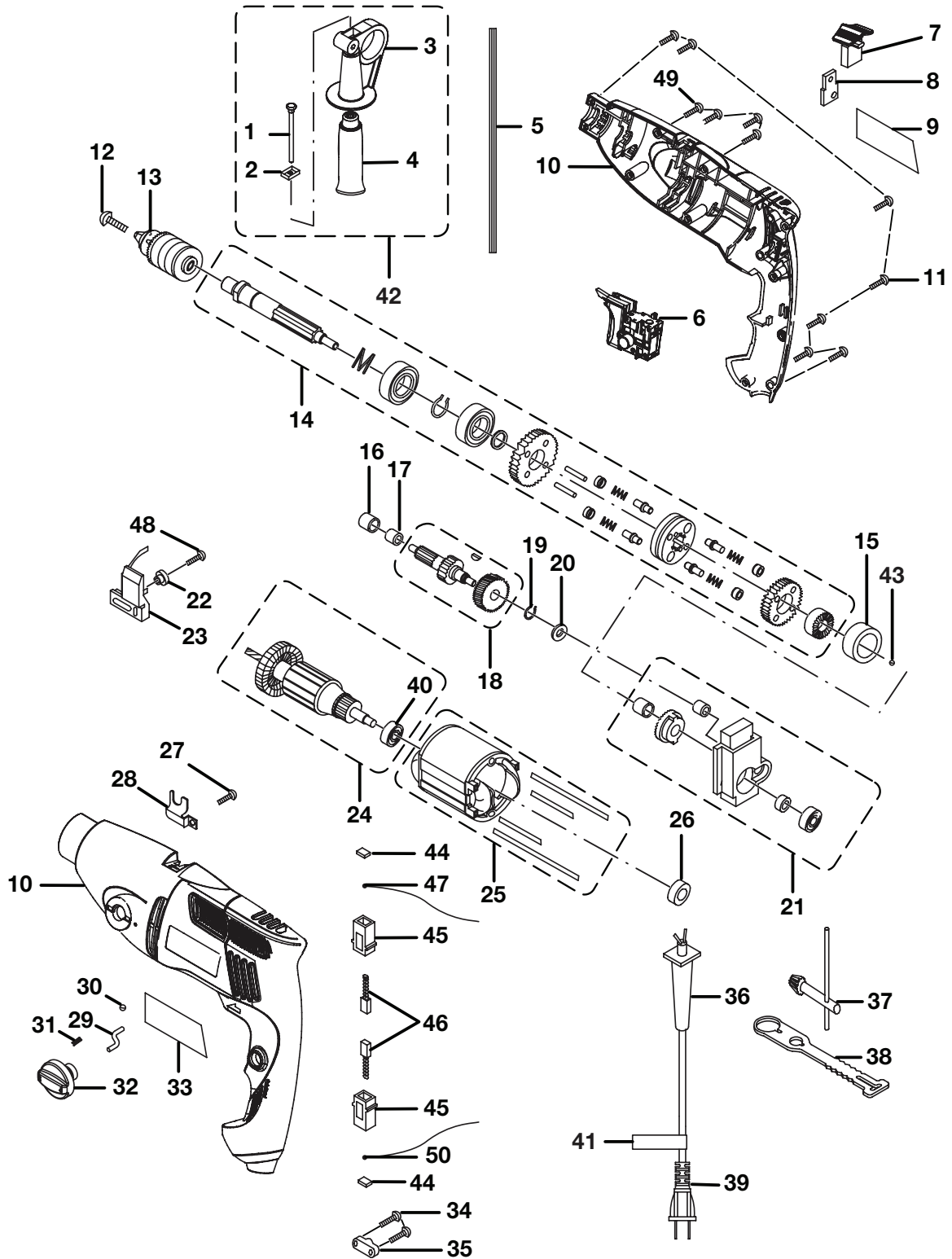

WARNING: Improper repair of a double insulated tool can result in damage to the double insulation system possibly causing electrical shock or electrocution. Any repairs requiring disassembly of your tool requires safety testing and should only be performed by a Ryobi Authorized Service Center. For the service center nearest you call 1-800-525-2579.

RYOBI 1/2 in. HAMMER DRILL – MODEL NUMBER D552H

The model number will be found on a label attached to the motor housing. Always mention the model number in all correspondence regarding your **HAMMER DRILL** or when ordering repair parts.

PARTS LIST

Key No.	Part Number	Description	Qty.
1	039140001073	Screw (M8 x 96 mm).....	1
2	039140001074	Square Washer	1
3	039140001075	Handle Support	1
4	039171001001	Auxiliary Handle.....	1
5	039171001002	Depth Gage	1
6	039171001003	Switch.....	1
7	039140001005	Hammer & Drill Model Shift Button	1
8	039140001006	Impact Plate	1
9	039171001004	Data Label	1
10	039171001005	Housing Assembly.....	1
11	039140001010	Screw (M4.2 x 14 mm).....	7
12	039140001012	Screw (M6 x 22 mm).....	1
13	039171001006	½ In. Chuck	1
14	039171001040	Spindle Shaft & Gear Assembly	1
15	039140001027	Sleeve	1
16	039140001037	Hold Sleeve	1
17	039140001038	Needle Bearing	1
18	039171001008	Gear Shaft Assembly.....	1
19	039140001042	Retaining Ring	1
20	039140001043	Washer.....	1
21	039171001043	Bearing Block Assembly.....	1
22	039140001044	Ring	1
23	039140001045	Shifting Fork Block	1
24	039171001010	Armature Assembly (Inc. Key No. 40).....	1
25	039171001105	Field Assembly	1
26	039140001050	Bearing Cover.....	1
27	039140001052	Screw (M4 x 6 mm).....	1
28	039140001053	Spring Plate	1
29	039140001054	Rocker	1
30	039140001055	Steel Ball.....	1
31	039140001056	Spring	1
32	039140001057	Speed Select Knob.....	1
33	039171001012	Logo Label.....	1
34	039140001066	Screw (M3.9 x 14 mm).....	2
35	039140001067	Cord Clamp	1
36	039140001070	Bend Relief	1
37	039171001014	Chuck Key	1
38	039171001015	Key Holder	1
39	039171001016	Power Cord.....	1
40	039140001048	Ball Bearing (607ZZ).....	1
41	039171001030	Cord Label.....	1
42	039171001031	Auxiliary Handle Assembly (Inc. Key Nos. 1-4)	1
43	039171001032	Steel Ball	1
44	039171001033	Brush Holder Cover	2
45	039171001034	Brush Holder	2
46	039171001035	Brush w/Spring	2
47	039171001036	White Brush Lead.....	1
48	039171001037	Screw (M4 x 10 mm)	1
49	039171001038	Screw (M4.2 x 16 mm).....	4
50	039171001039	Black Brush Lead	1
51	039171001020	Carrying Case (Not Shown).....	1
	987000001	Operator's Manual (039171001021)	
	6-28-12		
	(REV:01)		