

RYOBI SCREW DRIVER – MODEL NO. DSG50

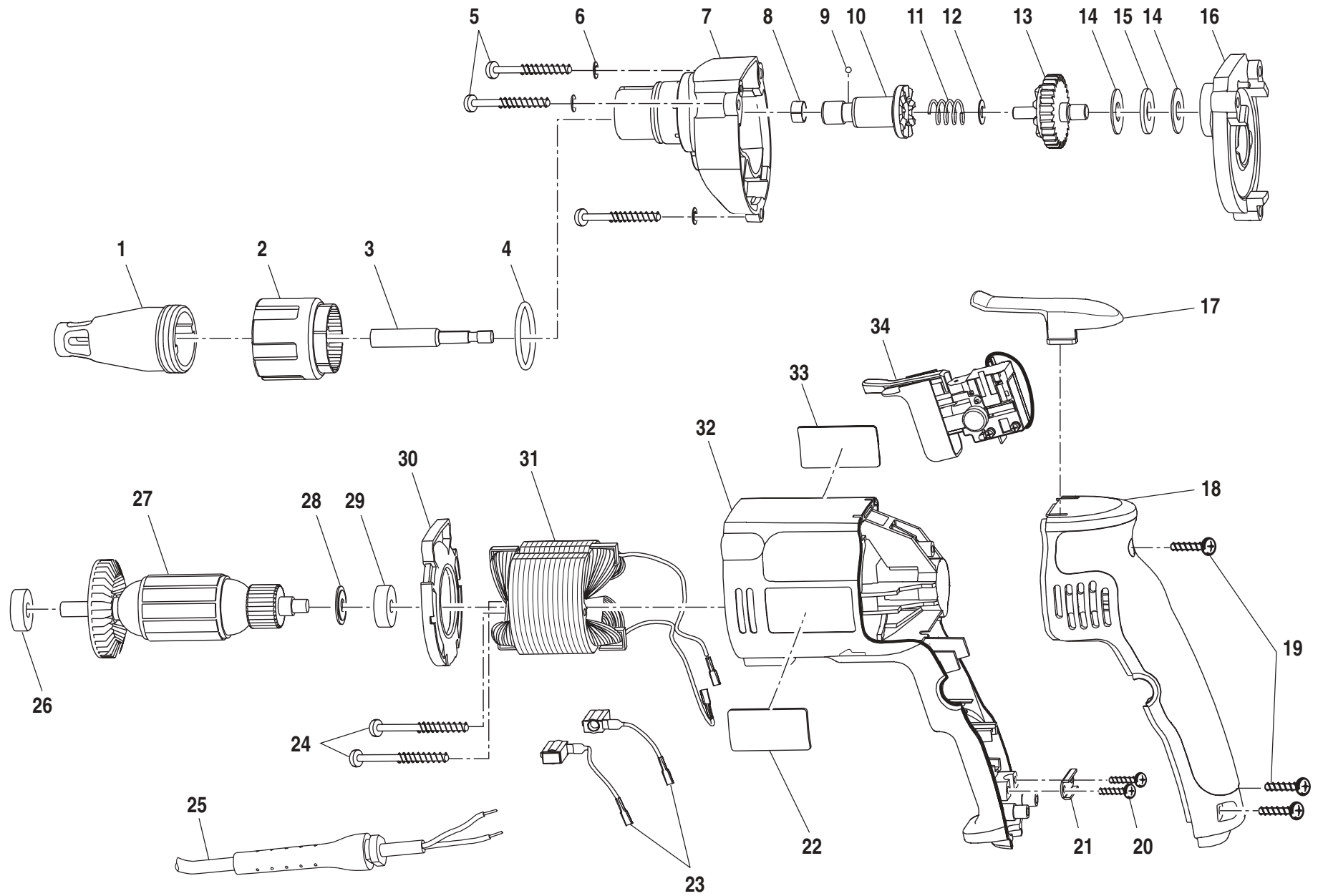

RYOBI SCREW DRIVER – MODEL NO. DSG50

The model number will be found on a plate attached to the motor housing. Always mention the model number in all correspondence regarding your **SCREW DRIVER** or when ordering repair parts.

PARTS LIST

Key Part No. Number	Description	QTY.	Key Part No. Number	Description	QTY.		
1	984440001	ADJUSTABLE NOSE CONE ASSEMBLY	1	19	6620803	* SCREW (M4 X 22 mm)	3
2	5569902	ADJUSTING SLEEVE	1	20	6620801	* SCREW (M4 X 12 mm)	2
3	6911501	1/4 in. MAGNETIC BIT HOLDER	1	21	6906901	CORD CLAMP	1
4	5671401	O-RING	1	22	9421331	LOGO PLATE	1
5	6629901	* SCREW (M5 X 35 mm)	3	23	2906905	BRUSH ASSEMBLY	2
6	6796001	* SPRING WASHER (M5)	3	24	6615601	* SCREW (M4 X 50 mm W/S WASHER)	2
7	984430001	GEAR CASE ASSEMBLY	1	25	7332501	POWER CORD	1
8	6905801	SPRING PLATE	1	26	6906201	BALL BEARING (608LLB)	1
9	6861701	1/8 in. BALL	1	27	984592001	ARMATURE W/BEARINGS (INCLUDES KEY NOS. 26, 28, 29)	1
10	984431001	SLIDE SHAFT ASSEMBLY	1	28	6905501	BEARING COLLAR	1
11	6905902	CLUTCH SPRING	1	29	6906401	BALL BEARING (627LLB)	1
12	6906001	FLAT WASHER	1	30	5570001	FAN CASING	1
13	984432001	OUTPUT GEAR ASSEMBLY	1	31	984593001	FIELD ASSEMBLY	1
14	6906501	AXIAL BEARING WASHER (INA AS)	2	32	5570102	MOTOR HOUSING	1
15	6906601	AXIAL BEARING (10X24X2, AXK1)	1	33	9421442	DATA PLATE	1
16	984433001	INNER CASE ASSEMBLY	1	34	984594001	SWITCH ASSEMBLY	1
17	5574401	BELT HOOK	1	35	670802010	BIT, P2 (NOT SHOWN)	1
18	5570302	HANDLE COVER	1		983000042R	OPERATOR'S MANUAL (REV:00)	
					02-16-05		

WARNING: Improper repair of a double insulated tool can result in damage to the double insulation system possibly causing electrical shock or electrocution. Any repairs requiring disassembly of your tool requires safety testing and should only be performed by a Ryobi Authorized Service Center. For the service center nearest you call 1-800-525-2579.

* Standard Hardware Item — May Be Purchased Locally