



BOSCH

Slide Mitre Saw

GCM12SD | 3 601 F65 011

Table of Content

Spare parts list.....	2
Illustration - Type.....	10

Spare parts list

Item	Part Number	Description	Illustration
45	1 609 B04 487	Detent plate	1
46	1 609 B00 223	Screw	1
47	1 609 B00 225	Nut	1
48	1 609 B04 471	Sliding Plate	1
49	1 609 B01 431	Supporting foot	1
55	1 609 B00 232	Locking Lever	1
56	1 609 B00 233	Locking Lever	1
57	1 609 B00 234	Screw	1
58	1 609 B00 235	Screw	1
59	1 609 B00 236	Shoulder Screw	1
61	1 609 B00 237	Compression Spring	1
62	1 609 B00 238	Shoulder Screw	1
63	1 609 B04 462	Mitre Fence	1
64	1 609 B04 463	Mitre Fence	1
65	1 609 B04 464	Mitre Fence	1
66	1 609 B04 465	Mitre Fence	1
78	1 609 B00 254	Scale	1
79	1 609 B00 255	Clamp Spring	1
81	1 609 B00 256	Wrench Socket	1
239	1 609 B00 533	Rubber Bushing	1
241	1 609 B06 207	Warning Label	1
242	1 609 B06 208	Warning Label	1
243	1 609 B00 543	Warning Plate	1
253	1 609 B02 122	Sticker	1
266	1 609 B00 602	Bolt	1
273	1 609 B00 610	Screw	1
283	1 609 B00 622	Rivet	1
323	1 609 B00 669	Washer	1
329	1 609 B00 678	Screw	1
333	1 609 B04 227	Adjusting Nut	1
334	1 609 B02 145	Hexagon Bolt	1
368	1 609 B02 991	Knob	1
422	1 609 B00 780	Screw	1
423	1 609 B04 225	Plain Washer	1
427	1 609 B05 115	Cable	1

Spare parts list

Item	Part Number	Description	Illustration
433	1 609 B04 954	Label	1
434	1 609 B04 955	Label	1
465	1 609 B01 992	End Clip	1
844	1 609 B02 968	Base	1
851	1 609 B02 964	Extension Stand	1
852	1 609 B02 965	Extension Stand	1
31	1 609 B00 201	Wear Plate	2
83	1 609 B04 470	Support Plate	2
84	1 609 B00 273	Shaft	2
85	1 609 B04 725	Knob	2
96	1 609 B00 284	Knob	2
97	1 609 B00 285	Support bracket	2
98	1 609 B00 286	Cam	2
99	1 609 B04 488	Linkage	2
101	1 609 B00 289	Guide Bracket	2
103	1 609 B00 291	Compression Spring	2
104	1 609 B00 292	Locking Lever	2
105	1 609 B00 293	Lever Shaft	2
106	1 609 B00 294	Cam	2
107	1 609 B00 295	Support bracket	2
108	1 609 B00 296	Support bracket	2
109	1 609 B00 297	Tension Rod	2
111	1 609 B00 298	Tube	2
112	1 609 B00 299	Guide Bracket	2
114	1 609 B04 380	Cover	2
115	1 609 B00 302	Detent Pin	2
116	1 609 B00 303	Compression Spring	2
118	1 609 B00 305	Bolt	2
119	1 609 B00 306	Compression Spring	2
124	1 609 B04 480	Pointer	2
125	1 609 B02 988	Scale	2
126	1 609 B00 312	Plate	2
244	1 609 B00 544	Label	2
245	1 609 B00 546	Label	2
246	1 609 B00 547	Sticker	2

Spare parts list

Item	Part Number	Description	Illustration
247	1 609 B00 548	Sticker	2
267	1 609 B00 603	Lock Nut	2
269	1 609 B00 605	Lock Nut	2
275	1 609 B00 614	Set screw	2
277	1 609 B00 616	Set screw	2
282	1 609 B00 621	Set screw	2
288	1 609 B00 627	Screw	2
298	1 609 B00 638	Spring Pin	2
306	1 609 B00 647	Screw	2
315	1 609 B00 658	Spring Washer	2
320	1 609 B00 664	Washer	2
321	1 609 B00 665	Washer	2
322	1 609 B00 667	Washer	2
326	1 609 B00 673	Lock Nut	2
345	1 609 B00 288	Washer	2
354	1 609 B00 676	Washer	2
412	1 609 B04 477	Leaf Spring	2
414	1 609 B04 479	Rod	2
415	1 609 B04 481	Plate	2
466	1 609 B02 986	Rivet	2
802	1 609 B02 310	Detent Pin	2
813	1 609 B02 966	Detent	2
882	1 609 B02 967	Table	2
42	1 609 B00 212	Washer	3
129	1 609 B00 331	Hinge	3
134	1 609 B00 335	Hinge	3
136	1 609 B00 337	Shaft	3
137	1 609 B00 338	Shaft	3
138	1 609 B00 339	Cable Clip	3
142	1 609 B00 342	Bolt	3
143	1 609 B00 343	Bushing	3
144	1 609 B00 345	Locking Lever	3
145	1 609 B00 346	Clamp Spring	3
146	1 609 B00 347	Adjusting bolt	3
147	1 609 B00 348	Plate	3

Spare parts list

Item	Part Number	Description	Illustration
148	1 609 B00 349	Shoulder Screw	3
149	1 609 B00 350	Knob	3
151	1 609 B00 351	Shoulder Screw	3
152	1 609 B00 352	Detent	3
153	1 609 B00 353	Retaining Plate	3
154	1 609 B00 354	Retaining Plate	3
155	1 609 B00 355	Brake Plate	3
156	1 609 B00 356	Spacer	3
157	1 609 B00 357	Pointer	3
158	1 609 B00 358	Pointer	3
159	1 609 B00 359	Adjusting bolt	3
161	1 609 B00 361	Support bracket	3
162	1 609 B00 362	Bumper	3
164	1 609 B00 364	Shaft	3
167	1 609 B00 367	Screw	3
168	1 609 B00 368	Rubber Plug	3
169	1 609 B00 369	Rubber Plug	3
248	1 609 B00 549	Warning Plate	3
259	1 609 B00 594	Ball	3
265	1 609 B00 601	O-Ring	3
268	1 609 B00 604	Lock Nut	3
272	1 609 B00 609	Bolt	3
274	1 609 B00 612	Screw	3
281	1 609 B00 620	Set screw	3
284	1 609 B00 623	Screw	3
285	1 609 B00 624	Screw	3
289	1 609 B00 630	Screw	3
296	1 609 B00 636	Tapping Screw	3
304	1 609 B00 644	Retaining ring	3
316	1 609 BP7 042	Washer	3
317	1 609 B00 661	Washer	3
325	1 609 B00 672	Lock Nut	3
327	1 609 B00 674	Washer	3
330	1 609 B00 680	Screw	3
331	1 609 B00 681	Thrust Bearing	3

Slide Mitre Saw | GCM12SD | 3 601 F65 011

Spare parts list

Item	Part Number	Description	Illustration
332	1 609 B00 682	Screw	3
337	1 609 B00 689	Screw	3
338	2 610 919 073	Brake Plate	3
339	2 610 919 281	Washer	3
341	1 609 B00 370	Shaft	3
342	1 609 B00 690	Retaining ring	3
343	1 609 B00 691	Nut	3
346	1 609 B00 344	Clamping Band	3
348	1 609 B00 371	Shoulder Screw	3
353	1 609 B00 406	Sticker	3
831	1 609 B02 303	Hinge	3
832	1 609 B02 304	Hinge	3
833	1 609 B02 305	Hinge	3
835	1 609 B02 958	Hinge	3
4	1 609 B06 720	Switch	4
5	1 609 B06 249	Power supply cord	4
32	1 609 B00 203	Pivot	4
33	1 609 B00 204	Torsion Spring	4
34	1 609 B02 581	Bushing	4
35	1 609 B00 206	Wear Plate	4
36	1 609 B00 207	Belt	4
37	1 609 B00 208	Flange	4
39	1 609 B00 210	Flange	4
41	1 609 B00 211	Flange Bolt	4
43	1 609 B00 213	Flange Bolt	4
172	1 609 B00 382	Knob RED	4
174	1 609 B00 384	Gear Cover	4
175	1 609 B00 385	Output Shaft	4
176	1 609 B00 386	Gear	4
177	1 609 B00 387	Pinion	4
178	1 609 B00 388	Pulley	4
179	1 609 B00 504	Belt Cover	4
181	1 609 B00 390	Button	4
182	1 609 B00 391	Locking Pin	4
183	1 609 B00 392	Compression Spring	4

Spare parts list

Item	Part Number	Description	Illustration
186	1 609 B04 485	Trigger	4
192	1 609 B00 401	Clamp	4
194	1 609 B00 417	Compression Spring	4
195	1 609 B00 418	Sleeve	4
196	1 609 B00 419	Rubber Pad	4
197	1 609 B00 430	Connector	4
238	1 609 B01 538	Cable Tape	4
249	1 609 B00 550	Sticker	4
251	1 609 B00 551	Label	4
255	1 609 B00 582	Clip	4
256	1 609 B00 583	Shrinkable Tube	4
257	1 609 B00 592	Key	4
258	1 609 B00 593	Key	4
262	1 609 B00 599	Bearing	4
263	1 609 B02 987	Bearing	4
276	1 609 B00 615	Set screw	4
279	1 609 B00 618	Set screw	4
286	1 609 B00 625	Screw	4
292	1 609 B00 631	Screw	4
293	1 609 B00 632	Screw	4
294	1 609 B00 633	Screw	4
297	1 609 B00 637	Tapping Screw	4
301	1 609 B00 641	Retaining ring	4
303	1 609 B00 643	Retaining ring	4
308	1 609 B00 650	Screw	4
309	1 609 B00 652	Screw	4
310	1 609 B00 653	Screw	4
311	1 609 B00 654	Screw	4
318	1 609 B00 662	Washer	4
418	1 609 B04 486	Linkage	4
419	1 609 B03 777	Set screw	4
420	1 609 B04 865	Button	4
435	1 609 B01 530	Compression Spring	4
871	1 609 B02 997	Arm	4
873	1 609 B02 307	Gear Box	4

Spare parts list

Item	Part Number	Description	Illustration
885	1 609 B06 237	Handle	4
2	1 609 B06 248	Field 115V	5
8	1 609 BN0 314	Nameplate	5
13	1 609 B06 206	Bearing	5
198	1 609 B04 468	Safety Cover	5
203	1 609 B00 445	Safety Cover	5
204	1 609 B04 492	Linkage	5
205	1 609 B00 448	Shoulder Screw	5
206	1 609 B00 449	Bushing	5
211	1 609 B00 453	Screw	5
212	1 609 B00 454	Screw	5
213	1 609 B00 455	Bushing	5
214	1 609 B02 467	Bumper	5
215	1 609 B00 457	Washer	5
216	1 609 B00 458	Quick-Lock	5
218	1 609 B00 460	Bushing	5
219	1 609 B02 583	Intermediate Flange	5
221	1 609 B02 994	Housing Cover	5
222	1 609 B00 476	Baffle	5
223	1 609 B00 478	Brush-Cover	5
224	1 609 B00 479	Insert	5
225	1 609 B00 480	Rubber Bushing	5
229	1 609 B00 502	Rubber Plate	5
232	1 609 B05 010	Dust Bag	5
235	1 609 B00 523	Rubber Pad	5
252	1 609 B00 553	Sticker	5
287	1 609 B00 628	Screw	5
312	1 609 B00 655	Screw	5
313	1 609 B00 656	Screw	5
328	1 609 B02 105	Washer	5
335	1 609 B00 687	Retaining ring	5
336	1 609 B00 688	Washer	5
340	1 609 BP7 124	Roller	5
351	1 609 B00 446	Cord guard	5
801	1 609 B02 302	Motor Housing	5

Spare parts list

Item	Part Number	Description	Illustration
803	1 609 B02 959	Armature 110V	5
810	1 609 B02 314	Carbon-Brush Set	5
817	1 609 B02 598	Plate	5
827	1 609 B02 316	Bearing	5
828	1 609 B02 970	Chute	5
834	1 609 B02 315	Adjustable screw clamp	5
858	1 609 B02 953	Protective Cover	5

Illustration - Type - E

3 601 F65 011

Stand } 18-09-12 **Fig./Abb. 1**

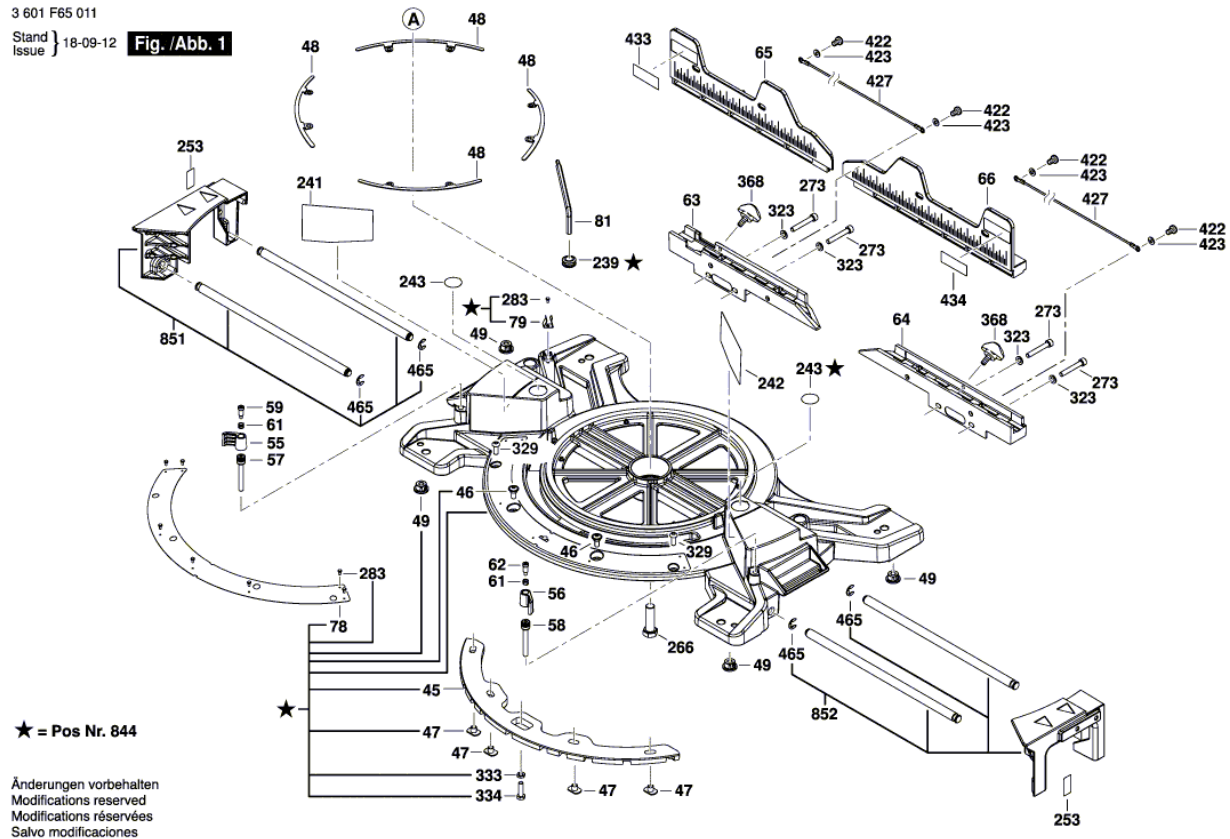
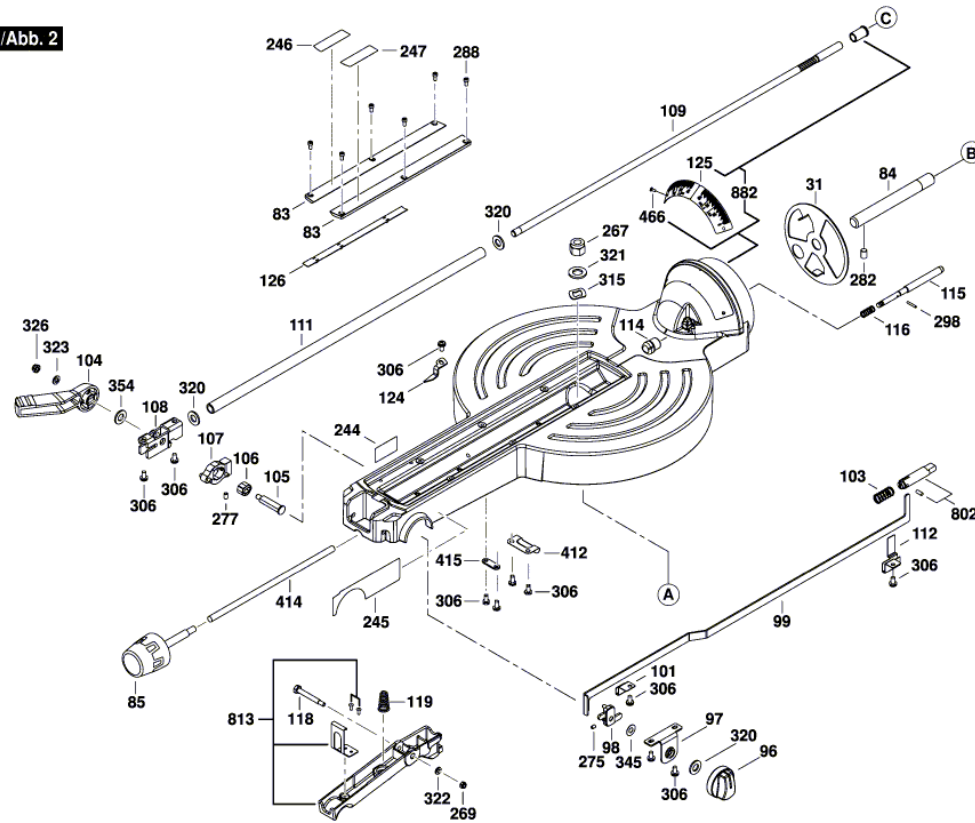

Illustration - Type - E

3 601 F65 011

Stand } 18-09-19
 Issue } **Fig./Abb. 2**



Änderungen vorbehalten
 Modifications reserved
 Modifications réservées
 Salvo modificaciones

Illustration - Type - E

3 601 F65 011

Stand } 18-09-11
Issue } **Fig./Abb. 3**

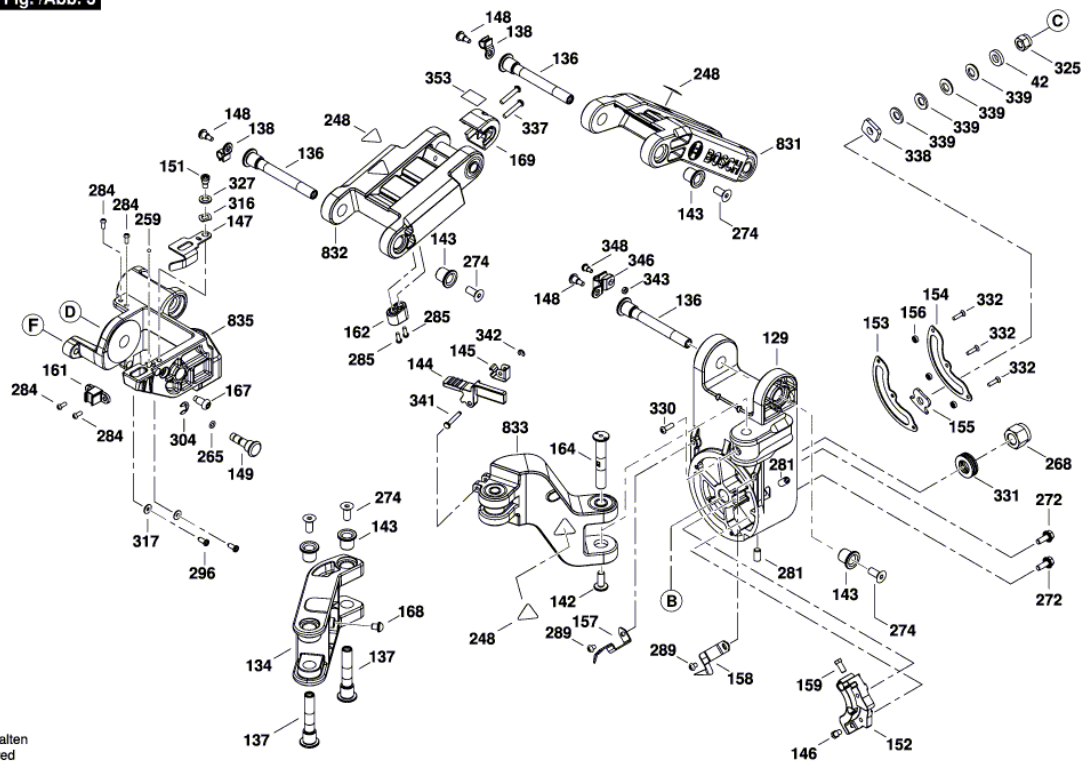

Änderungen vorbehalten
Modifications reserved
Modifications réservées
Salvo modificaciones

Illustration - Type - E

3 601 F65 011

Stand } 19-01
Issue } 20-12-16

Fig./Abb. 4

- Torque values
Anzugsmomente
Couple de serrage
Pares de apriete
- Pos 43 = 4,5 - 5,0 Nm
 - 313 = 2,5 - 2,8 Nm
 - 287 = 2,0 - 2,5 Nm
 - 136 = 3,0 - 3,2 Nm
 - 330 = 2,5 - 3,0 Nm
 - 272 = 25,0 - 28,0 Nm
 - 46 = 3,8 - 4,0 Nm
 - 329 = 3,8 - 4,0 Nm
 - 41 = 15,0 - 15,5 Nm
 - 273 = 7,5 - 8,0 Nm
 - 419 = 0,5 - 0,6 Nm

Änderungen vorbehalten
Modifications reserved
Modificaciones reservadas
Salvo modificaciones

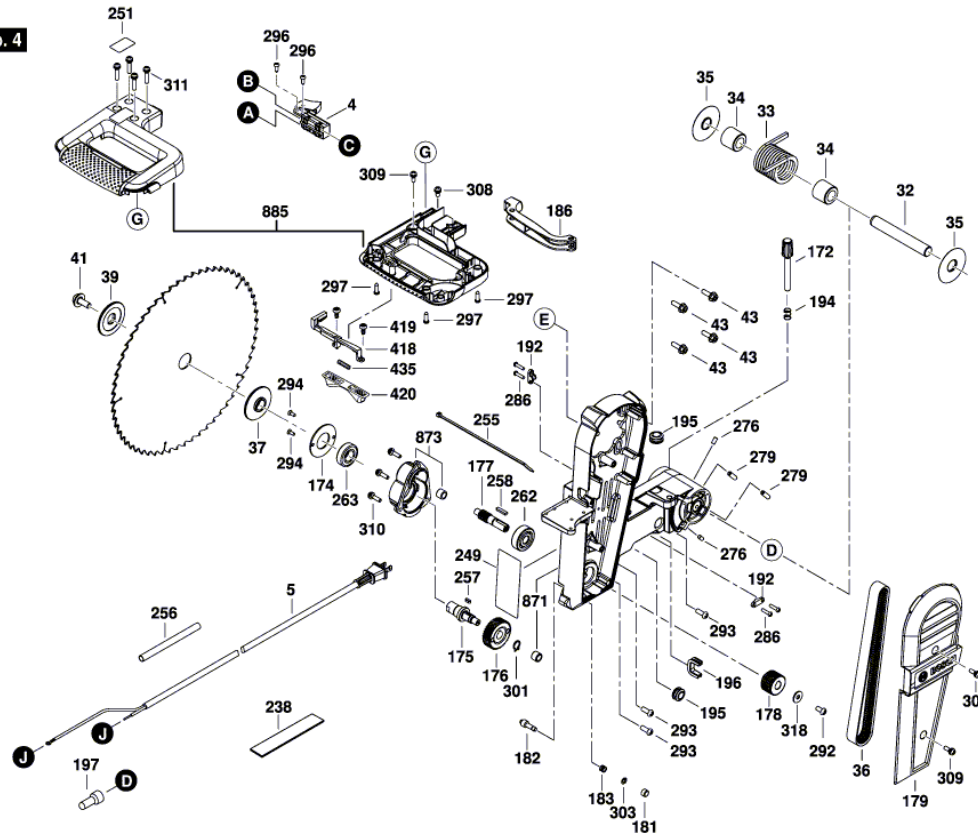
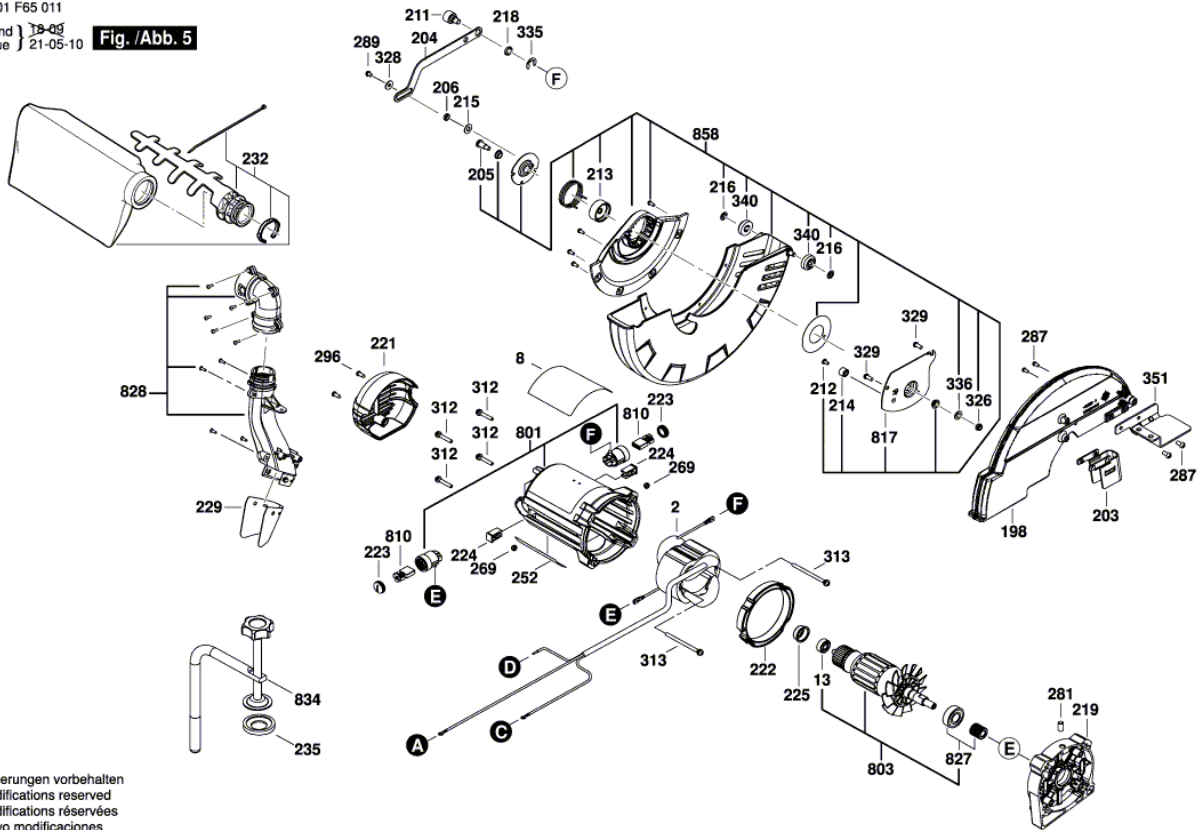

Illustration - Type - E

3 601 F65 011
 Stand } 19-03
 Issue } 21-05-10

Fig. /Abb. 5



Änderungen vorbehalten
 Modifications reserved
 Modifications réservées
 Salvo modificaciones

Illustration - Type - E

3 601 F65 011
 Stand Issue } 18-09-07 **Fig. /Abb. 6**

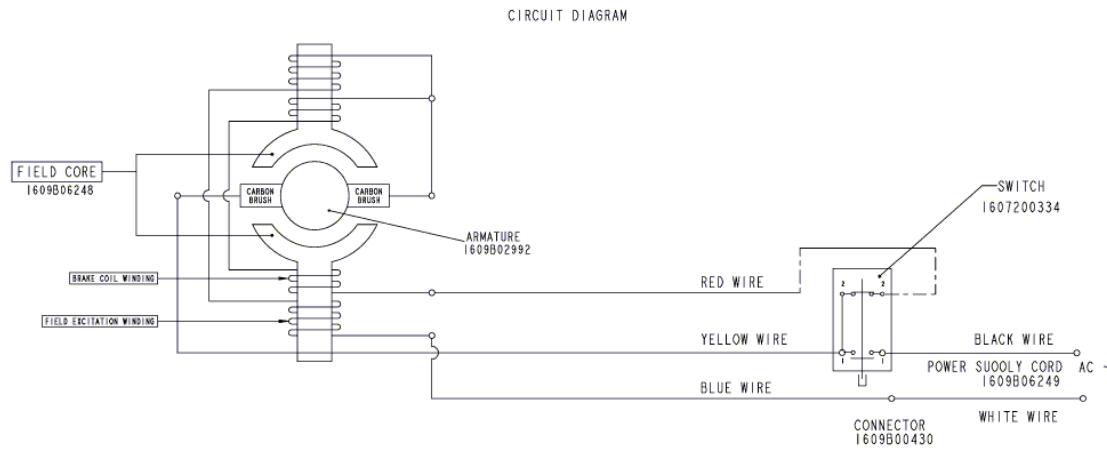

Änderungen vorbehalten
 Modifications reserved
 Modifications réservées
 Salvo modificaciones