



BOSCH

High Frequency Drill

GR.65 | 0 602 117 031

Table of Content

Spare parts list.....	2
Illustration - Type.....	4

Spare parts list

Item	Part Number	Description	Illustration
3	1 600 209 006	Seal Ring	1
4	1 600 209 003	Air-Deflector Ring	1
6	1 600 210 005	O-Ring 66,0x3,0 MM	1
11	1 607 200 038	Switch	1
12	1 600 703 009	Grommet Ø11,5-Ø15,0x150 MM	1
14	1 601 303 003	Fastening Clamp	1
16	1 602 381 001	Insulating Strip 33x10x6 MM	1
18	3 601 106 053	Nameplate	1
21	2 910 141 176	Hex Socket Head Cap Screw M5x55-8.8	DIN 912-1
22	2 910 141 172	Hex Socket Head Cap Screw M5x45-8.8	DIN 912-1
24	2 910 141 158	Hex Socket Head Cap Screw M5X16-8.8	DIN 912-1
25	2 910 021 116	Socket head cap screw	DIN 84-AM4x6-8.8 1
27	2 910 110 122	Pan head screw	DIN 85-MS-M 4x12 1
28	2 910 211 020	Tapping Screw	DIN 7971-BZ3,9x19 1
31	3 600 150 006	Spring Washer Ø4,2 MM	1
32	3 601 321 001	Clamping Saddle	1
33	3 603 133 001	Grooved Nail	DIN 1476-2x5 MM 1
35	3 605 806 116	Spindle Bearing	1
36	1 603 124 039	Drilling Spindle	1
37	1 900 900 201	groove ball bearing	15x32x8 1
38	3 607 030 355	Retaining snap ring	1
39	1 600 108 000	Sealing disk	1
40	1 600 102 003	Shim 0,5 MM THICK	1
41	1 600 300 026	Spacer Bushing	1
42	1 900 900 303	groove ball bearing	15x35x11 1
43	2 916 660 014	Spring retaining ring	DIN 472 35x1,5 MM 1
44	1 600 300 027	Spacer Bushing	1
45	1 606 317 047	Cylindrical Gear	Z=44 1
46	1 606 328 051	Spindle With Gear	Z=9/29 1
47	1 600 100 631	Shim 0,5 MM THICK	1
48	3 604 080 057	Rotor Without Winding	1
48/3	3 606 610 010	Fan	1
49	1 600 501 025	Conical Spring Washer	1

Spare parts list

Item	Part Number	Description	Illustration
50	1 600 108 030	Sealing disk	1
51	3 605 820 056	Bearing Flange	1
52	2 910 021 125	Socket head cap screw DIN 84-AM4x15-8.8	1
53	1 900 905 121	groove ball bearing 12x28x8	1
54	1 610 900 025	groove ball bearing 7x22x7	1
56	3 604 477 008	End Splice	1
57	1 603 402 002	Set screw	1
69	3 600 210 016	O-Ring 22,0x1,5 MM	1
650	1 602 025 022	Auxiliary Handle M14 BLACK	1
650	1 602 025 09Z	Auxiliary Handle	1
800	3 605 133 011	Handle BLUE	1
802	3 605 102 040	Motor Housing	1
810	1 604 229 088	Stator 265V/200HZ	1

Illustration - Type - E

Typ 0 602 1170..

Stand } 90-06
Issue }

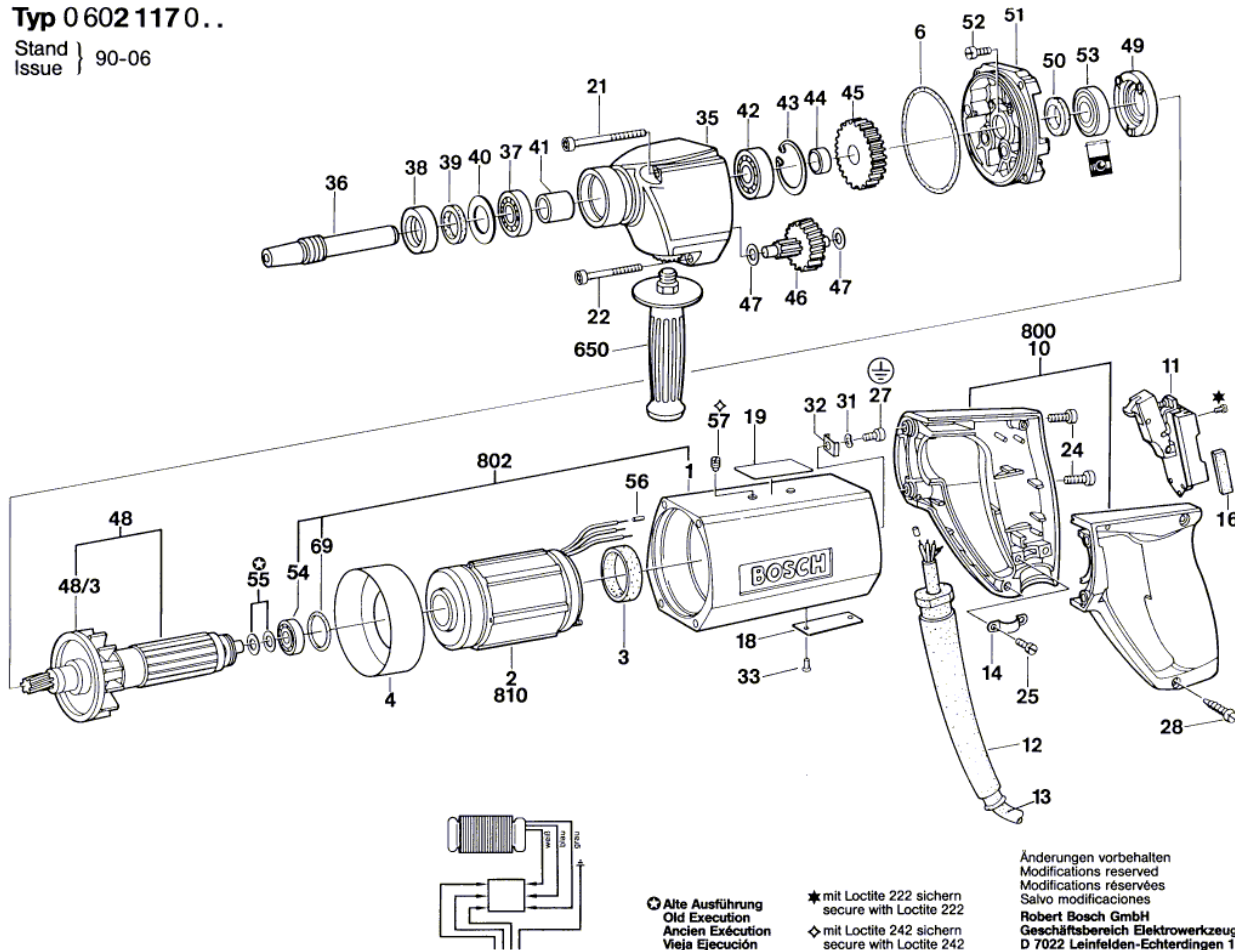

⊕ Alte Ausführung
Old Execution
Ancien Exécution
Vieja Ejecución

* mit Loctite 222 sichern
secure with Loctite 222
◇ mit Loctite 242 sichern
secure with Loctite 242

Änderungen vorbehalten
Modifications reserved
Modifications réservées
Salvo modificaciones
Robert Bosch GmbH
Geschäftsbereich Elektrowerkzeuge
D 7022 Leinfelden-Echterdingen 1
0 602 117 001