



**BOSCH**

# Orbital Sander

GSS 280 AVE | 3 601 B92 981

---

## Table of Content

Spare parts list.....	2
Illustration - Type.....	4

## Spare parts list

Item	Part Number	Description
1	2 605 105 964	Housing Section BLUE
2	2 604 220 750	Field 230-240V
4	2 607 200 688	Switch
6	2 600 703 017	Grommet Ø6,4-Ø7,2x76 MM
14	1 619 P00 290	groove ball bearing
16	2 604 337 003	Brush Holder
19	2 603 490 017	Torx Oval-Head Screw 3x10
22	2 601 328 095	Suction Piece
23	2 916 640 006	Spring retaining ring DIN 471 9x1MM
24	2 600 590 013	Sealing disk
25	2 600 290 030	V-Ring
26	3 608 872 913	groove ball bearing
28	2 602 210 046	Eccentric
29	2 606 610 086	Fan
30	2 603 410 048	Thread-forming tap. Screw M4x8
31	2 600 290 036	Shaft Seal
32	2 600 500 019	Sealing Cover
34	2 600 009 020	Sander Plate
35	2 915 051 107	Hex Nut DIN 439-BM8-04
37	2 603 435 086	Tapping Screw
40	2 603 435 042	Thread-forming tap. Screw
42	2 604 465 115	Suppressor Box
43	2 603 203 041	Damping Element
44	1 607 233 556	Speed governor 230-240V
45	2 915 121 006	Square Nut DIN 562-M6-04
46	2 603 490 023	Torx Oval-Head Screw 4x20
47	2 605 500 208	Housing Cover
48	2 603 490 022	Screw 4x16
49	2 601 035 002	Pusher
50	2 601 328 054	Suction Socket
51	2 601 005 017	Felt Strip
54	2 609 200 379	Tensioning Bracket
56	2 601 901 021	Lever
57	2 603 410 051	Thread-forming tap. Screw
58	2 600 100 713	Spring Washer

## Spare parts list

Item	Part Number	Description
59	2 600 499 078	Guide Bushing
61	2 601 014 021	Pressure Bar
62	2 604 651 029	Coiled Spring
656	2 602 026 175	Auxiliary Handle BLACK
680	2 610 364 015	Hexagon Socket Screw Key 5 MM
803	2 604 011 952	Armature 230-240V
803/13	2 600 905 051	groove ball bearing 7x19x6
803/3/6	2 606 610 076	Fan
805	1 607 000 386	Power supply cord EU 230V 4,15m 2 x 1,0mm H05 RN-F
810	1 607 014 117	Carbon Brush
821	2 605 510 904	Suction Hood
833	2 608 005 902	Spring 4 PIECE
836	2 605 105 966	Motor Housing BLUE
852	2 601 099 902	Swing-Plate
655	2 605 411 234	Dust Chamber
657	2 608 190 030	Punching Tool

Illustration - Type - E

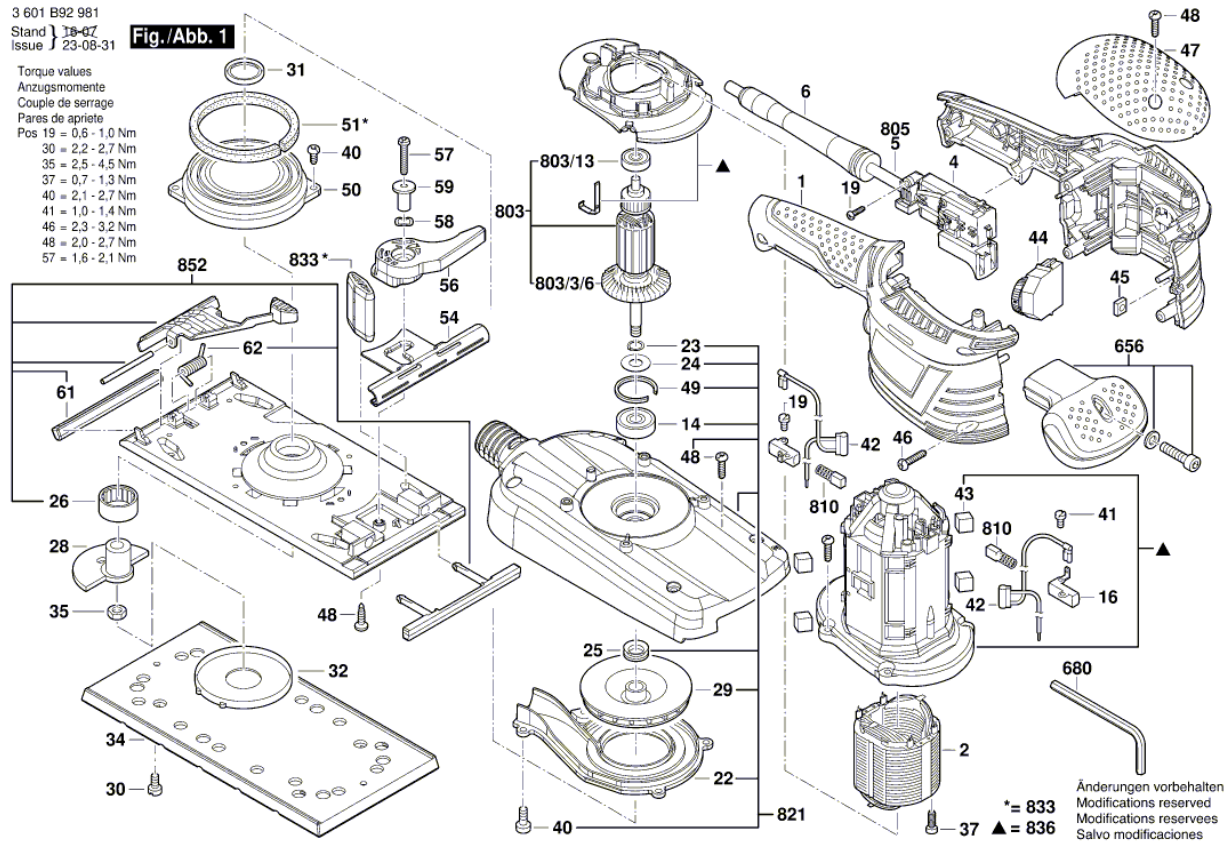
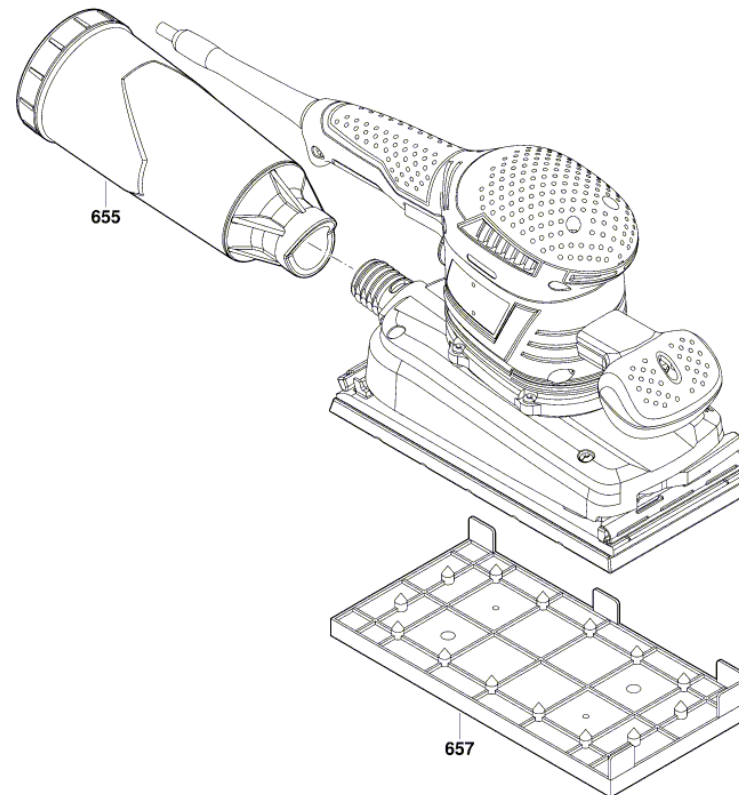

Illustration - Type - E

3 601 B92 981  
Stand } 16-04-06 **Fig./Abb. 2**  
Issue }



Änderungen vorbehalten  
Modifications reserved  
Modifications reserves  
Salvo modificaciones