



BOSCH

Angle Grinder

GWS 10-125C | 0 601 802 743

Table of Content

Spare parts list.....	2
Illustration - Type.....	4

Spare parts list

Item	Part Number	Description
2	1 607 000 F0P	Field
4	1 607 200 086	On-Off Switch
5	1 614 460 073	Power supply cord CN 4,15m 2 x 1,0mm H07 RN-F
6	1 600 703 031	Grommet Ø7,3-Ø8,6x67 MM
7	1 601 302 017	Fastening Clamp
9	1 601 118 672	Manufacturer's nameplate
12	1 607 328 042	Suppression Filter
13	2 600 905 032	Ball Bearing 7x19x6
14	1 600 905 032	groove ball bearing 8x22x7
24	1 605 500 228	Cover BLUE
25	1 605 500 226	Housing Cover BLUE
26	1 600 206 036	Rubber Ring
27	1 600 206 025	Rubber Ring
29	1 600 591 025	Air-Deflector Ring
30	1 600 591 014	Air-Deflector Ring
32	1 607 000 D6A	Grinding Spindle
33	3 600 210 124	O-Ring 46,0x1,1 MM RED
35	1 600 136 013	Shim 0,1 MM THICK
35	1 600 136 014	Shim 0,2 MM THICK
35	1 600 136 015	Shim 0,3 MM THICK
35	1 600 136 020	Shim 0,15 MM THICK
38	1 606 333 616	Crown Gear Z=38
39	1 606 333 617	Bevel Gear Z=11
40	1 600 119 011	Retaining clip
41	1 600 910 018	Needle bearing Ø8xØ12x8 MM
45	1 603 300 016	Hex Nut M7, SW10
47	2 912 401 018	Tapping Screw DIN7981-ST3,9x13-C-Z
49	1 603 435 026	Thread-forming tap. Screw
50	2 912 401 420	Tapping Screw DIN7981-ST3,9x19-F-Z
51	1 607 233 116	Speed governor 220-240V
55	1 603 415 005	Oval-Head Screw
80	1 619 P09 390	Cover Disc
104	1 600 210 044	O-Ring 4,5x1,0 MM BLUE
105	1 601 008 005	Insulating Plate

Spare parts list

Item	Part Number	Description
180	1 601 118 799	Reference Plate
301/1	1 605 108 213	Motor Housing BLUE
301/16	1 601 323 025	Brush Holder
301/17	1 604 652 013	Spiral Spring
301/18	1 602 026 057	Switch Handle BLACK
301/19	1 604 611 026	Compression Spring
301/20	1 602 319 010	Adjusting Slide BLACK
301/48	2 912 401 005	Tapping Screw DIN7981-ST2,9x9,5C-Z
803	1 604 010 640	Armature With Fan 220-240V
808	1 601 11A 3H3	Nameplate
810	1 607 014 176	Carbon-Brush Set
818	2 910 110 048	Pan head screw DIN 85-AM3x6-CUZN
821	1 605 806 465	Gear Housing SILVER
828	1 607 000 347	Bearing Flange Ø 110-125 MM
835	1 606 610 129	Fan
840	1 607 000 253	Push-Button BLACK
890	1 600 210 039	O-Ring 20,35x1,78 MM
891	1 602 025 09T	Auxiliary Handle
891	1 602 025 0A0	Auxiliary Handle
892	1 603 345 043	Round Nut M14
893	1 607 950 052	Pin-Type Face-Wrench
894	1 605 510 313	Protective Cover Ø 125 MM
895	2 605 703 014	Clamping Flange Ø22,3xØ42 MM
896	1 600 A01 6PP	Fast Locking Flange

Illustration - Type - E

0 601 802 743
 Stand 79-82
 Issue 07-09-12

Fig./Abb. 1

Gerad - Verzahnung / Straight Toothed Gears

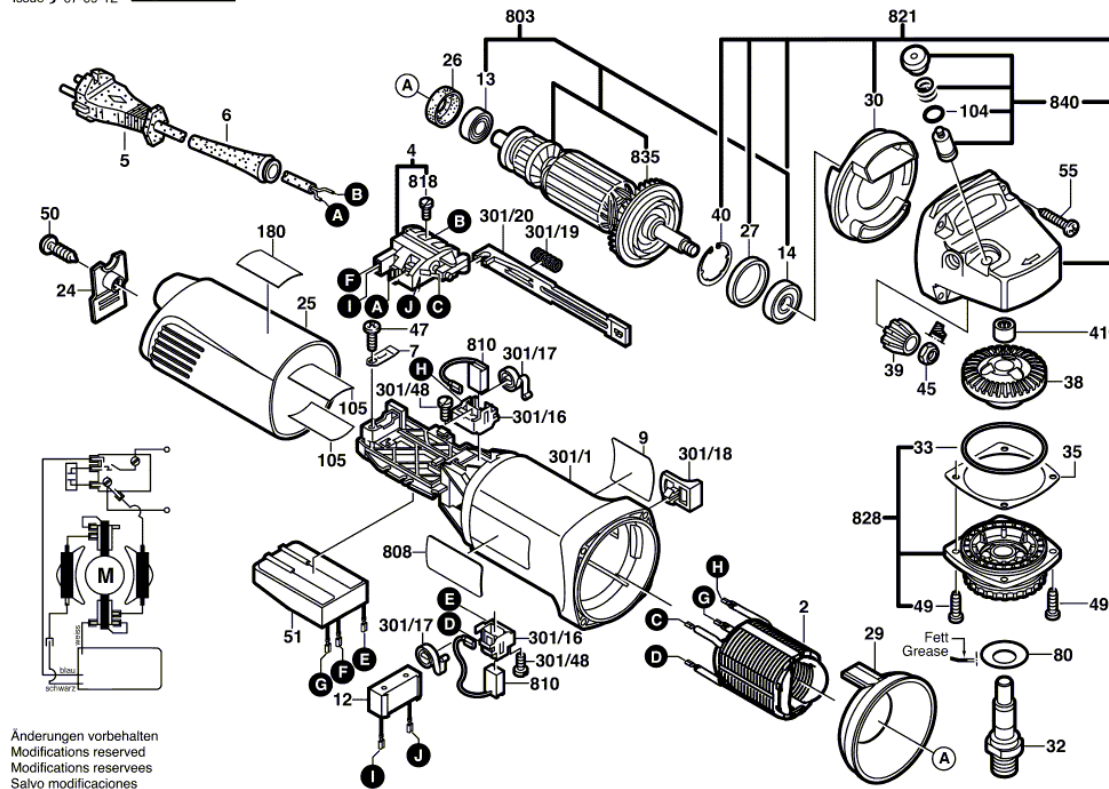

Änderungen vorbehalten
 Modifications reserved
 Modificaciones reservadas
 Salvo modificaciones

Illustration - Type - E

0 601 802 743

Stand ~~01-01-14~~ **Fig./Abb. 2**
Issue / 01-01-30

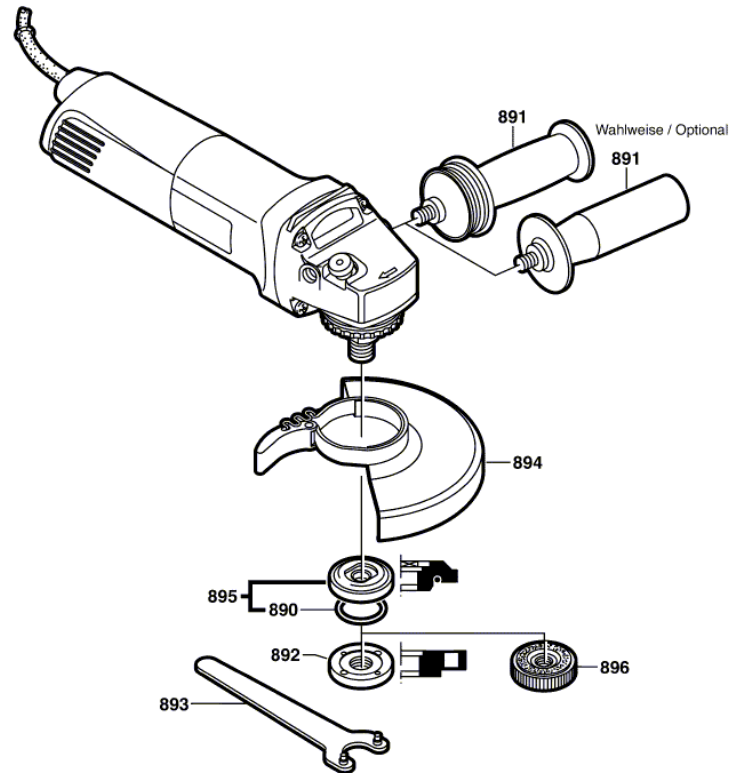

Änderungen vorbehalten
Modifications reserved
Modificaciones reservadas
Salvo modificaciones