

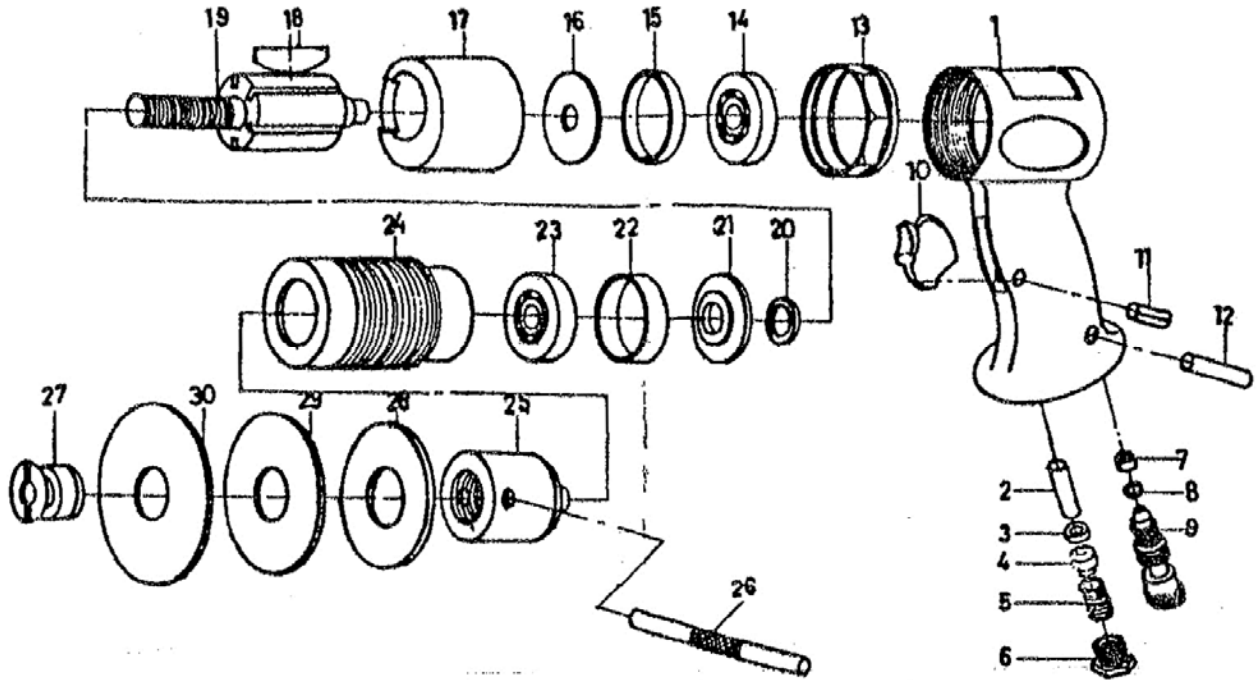

Parts List for JSG-0402, 5" High Speed Sander



Index	Part No.	Description	Qty.
1	822001	Body	1
2	822002	Control Pin	1
3	822003	Rubber Gasket	1
4	822004	Ball	1
5	822005	Spring	1
6	822006	Hose Joint	1
7	822007	Rubber Gasket	1
8	822008	O-Ring	1
9	822009	Regulator	1
10	822010	Trigger	1
11	822011	Pin	1
12	822012	Pin	1
13	822013	Housing Lock Ring	1
14	822014	Bearing	1
15	822015	Spacer	1
16	822016	Rear End Plate	1

Index	Part No.	Description	Qty.
17	822017	Cylinder	1
18	822018	Vane	4
19	822019	Rotor	1
20	822020	Bushing Front End	1
21	822021	Front End Plate	1
22	822022	Spacer	1
23	822023	Bearing	1
24	822024	Cylinder Housing	1
25	822025	Sanding Adaptor	1
26	822026	Holding Tool	1
27	822027	Adaptor Lock Down	1
28	822028	Backing 3" Plate	1
29	822029	Backing 4-1/2" Plate	1
30	822030	Backing 5-1/2" Plate	1

RPK-0402 Repair Kit (contains #3,7,8,18)

JET

427 New Sanford Road
 LaVergne, Tennessee 37086
 Ph.: 800-274-6848
www.jettools.com

Part No. M-JSG-0402
 Revision B 08/2014

Copyright © 2014 JET, a Division of JPW Industries, Inc.

Replacement Parts

To order parts or reach our service department, call 1-800-274-6848 Monday through Friday (see our website for business hours, www.jettools.com). Having the Model Number and Serial Number of your product available when you call will allow us to serve you quickly and accurately.

Specifications for 5" High Speed Sander

Stock Number	JSG-0402
Pad Size (in.).....	3, 4-1/2, 5-1/2 Round
Spindle Thread (in./TPI)	7/16-20
Horsepower	1/2
Free Speed (RPM).....	18,000
Air Consumption (CFM)	4
Air Inlet (NPT/in.).....	1/4
Air Hose (ID/in.).....	3/8
Vibration Value (m/s ²)	1.9
Noise Level (dB).....	106
Overall Length (in.).....	7-1/2
Weight (lbs.)	2-1/2

The above specifications were current at time of publication, but because of our policy of continuous improvement, JET reserves the right to change specifications at any time and without prior notice, without incurring obligations.