

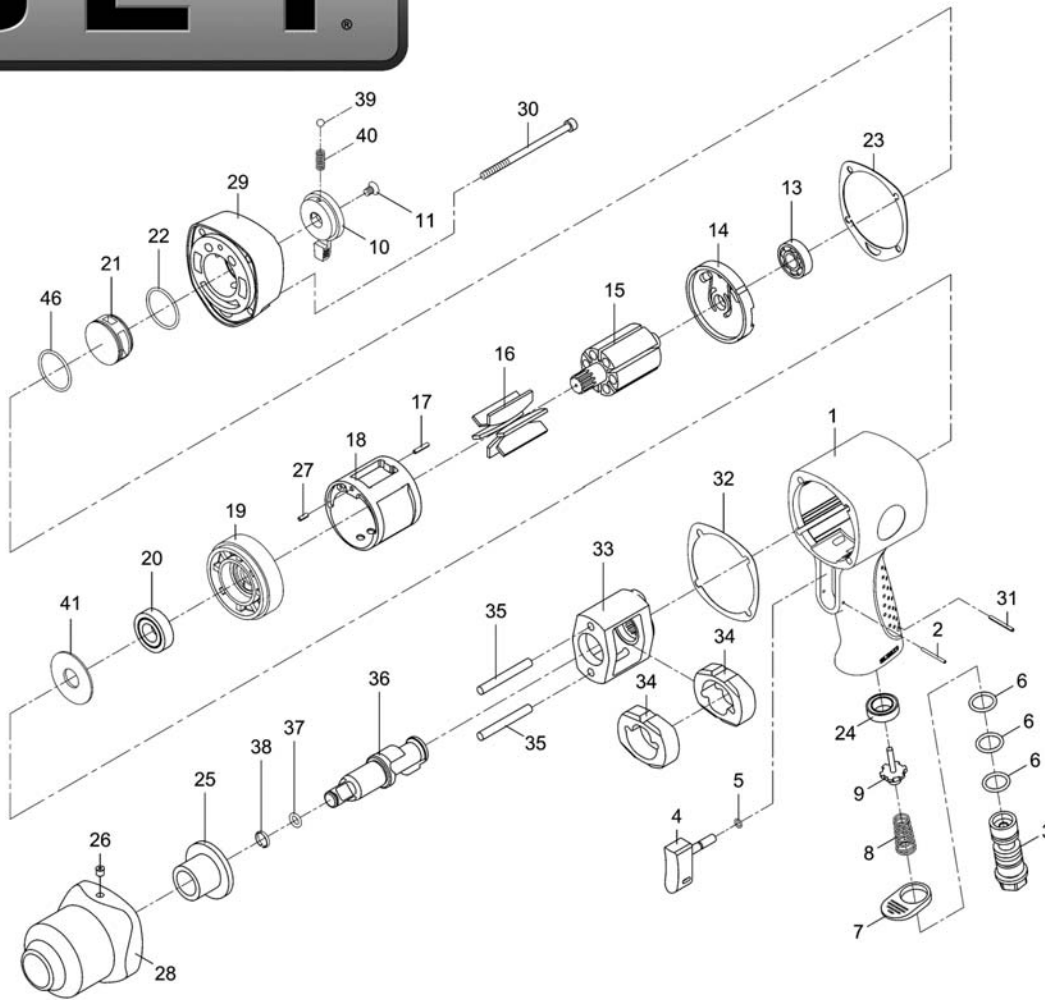

JSM-4340

1/2" Impact Wrench

Stock No. JSM-4340



Parts List on reverse side.

Specifications

Square drive (in.).....	1/4
Bolt capacity (in.).....	3/4
Anvil retainer type.....	Ring
Impact mechanism.....	twin hammer
Maximum torque (ft./lbs.).....	600 ft/lbs
Working torque (ft./lbs.).....	50-550
Torque settings.....	forward 3 steps, reverse 3 steps
Free speed (RPM).....	7,000
Air consumption at load (CFM).....	4.4
Air Inlet (in.).....	1/4 NPT
Air Hose inside diameter (in.).....	3/8
Vibration Value (m/s ²).....	2.8
Noise Level (dB).....	88
Number of vanes in motor.....	6
Overall Length (in.).....	8
Net weight (lbs.).....	4.8

JET

427 New Sanford Road
 LaVergne, Tennessee 37086
 Ph.: 800-274-6848
 www.jettools.com

Part No. M-JSM-4340

Revision A2 06/2014

Copyright © 2014 JET, a Division of JPW Industries, Inc.

Parts List for JSM-4340 Impact Wrench

Index	Part No	Description	Qty	Index	Part No	Description	Qty
1	JSM4340-01	..Motor Housing.....	1	25	JSM4340-25	..Hammer Case Bushing.....	1
2	JSM4340-02	..Spring Pin (2x24)	1	26	JSM4340-26	..Oil Cap	1
3	JSM4340-03	..Air Inlet.....	1	27	JSM4340-27	..Spring Pin (3x8).....	1
4	JSM4340-04	..Trigger	1	28	JSM4340-28	..Hammer Case	1
5	JSM4140-05	..O-Ring (4x1)	1	29	JSM4340-29	..Housing Cap	1
6	JSM4140-41	..O-Ring (15.8x2.4).....	3	30	JSM4340-30	..Screw (M5x90)	4
7	JSM4340-07	..Exhaust Diffuser.....	1	31	JSM4340-31	..Spring Pin (2.5x24).....	1
8	JSM4340-08	..Valve Spring.....	1	32	JSM4340-32	..Gasket.....	1
9	JSM4340-09	..Valve Stem.....	1	33	JSM4340-33	..Hammer Cage.....	1
10	JSM4340-10	..Reversing Valve Knob.....	1	34	JSM4340-34	..Hammer	2
11	JSM4340-11	..Screw (M5x8).....	1	35	JSM4340-35	..Hammer Pin	2
13	BB-6001Ball Bearing (6001).....	1	36	JSM4340-36	..Anvil	1
14	JSM4340-14	..Rear End Plate.....	1	37	40305O-Ring (6.5x2).....	1
15	JSM4340-15	..Rotor.....	1	38	40303Anvil Collar and Seal	1
16	JSM4340-16	..Rotor Blades	6	39	SB-1/8Steel Ball (1/8").....	1
17	JSM4340-17	..Spring Pin (3x14)	1	40	JSM4140-23	..Spring.....	1
18	JSM4340-18	..Cylinder.....	1	41	JSM4340-41	..Washer.....	1
19	JSM4340-19	..Front End Plate	1	46	JSM4340-46	..O-Ring (25x1).....	1
20	BB-6002ZZBall Bearing (6002ZZ)	1		RPK-4340Repair Kit	
21	JSM4340-21	..Reversing Valve	1			(includes #5,6,8,16,22,37,38,39,46)	
22	JSM4340-22	..O-Ring (27x2)	1		RBK-4340Rebuild Kit.....	
23	JSM4340-23	..Gasket	1			(includes #23,32,35,36)	
24	JSM4340-24	..Rubber Spacer.....	1				

To order parts, call our service department at 800-274-6848 Monday through Friday (see our website for business hours, www.jettools.com). Having the Model Number and Serial Number will allow us to serve you quickly and accurately.