

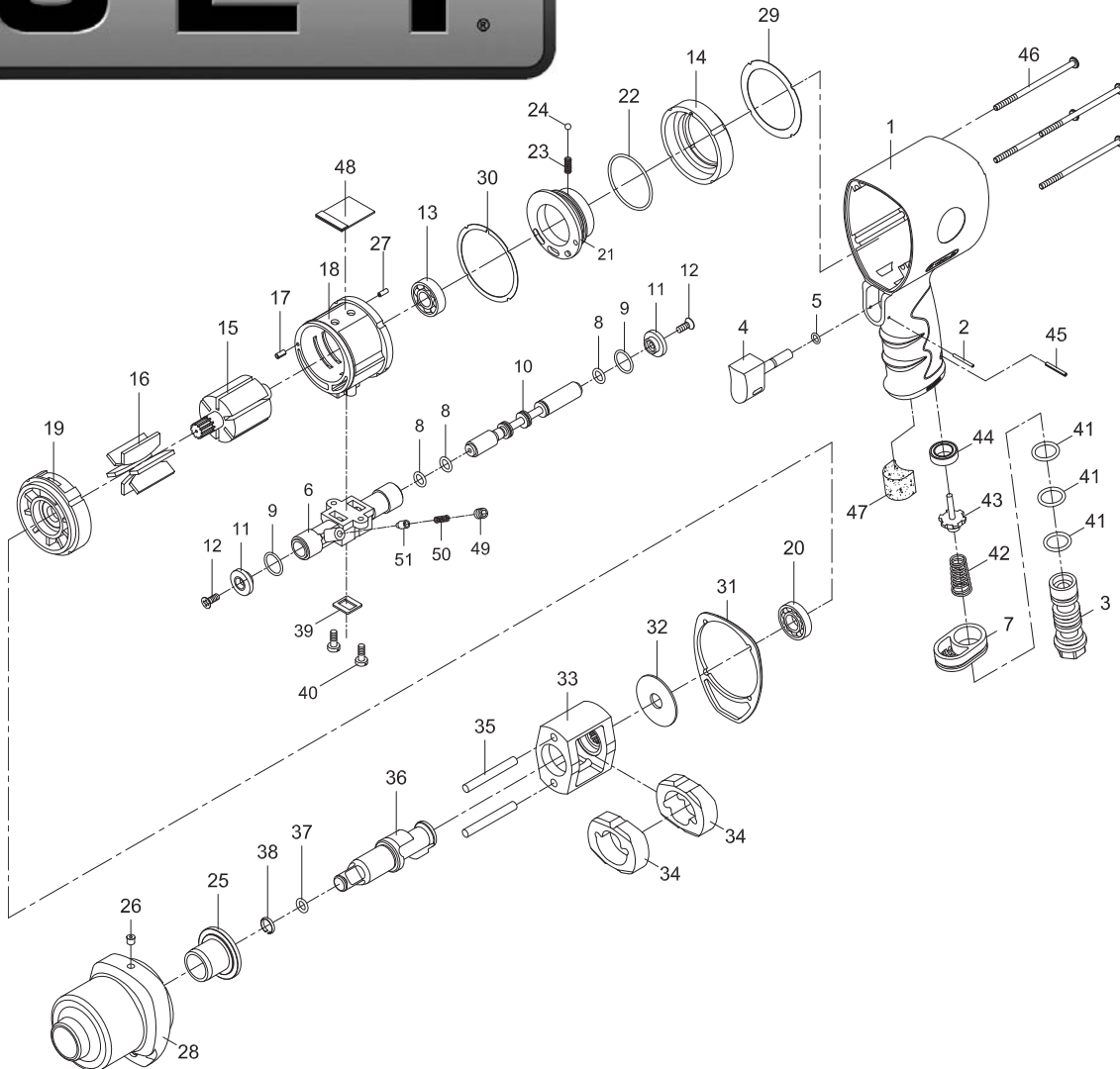

JSM-4343

1/2" Impact Wrench

Stock No. JSM-4343



Index Part No	Description	Qty
1..... JSM4343-01	Motor Housing	1
2..... JSM4140-02	Spring Pin (2x20)	1
3..... JSM4140-03	Air Inlet	1
4..... JSM4140-04	Trigger	1
5..... JSM4140-05	O-Ring (4x1)	1
6..... JSM4343-06	Reverse Valve	1
7..... JSM4140-07	Exhaust Diffuser	1
8..... JSM4140-08	O-Ring (6.45x0.86)	3
9..... JSM3330-09	O-Ring (11.4x1.25)	2
10..... JSM4343-10	Reverse Stem	1
11..... JSM4140-11	Button	2

Index Part No	Description	Qty
12..... JSM4140-12	Screw (M3x8)	2
13..... BB-6001	Ball Bearing (6001)	1
14..... JSM4343-14	Fixed Ring	1
15..... JSM4343-15	Rotor	1

Parts List continued on back page

To order parts, call our service department at 800-274-6848 Monday through Friday (see our website for business hours). Having the Model Number and Serial Number will allow us to serve you quickly and accurately.

JET
 427 New Sanford Road
 LaVergne, Tennessee 37086
 Ph.: 800-274-6848
 www.jettools.com

Part No. M-JSM-4343
 Revision B1 06/2014

Copyright © 2014 JET, a Division of JPW Industries, Inc.

Index Part No	Description	Qty	Index Part No	Description	Qty
16	JSM4343-16 Rotor Blade	6	36	JSM4340-36 Anvil (1/2")	1
17	JSM4140-17 Spring Pin (2.5x5)	1	37	40305 O-Ring (6.5x2)	1
18	JSM4343-18 Cylinder	1	38	40303 Retaining Ring	1
19	JSM4343-19 Front End Plate	1	39	JSM4140-39 Gasket	1
20	72021 Ball Bearing (EE4)	1	40	JSM4140-40 Screw	2
21	JSM4343-21A Air Regulator	1	41	JSM4343-41 O-Ring (15.54x2.62)	3
22	JSM4343-22A O-Ring (38.5x2)	1	42	JSM4340-08 Valve Spring	1
23	JSM4140-23A Spring	1	43	JSM4340-09 Valve Stem	1
24	SB-9/64 Steel Ball (9/64)	1	44	JSM4340-24 Rubber Spacer	1
25	JSM4343-25 Anvil Bushing	1	45	JSM4140-45 Spring Pin (2.5x20)	1
26	JSM4340-26 Oil Cap (7/32")	1	46	JSM4343-46 Screw (M4x90)	4
27	70117 Spring Pin (2x5)	1	47	JSM7572-67 Muffler Material	1
28	JSM4343-28 Hammer Case	1	48	JSM4343-48 Muffler Material	1
29	JSM4343-29 Gasket	1	49	TS-1521011 Set Screw (M4x4)	1
30	JSM4343-30 Gasket	1	50	JSM4140-50 Spring	1
31	JSM4343-31 Gasket	1	51	JSM4140-51 Pin	1
32	JSM4343-32 Washer	1			
33	JSM4343-33 Hammer Cage	1			
34	JSM4340-34 Hammer	2		RPK- 4343A...Repair Kit ¹	
35	JSM4340-35 Hammer Pin	2		RBK- 4343.....Rebuild Kit ²	

¹ Contains Index No.'s 5, 8, 9, 16, 22, 24, 37, 38, 42

² Contains Index No.'s 29, 30, 31, 35, 36, 39

Specifications for JSM-4343:

Square drive	1/2"
Bolt capacity	5/8"
Anvil retainer type	Ring
Impact mechanism	twin hammer
Maximum working torque	550 ft/lbs
Torque settings	forward 3 steps/reverse 3 steps
Free speed	7000 RPM
Air pressure	90 psi
Air consumption at load	4 CFM
Air Inlet	1/4" NPT
Air Hose inside diameter	3/8"
Vibration Value	6.8 m/s ²
Noise Level	83 dB
Number of vanes in motor	6
Overall Length	7-3/16"
Net weight	4 lbs
Shipping weight	4.50 lbs