

## K760

Reservdelar

Spare parts

Ersatzteile

Pieces de rechange

Piezas de repuesto

Ricambi

Peças sobresselente

# A K760

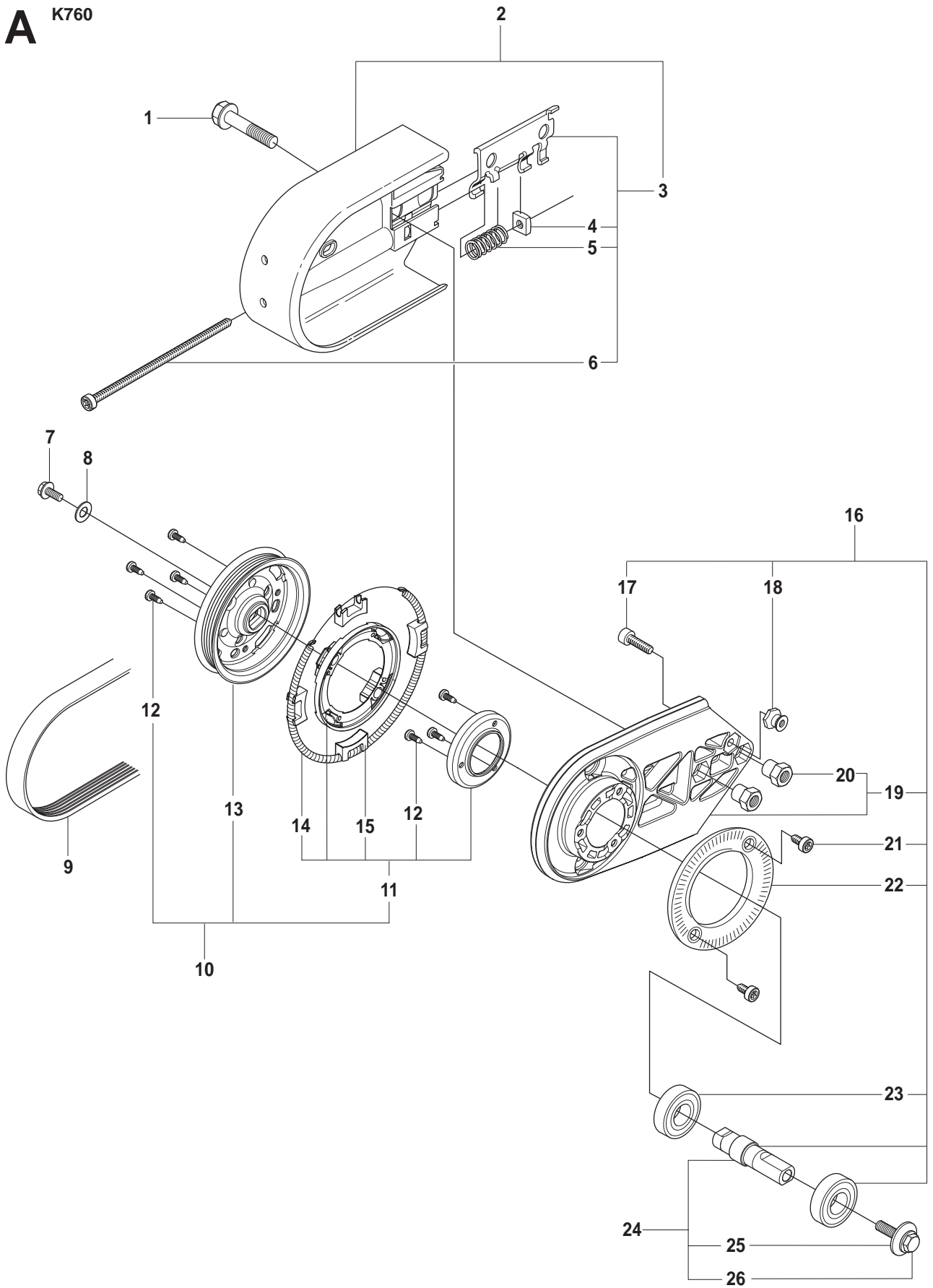

★Vベルトの張り直し  
 Vベルトカバー上の2箇のナットを緩め、Vベルトカバー上の「矢印」位置に四角ナットをセットします。再び2箇のナットを締め付けます。



27

**Page A**  
**K760**

Pos.	Part No.	Description	Quantity	Notes	New Part
1	506 28 44-01	COLLAR SCREW	2		
2	506 39 36-02	BELT GUARD	1	Incl. 3	
3	506 26 66-04	BELT TENSIONER ASSY	1	Incl. 4 - 6	
4	506 40 93-01	NUT	1		
5	506 26 68-01	COMPRESSION SPRING	1		
6	503 20 72-05	SCREW	1		
7	503 20 00-45	SCREW	1		
8	503 23 01-16	WASHER STEEL	1		
9	544 90 84-02	BELT	1		
10	504 03 70-07	PULLEY WITH RETARDER	1	Incl. 11 - 13	
11	505 44 54-03	RETARDER CPL	1	Incl. 12, 14 - 15	
12	503 21 28-10	SCREW	7		
13	504 06 22-01	PULLEY	1		
14	544 44 10-01	SPRING	1		
15	544 44 04-02	BRAKE SHOE	4		
16	506 39 42-08	BEARING HOUSING	1	Incl. 17 - 19, 21 - 23	
17	505 57 41-16	SCREW	1		
18	506 14 32-01	TORSION STOP	1		
19	506 39 42-06	BEARING HOUSING	1	Incl. 20	
20	506 28 73-01	NUT	2		
21	503 21 53-10	SCREW	2		
22	506 28 84-01	RATCHET FLANGE	1		
23	503 25 21-01	BALL BEARING	2		
24	506 29 83-65	SHAFT	1	Incl. 25 - 26	
25	506 13 95-11	WASHER	1		
26	506 13 96-01	COLLAR SCREW	1		

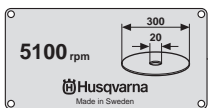
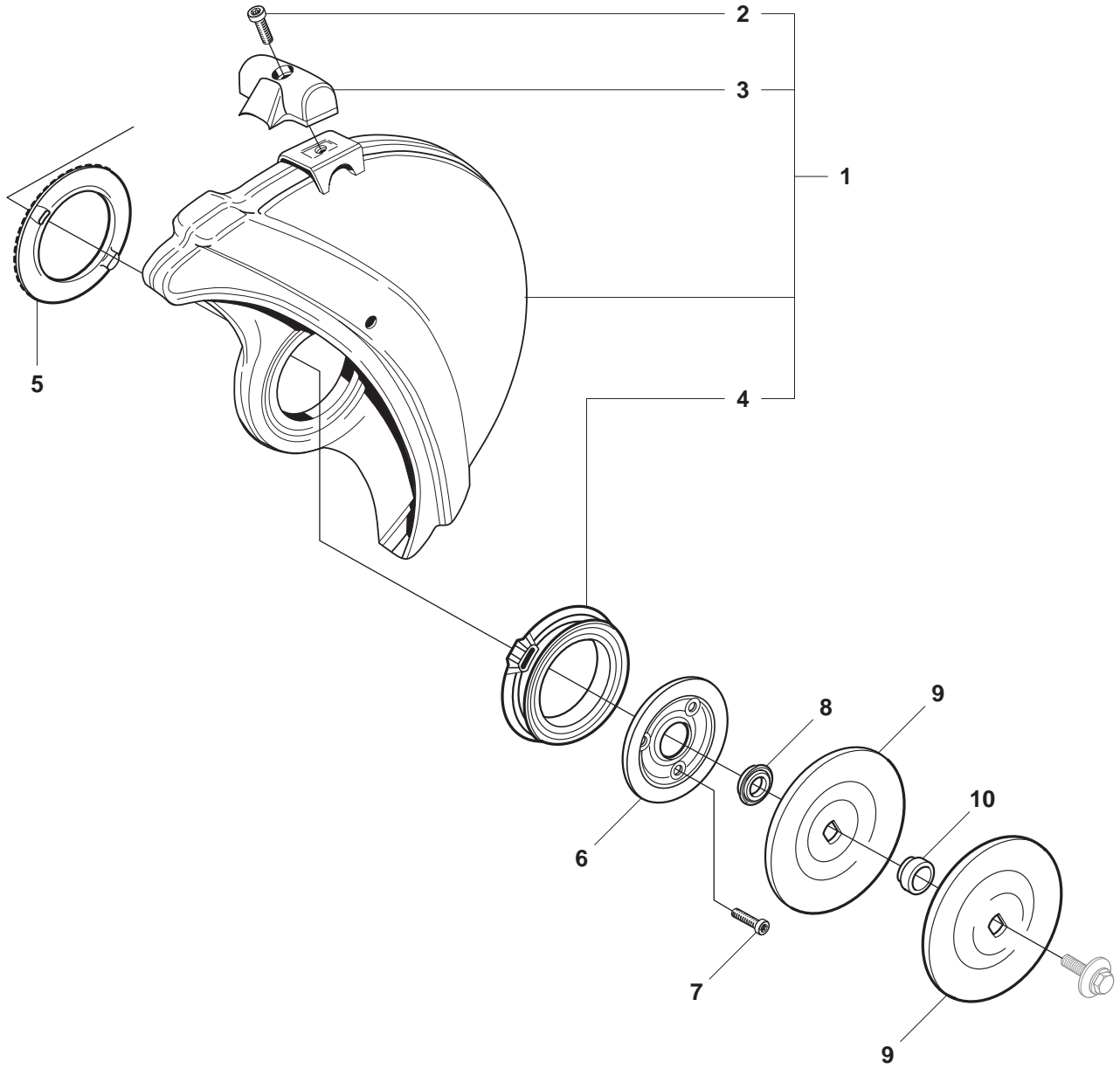

11

**△ 取扱上のご注意 △**

パートナーカッターは、取扱いを誤ると危険を及ぼすことがあります。安全作業のために取扱説明書に従ってください。

- このパートナーカッターは、全ての使用法、メンテナンス方法、安全面の注意を、よく読み、理解しよて整備して下さい。
- 器具として取扱われ、パートナーカッター一同として取扱いされる場合は必ず使用して下さい。
- 器具に付属のディスクカッターに適合しないディスクは使用しないで下さい。
- 常に、正確な切断、刈り込み、刈り取り、刈り取り、安全作業を行い、使用して下さい。
- 器具は、作業終了後、必ず電源を切り、安全に保管して下さい。
- ディスクカッターの取扱いや修理は、必ず取扱説明書に従って行って下さい。
- 使用中は、フレッドをコントロールし、無理に押し込まないで下さい。
- 取扱説明書の注意事項に従って安全に使用して下さい。

Husqvarna

12

**御注意**

本機に使用するカッターディスク（替刃）は輸入品。国産品とメーカー指定品も御使用下さい。ディスクには必ずHusqvarna（ハスクバーナ）の表示があります。国産品のディスクは安全性に欠けます。指定外のディスクを使用した際の事故については、当社は責任を負いません。尚、取扱説明書を見、御読みの上御使用下さい。

Husqvarna

13

**Page B**  
**K760**

Pos.	Part No.	Description	Quantity	Notes	New Part
1	506 34 05-42	WHEEL GUARD ASSY	1	12", Incl. 2 - 4	
1	506 34 05-44	WHEEL GUARD ASSY	1	14", Incl. 2 - 4	
2	503 21 53-20	SCREW	1		
3	506 34 46-02	HANDLE	1		
4	506 26 63-02	LINING	1		
5	506 26 64-01	SCREEN PATTERN FLANG	1		
6	506 26 65-01	FLANGE	1		
7	505 57 41-16	SCREW	3		
8	506 32 48-01	SUPPORT FLANGE	1		
9	506 02 87-01	FLANGE WASHER	2	Diam 105 mm	
9	506 07 09-01	FLANGE WASHER	2	Diam 119 mm	
10	506 37 96-20	BUSHING	1	Diam 20 mm	
10	506 37 96-22	BUSHING	1	Diam 22,2 mm	
10	506 37 96-25	BUSHING	1	Diam 25,4 mm	
10	506 02 88-30	BUSHING	1	Diam 30,5 mm	
11	506 28 41-04	LABEL	1	12", Diam 1"	
11	506 28 41-02	LABEL	1	12", Diam 20 mm	
11	506 28 41-14	LABEL	1	14", Diam 1"	
11	506 28 41-12	LABEL	1	14", Diam 20 mm	

**C** K760

Husqvarna

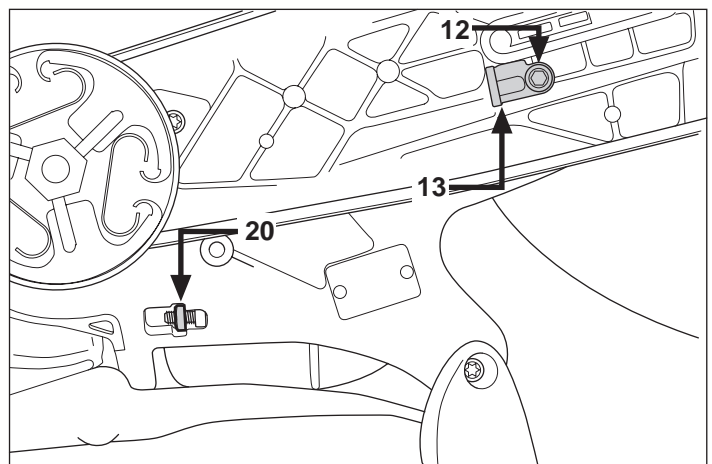
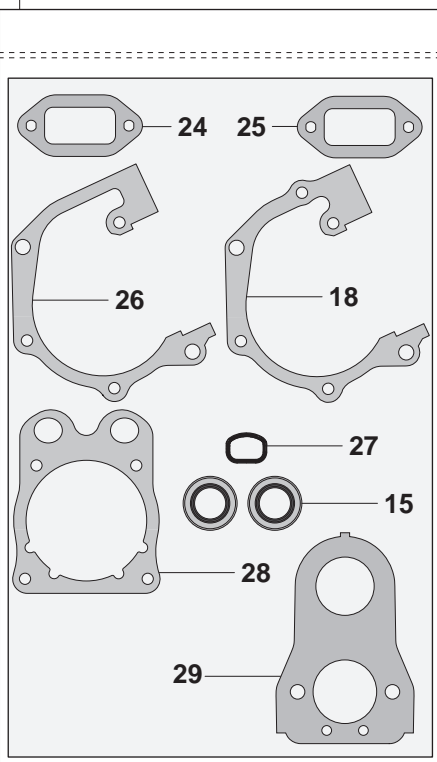
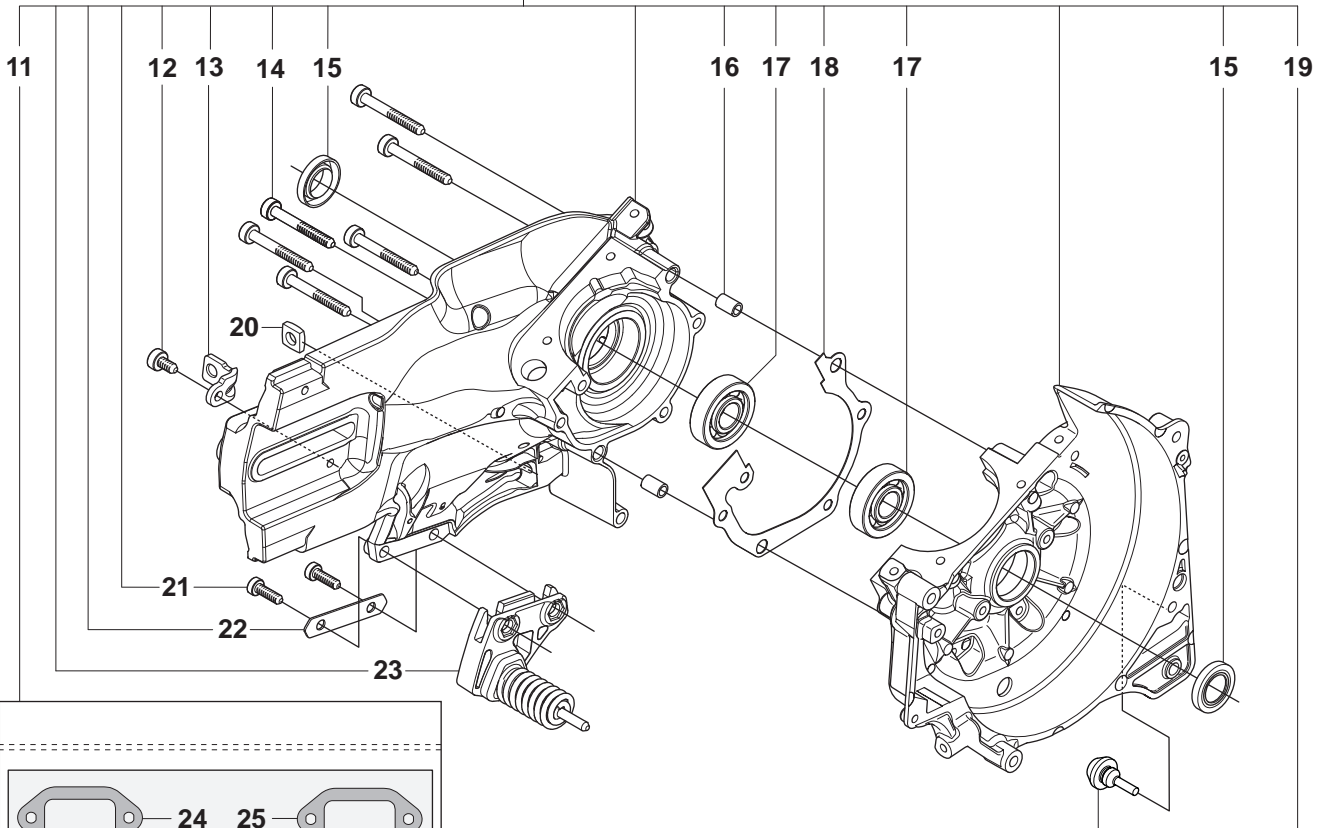
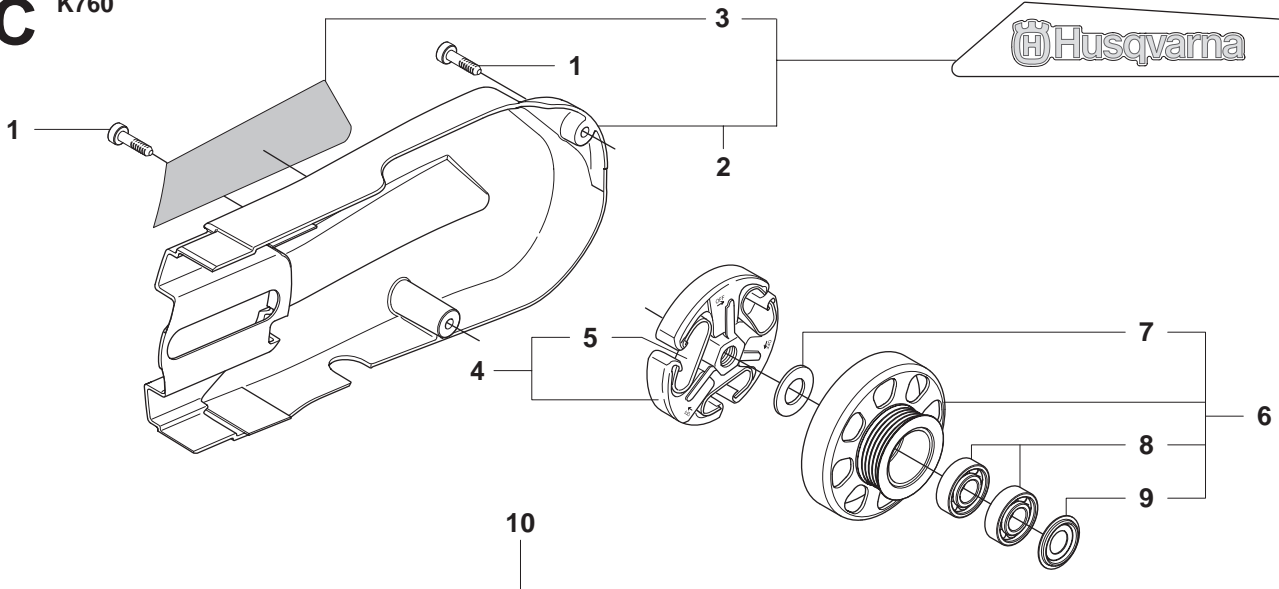

**Page C**  
**K760**

Pos.	Part No.	Description	Quantity	Notes	New Part
1	501 98 10-20	SCREW	2		
2	522 98 08-01	BELT GUARD	1	Incl. 3	
3	544 89 11-01	LABEL	1		
4	503 74 44-06	CLUTCH ASSY	1	Incl. 5	
5	503 74 43-01	CLUTCH SPRING	3		
6	502 28 92-02	DRIVING PULLEY ASSY	1	Incl. 7 - 9	
7	503 23 00-70	WASHER STEEL	1		
8	525 83 18-01	BALL BEARING	2		
9	506 31 69-01	DUST COVER	1		
10	574 36 41-01	CRANKCASE ASSY	1	Incl. 11 - 19, 21 - 23	
11	506 38 53-05	GASKET KIT	1	Incl. 15, 18, 24 - 29	
12	501 98 10-01	SCREW	1		
13	544 00 78-01	BRACKET	1		
14	503 21 53-41	SCREW	6		
15	503 26 02-04	SEALING RING	2		
16	501 27 08-01	GUIDE BUSHING	2		
17	738 22 02-25	BALL BEARING	2		
18	506 37 70-03	GASKET CRANKCASE	1		
19	503 84 61-01	BUFFER	1		
20	503 22 65-04	NUT	1		
21	503 21 53-16	SCREW	2		
22	522 47 48-01	WASHER	1		New Part
23	522 47 57-01	SPRING RETAINER	1		
24	506 41 23-01	GASKET	1		
25	506 37 69-02	GASKET MUFFLER	1		
26	506 37 70-02	GASKET CRANKCASE	1		
27	544 21 93-02	INSERT	1		
28	506 37 67-01	CYLINDER BASE GASKET	1		
29	506 37 68-03	GASKET CARBURETTOR	1		

**D** K760

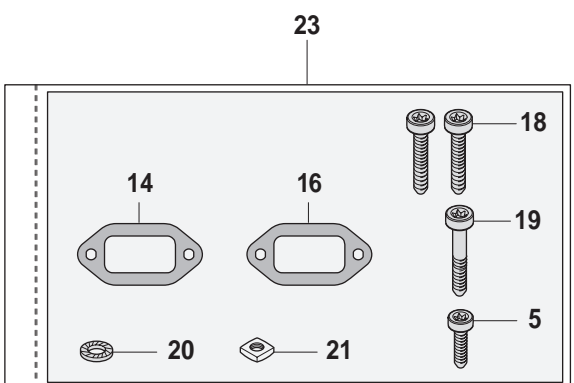
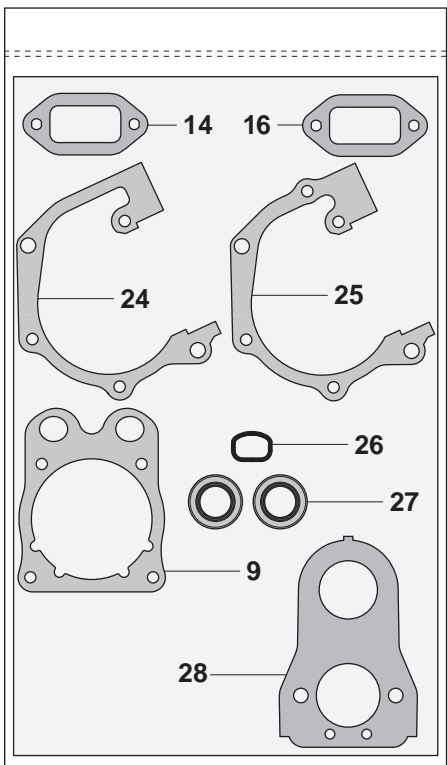
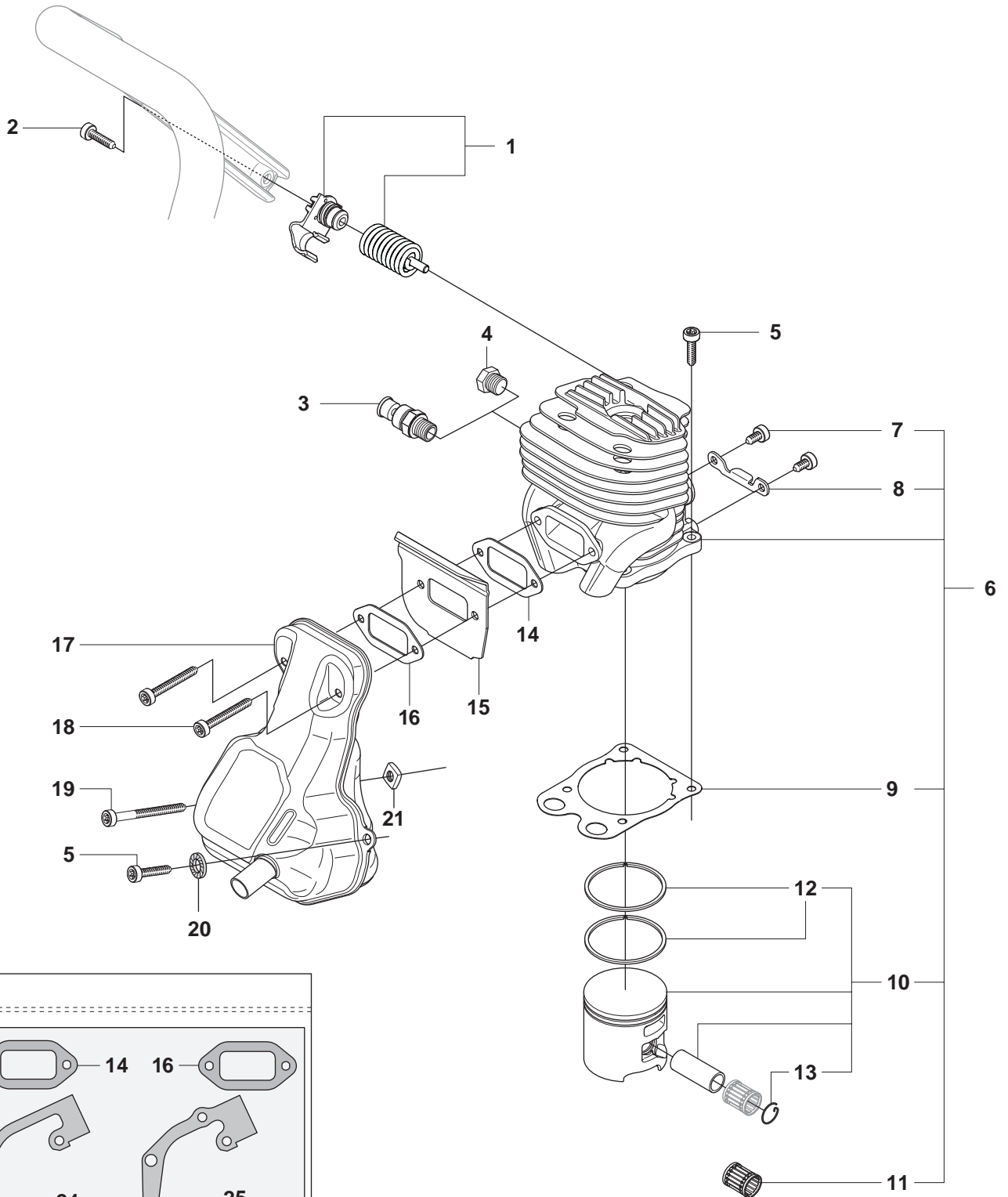



**Page D**  
**K760**

Pos.	Part No.	Description	Quantity	Notes	New Part
1	505 42 45-01	VIB.INSULATOR	1		
2	544 06 12-01	SCREW	1		
3	503 71 53-01	DECOMPRESSION VALVE	1		
4	503 55 22-01	PLUG	1		
5	503 21 53-25	SCREW	5		
6	520 75 73-04	CYLINDER ASSY	1	Incl. 7 - 11	
7	503 21 53-16	SCREW	2		
8	506 36 88-01	BRACKET	1		
9	506 37 67-01	CYLINDER BASE GASKET	1		
10	506 37 24-01	PISTON ASSY	1	Incl. 12 - 13	
11	503 25 56-01	NEEDLE BEARING	1		
12	503 28 90-47	PISTON RING	2		
13	737 43 12-00	CIRCLIP	2		
14	506 41 23-01	GASKET	1		
15	506 37 58-02	COOLING PLATE	1		
16	506 37 69-02	GASKET MUFFLER	1		
17	506 36 42-04	MUFFLER	1		
18	503 21 53-40	SCREW	2		
19	503 21 53-56	SCREW	1		
20	503 23 04-02	WASHER	1		
21	503 22 65-04	NUT	1		
22	506 38 53-05	GASKET KIT	1	Incl. 9, 14, 16, 24 - 28	
23	505 25 96-01	MUFFLER MOUNTING KIT	1	Incl. 5, 14, 16, 18 - 21	
24	506 37 70-02	GASKET CRANKCASE	1		
25	506 37 70-03	GASKET CRANKCASE	1		
26	544 21 93-02	INSERT	1		
27	503 26 02-04	SEALING RING	2		
28	506 37 68-03	GASKET CARBURETTOR	1		

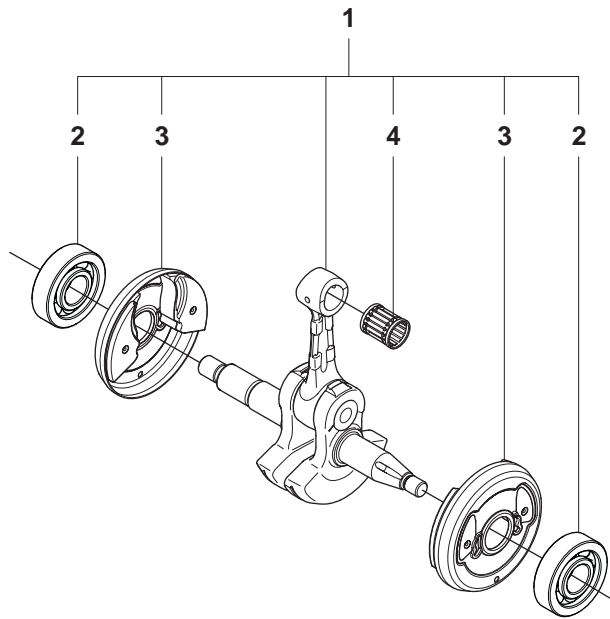

**Page E**  
**K760**

<b>Pos.</b>	<b>Part No.</b>	<b>Description</b>	<b>Quantity</b>	<b>Notes</b>	<b>New Part</b>
1	502 29 50-02	CRANKSHAFT ASSY	1	Incl. 2 - 4	
2	738 22 02-25	BALL BEARING	2		
3	537 20 33-01	CUP	2		
4	503 25 56-01	NEEDLE BEARING	1		

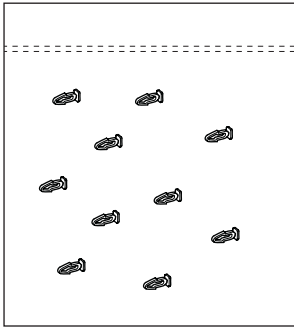

41 C

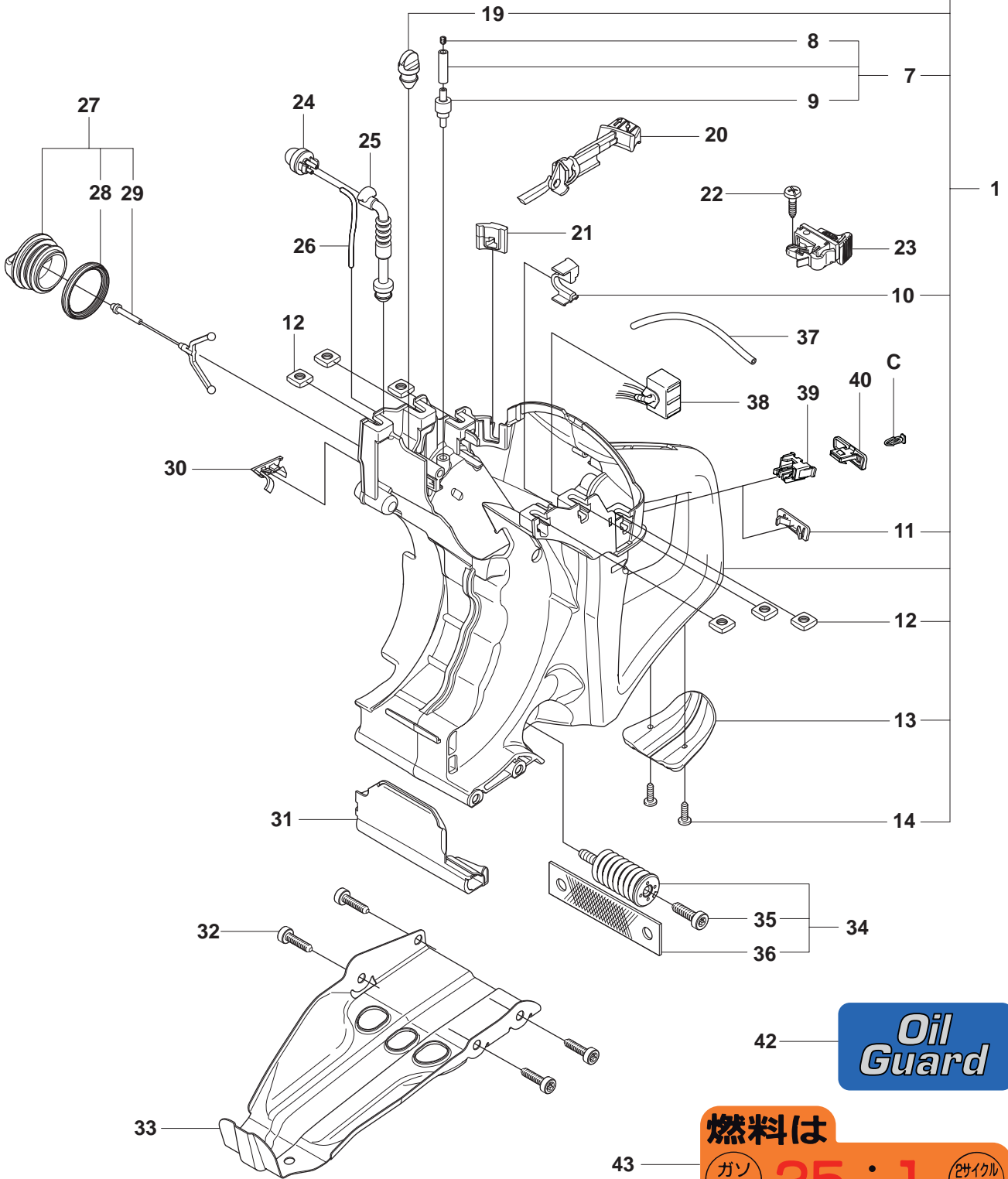
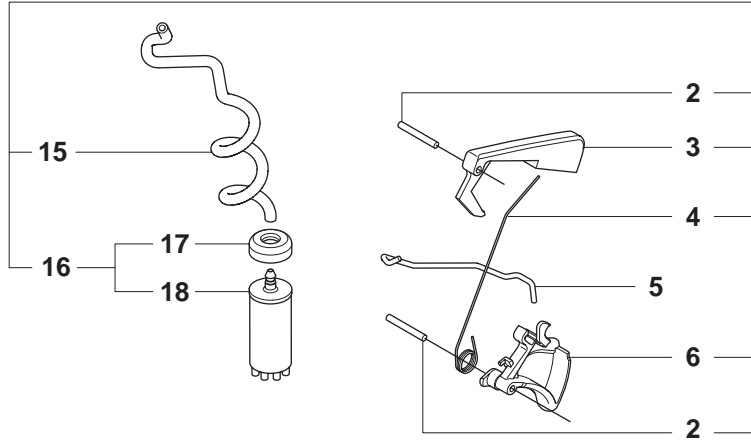

**燃料は**  
**ガソリン 25 : 1**  
2サイクル専用オイル

43

**Page F**  
**K760**

Pos.	Part No.	Description	Quantity	Notes	New Part
1	506 38 65-13	FUEL TANK	1	Incl. 2 - 4, 6 - 7, 10 - 16	New Part
2	720 12 40-20	PARALLEL PIN	2		
3	506 22 28-02	THROTTLE LOCKOUT	1		
4	506 37 95-01	SPRING	1		
5	506 37 13-01	THROTTLE ROD	1		
6	506 37 20-03	THROTTLE TRIGGER	1		
7	506 38 66-01	TANK VENT ASSY	1	Incl. 8 - 9	
8	504 35 72-01	SINTER PLUG	1		
9	503 16 40-01	TANK VENT	1		
10	544 39 32-01	HOSE CLIP	1		
11	501 37 13-01	LID	1		
12	503 22 65-04	NUT	6		
13	506 38 67-02	GROUND SUPPORT	1		
14	503 21 45-16	SCREW	2		
15	544 32 50-03	FUEL HOSE	1		
16	506 26 41-11	FUEL FILTER	1	Incl. 17 - 18	
17	506 27 11-01	HOSE CLAMP	1		
18	506 26 41-01	FUEL FILTER	1		
19	574 40 57-01	SEALING PLUG	1		New Part
20	544 22 90-02	CHOKE CONTROL	1		
21	506 37 80-01	GROMMET	1		
22	503 21 28-10	SCREW	1		
23	506 31 86-02	STOP SWITCH	1		
24	503 93 66-01	PRIMER HOUSING	1	Purge	
25	505 19 52-01	FUEL HOSE	1	Purge	
26	537 04 24-14	FUEL HOSE	1	Purge	
27	506 25 59-03	TANK CAP ASSY	1	Incl. 28 - 29	
28	506 29 21-01	GASKET	1		
29	503 57 89-01	TANK CAP HOLDER	1		
30	506 39 46-02	CAP	1		
31	506 38 15-01	HEAT SHIELD	1		
32	503 21 54-20	SCREW	4		
33	506 37 19-02	BASE PLATE	1		
34	537 21 03-07	VIBRATION ABSORBER	1	Incl. 35 - 36	
35	544 06 12-01	SCREW	1		
36	544 23 82-01	BAND	1		
37	544 32 49-37	FUEL HOSE	1	Oil Guard	
38	544 38 41-01	ELECTRONIC BOX	1	Oil Guard	
39	501 01 88-01	HOUSING	1	Oil Guard	
40	501 01 94-01	SWITCH	1	Oil Guard	
41	502 23 33-01	KIT BREAK PIN	1	Oil Guard, Incl. 10 pins	
42	501 31 89-01	LABEL	1	Oil Guard	

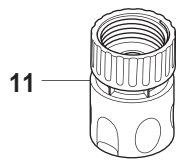
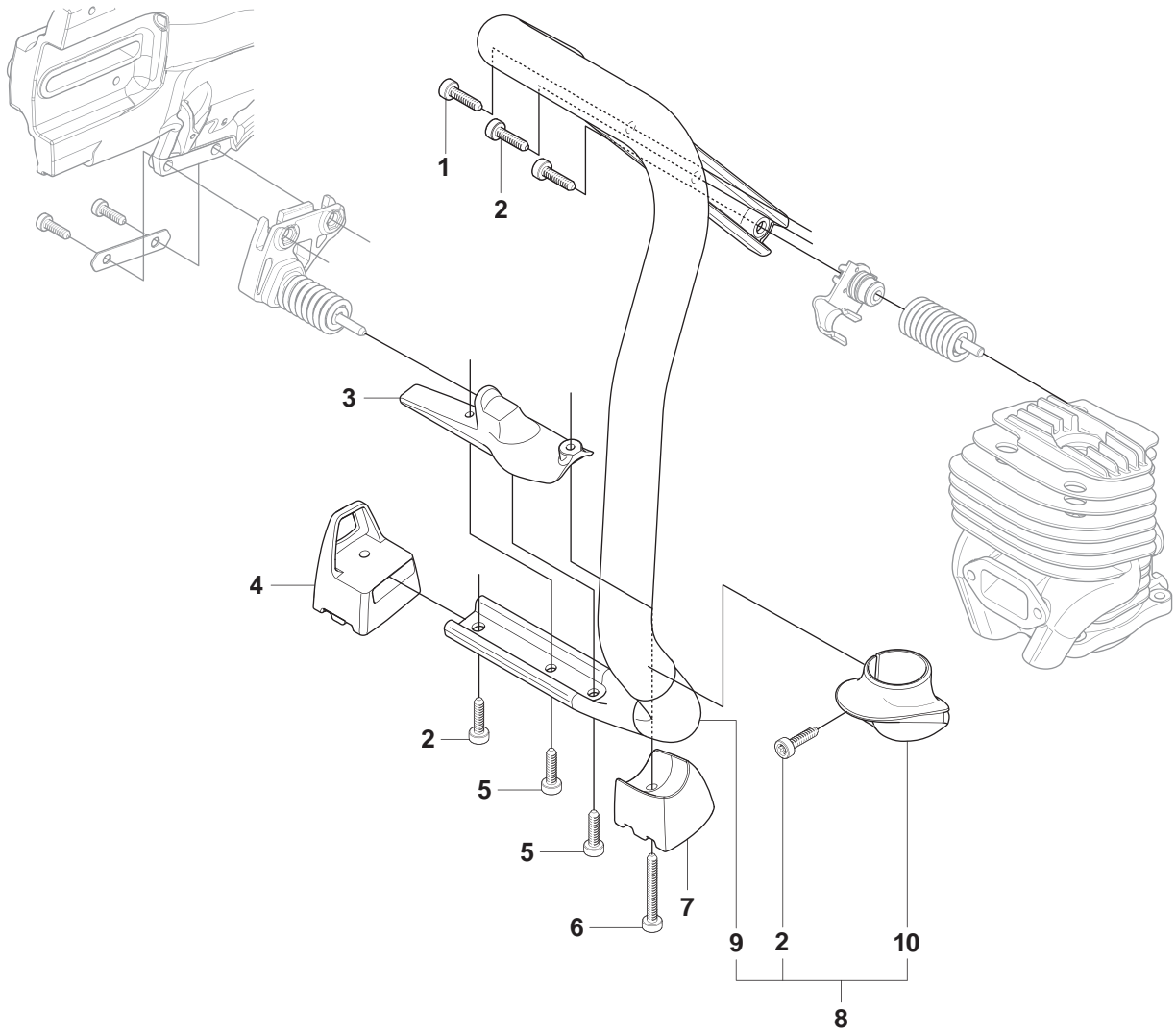

12

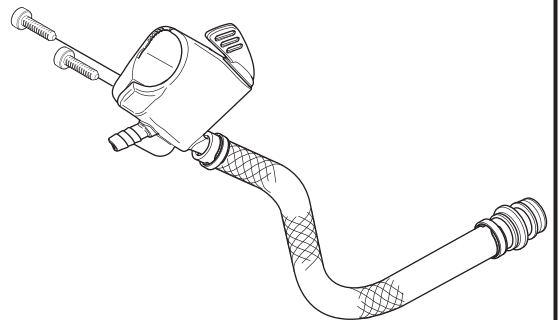

**Page G**  
**K760**

<b>Pos.</b>	<b>Part No.</b>	<b>Description</b>	<b>Quantity</b>	<b>Notes</b>	<b>New Part</b>
1	544 06 12-01	SCREW	3		
2	503 21 54-20	SCREW	4		
3	506 37 72-02	SPRING RETAINER	1		
4	522 83 23-01	GROUND SUPPORT	1		
5	503 21 53-10	SCREW	2		
6	503 21 53-40	SCREW	1		
7	522 83 24-01	GROUND SUPPORT	1		
8	506 38 58-04	HANDLE	1	Incl. 4, 9-10	
9	506 37 11-03	FRONT HANDLE	1		
10	506 38 71-02	STOP	1		
11	503 26 60-03	COUPLER	1	USA, Canada	
11	503 26 60-04	COUPLER	1		
12	505 09 55-01	HOSE KIT	1		

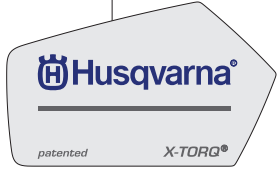
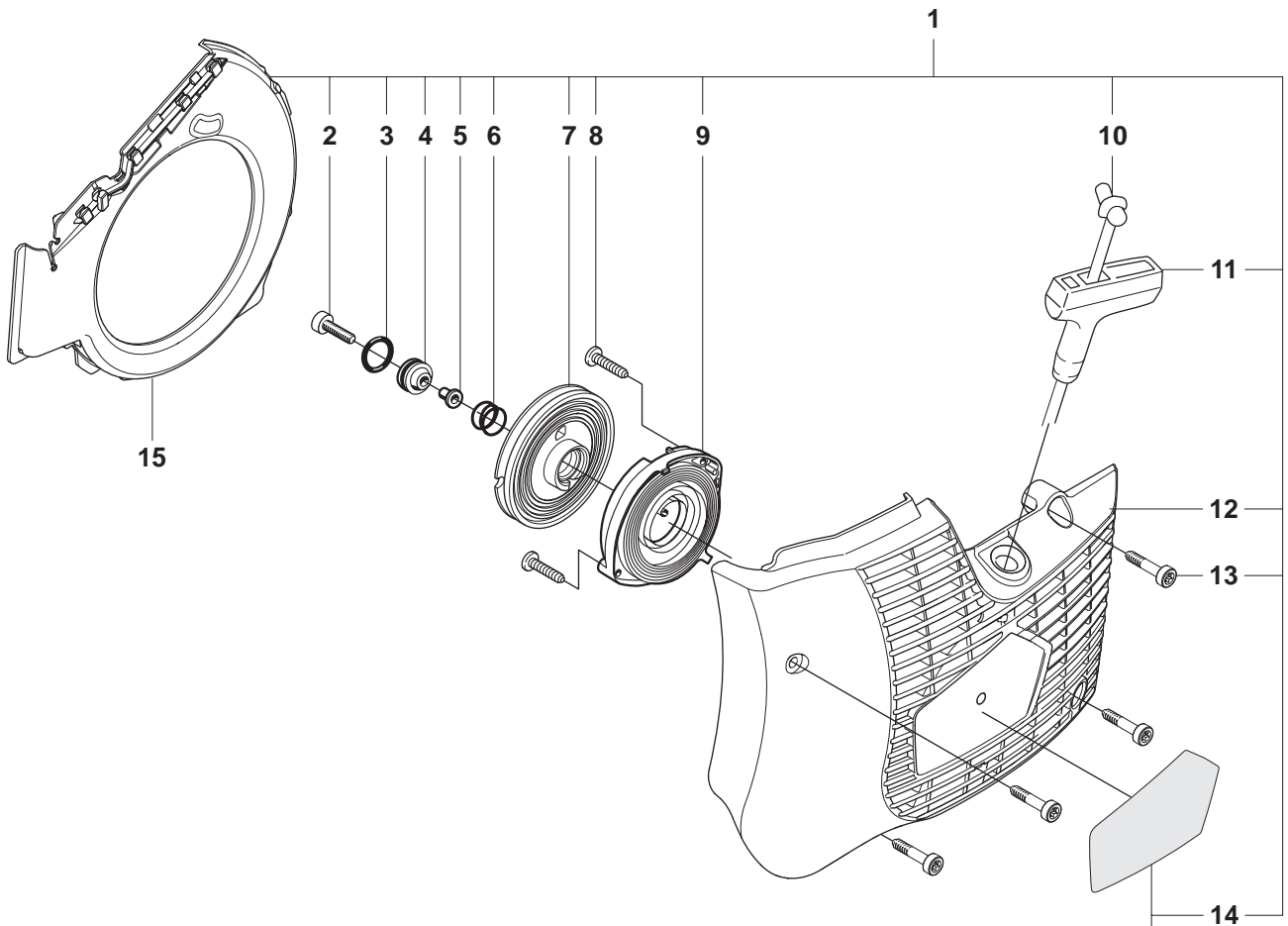



**Page H**  
**K760**

<b>Pos.</b>	<b>Part No.</b>	<b>Description</b>	<b>Quantity</b>	<b>Notes</b>	<b>New Part</b>
1	574 36 20-01	STARTER	1	Incl. 2 - 15	
2	510 26 92-22	SCREW	1		
3	740 43 13-00	O-RING	1		
4	510 00 08-01	SEALING HOLDER	1		
5	506 26 31-01	SPACING SLEEVE	1		
6	506 25 30-01	COMPRESSION SPRING	1		
7	506 25 81-02	STARTER PULLEY	1		
8	503 21 28-10	SCREW	2		
9	506 25 89-01	RECOIL SPRING	1		
10	506 33 56-15	STARTER CORD	1		
10	506 33 56-50	STARTER CORD	1	50 m	
11	503 12 79-01	STARTER HANDLE	1		
12	525 44 60-01	STARTER COVER	1		
13	501 98 10-20	SCREW	4		
14	525 57 11-01	LABEL	1		
15	544 38 39-01	AIR CONDUCTOR	1		

**J** K760

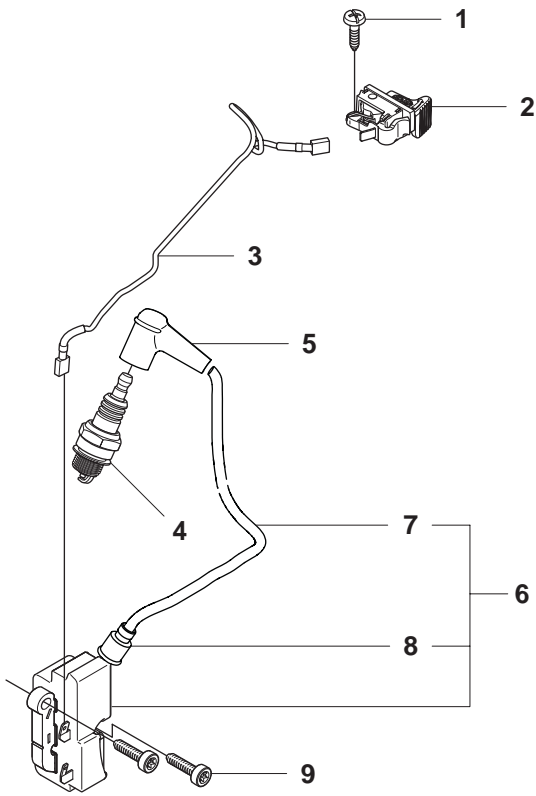

K760 Oil Guard

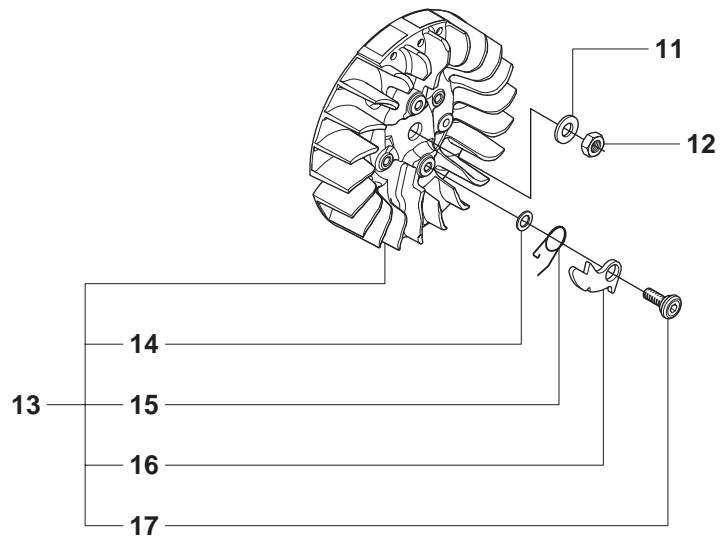
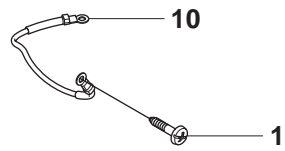
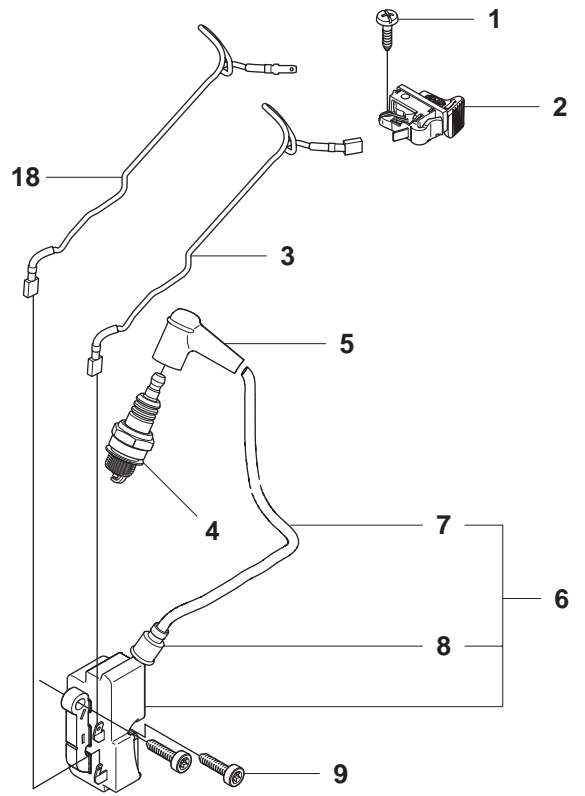

**Page J**  
**K760**

<b>Pos.</b>	<b>Part No.</b>	<b>Description</b>	<b>Quantity</b>	<b>Notes</b>	<b>New Part</b>
1	503 21 28-10	SCREW	2		
2	506 31 86-02	STOP SWITCH	1		
3	506 37 84-02	CABLE	1		
3	544 97 93-01	CABLE	1	Oil Guard	
4	503 23 51-09	SPARK PLUG	1	RCJ 6 Y	
5	501 48 54-02	SPARK PLUG CAP	1		
6	510 11 56-01	IGNITION MODULE	1	Incl. 7 - 8	New Part
7	506 38 78-34	IGNITION CABLE	1		
8	505 27 75-16	ISOLERHATT	1		
9	503 21 53-20	SCREW	2		
10	506 37 85-01	CABLE	1		
11	503 23 01-01	WASHER STEEL	1		
12	503 22 10-11	NUT	1		
13	501 37 56-01	FLYWHEEL	1	Incl. 14 - 17	
14	503 23 00-42	WASHER STEEL	2		
15	501 63 48-01	SPRING	2		
16	501 67 32-03	PAWL	2		
17	506 00 69-01	SCREW	2		
18	544 38 49-01	CABLE	1	Oil Guard	

# K K760

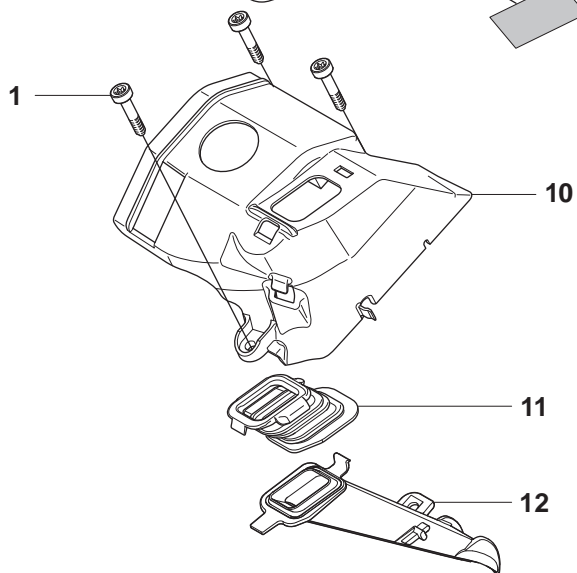
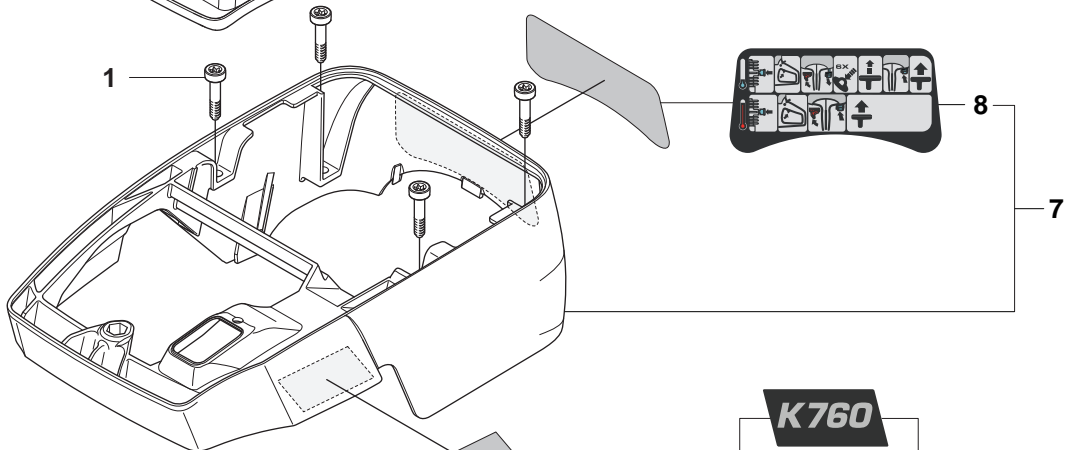
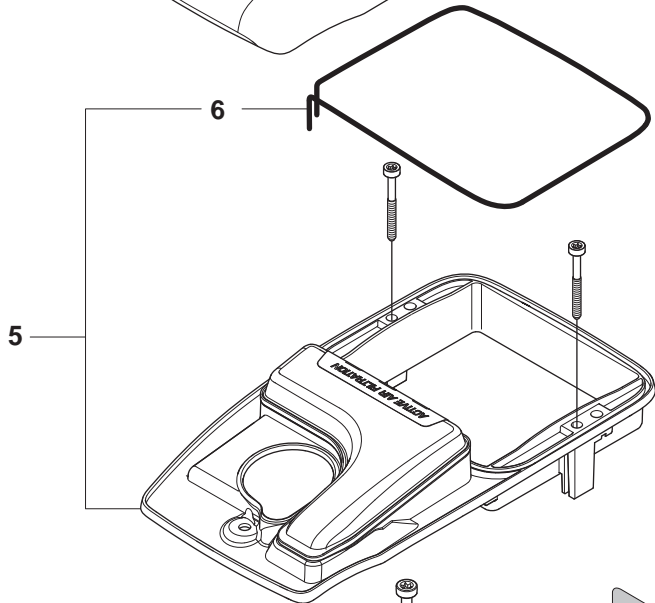
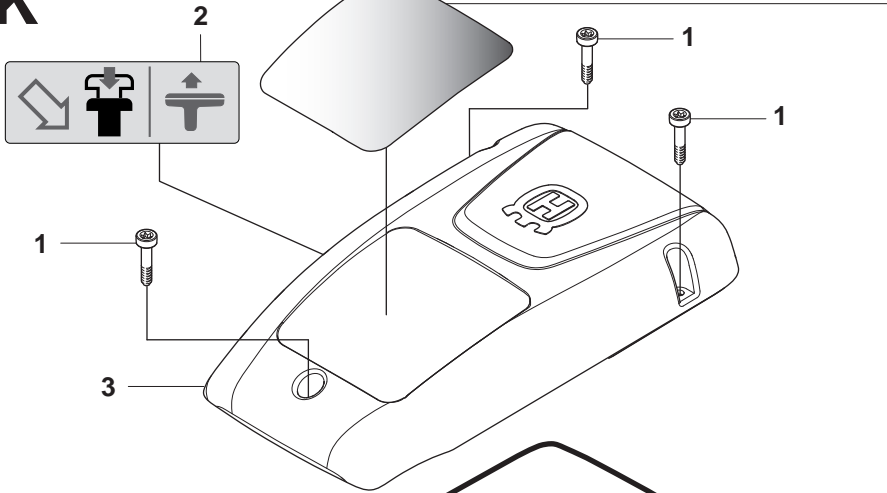

**⚠ WARNING ⚠**  
**⚠ Cutters can be dangerous! ⚠**

For safe operations, operators must follow all safety procedures in the Operator's Manual. Only persons who have been instructed in the use of this cutter and who are familiar with all safety procedures in the Operator's Manual should operate the cutter. The cutter can cause serious injury. Use only designed or approved cutting equipment approved for intended cutting on high speed cutters. Use personal protective equipment as outlined in the Operator's Manual. Pay special attention to eye protection and hearing noise. Operation of this equipment may create sparks that can start fires around dry vegetation. A spark arrester may be required. The operator should avoid fuel line sprays for fuel or fuel vapors nearby in the presence of fire.

**OPERATIONS PERMITTED:** USE ONLY DESIGNED OR APPROVED CUTTING EQUIPMENT FOR INTENDED CUTTING ON HIGH SPEED CUTTERS. USE PERSONAL PROTECTIVE EQUIPMENT AS OUTLINED IN THE OPERATOR'S MANUAL. PAY SPECIAL ATTENTION TO EYE PROTECTION AND HEARING NOISE.

**OPERATIONS PROHIBITED:** DO NOT OPERATE THIS EQUIPMENT ON DRY VEGETATION. A SPARK ARRESTER MAY BE REQUIRED. THE OPERATOR SHOULD AVOID FUEL LINE SPRAYS FOR FUEL OR FUEL VAPORS NEARBY IN THE PRESENCE OF FIRE.

REGULATORY COMPLIANCE: CANADA, U.S.A., EUROPE, MEXICO, CHINA, INDIA, AUSTRALIA, SOUTH AFRICA, BRAZIL, ARGENTINA, COLOMBIA, PERU, VENEZUELA, GUATEMALA, COSTA RICA, PANAMA, DOMINICAN REPUBLIC, HONDURAS, NICARAGUA, EL SALVADOR, GUINEA-BISSAU, MALI, BURKINA FASO, SENEGAL, GUINEA, SIERRA LEONE, LIBERIA, COTE D'IVOIRE, GABON, CONGO, ANGOLA, ZAMBIA, ZIMBABWE, BOTSWANA, SWAZILAND, LESOTHO, MALAWI, MOZAMBIQUE, TANZANIA, ZAMBIA, ZIMBABWE, BOTSWANA, SWAZILAND, LESOTHO, MALAWI, MOZAMBIQUE, TANZANIA.

**⚠ WARNING ⚠**

**⚠ Cutters can be dangerous! ⚠**

**OPERATIONS PERMITTED:** USE ONLY DESIGNED OR APPROVED CUTTING EQUIPMENT FOR INTENDED CUTTING ON HIGH SPEED CUTTERS. USE PERSONAL PROTECTIVE EQUIPMENT AS OUTLINED IN THE OPERATOR'S MANUAL. PAY SPECIAL ATTENTION TO EYE PROTECTION AND HEARING NOISE.

**OPERATIONS PROHIBITED:** DO NOT OPERATE THIS EQUIPMENT ON DRY VEGETATION. A SPARK ARRESTER MAY BE REQUIRED. THE OPERATOR SHOULD AVOID FUEL LINE SPRAYS FOR FUEL OR FUEL VAPORS NEARBY IN THE PRESENCE OF FIRE.

REGULATORY COMPLIANCE: CANADA, U.S.A., EUROPE, MEXICO, CHINA, INDIA, AUSTRALIA, SOUTH AFRICA, BRAZIL, ARGENTINA, COLOMBIA, PERU, VENEZUELA, GUATEMALA, COSTA RICA, PANAMA, DOMINICAN REPUBLIC, HONDURAS, NICARAGUA, EL SALVADOR, GUINEA-BISSAU, MALI, BURKINA FASO, SENEGAL, GUINEA, SIERRA LEONE, LIBERIA, COTE D'IVOIRE, GABON, CONGO, ANGOLA, ZAMBIA, ZIMBABWE, BOTSWANA, SWAZILAND, LESOTHO, MALAWI, MOZAMBIQUE, TANZANIA.

- K760**
- K760 RESCUE**
- K760 OilGuard**

**Page K**  
**K760**

<b>Pos.</b>	<b>Part No.</b>	<b>Description</b>	<b>Quantity</b>	<b>Notes</b>	<b>New Part</b>
1	503 21 53-21	SCREW	10		
2	525 76 35-02	DECAL	1		
3	525 44 43-01	FILTER COVER	1		
4	574 23 14-01	DECAL	1	EPA USA	
4	574 23 14-02	DECAL	1	CE, EPA Canada	
5	574 36 21-01	FILTER HOLDER ASSY	1	Incl. 6	
6	575 35 50-01	SEALING	1		New Part
7	506 39 84-05	CYLINDER COVER ASSY	1	Incl. 8	
8	544 89 09-02	LABEL	1		
9	574 23 16-01	DECAL	1		
9	574 23 16-02	DECAL	1	Rescue	
9	574 23 16-03	DECAL	1	Oil Guard	
10	506 37 02-01	COVER	1	Incl. 12, 13	
11	506 37 04-01	BELLOWS	1		
12	525 58 43-01	AIR NOZZLE	1		



K760

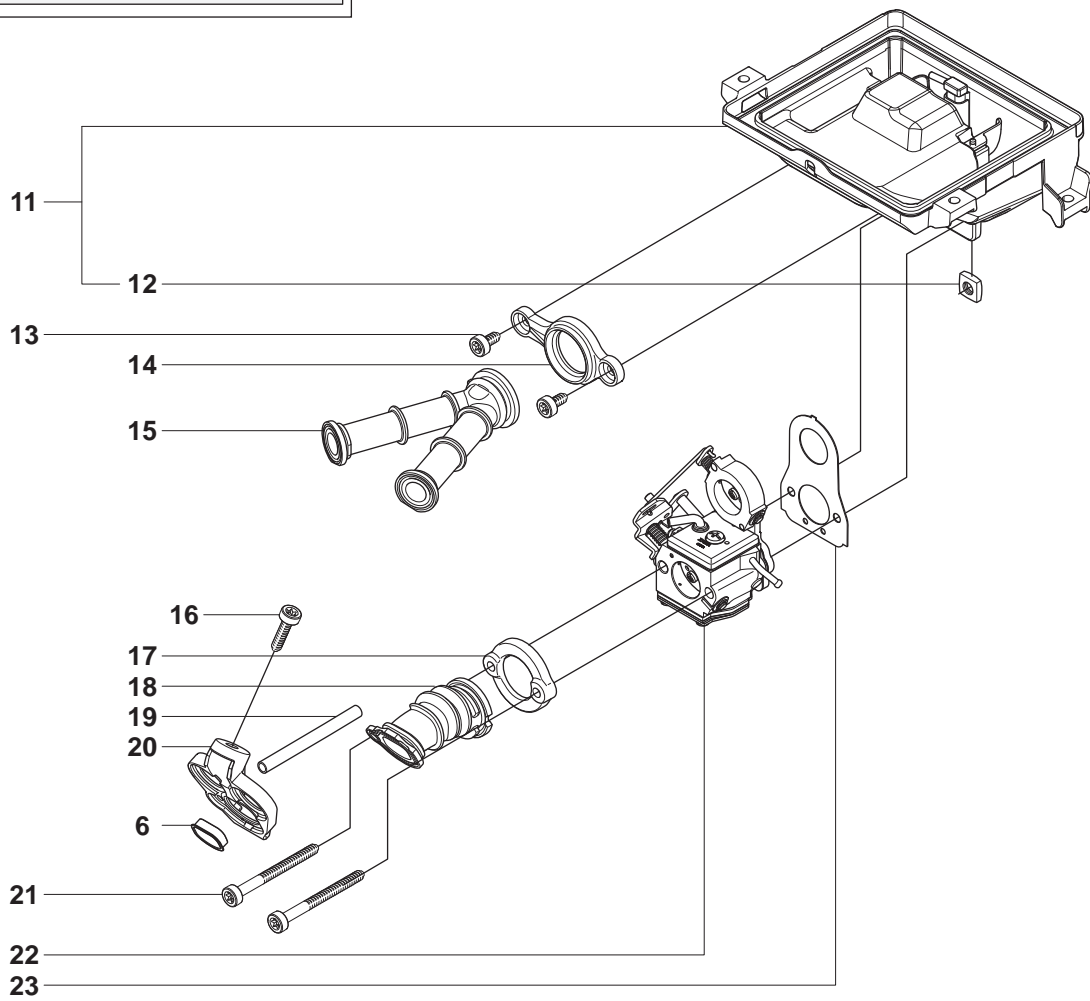
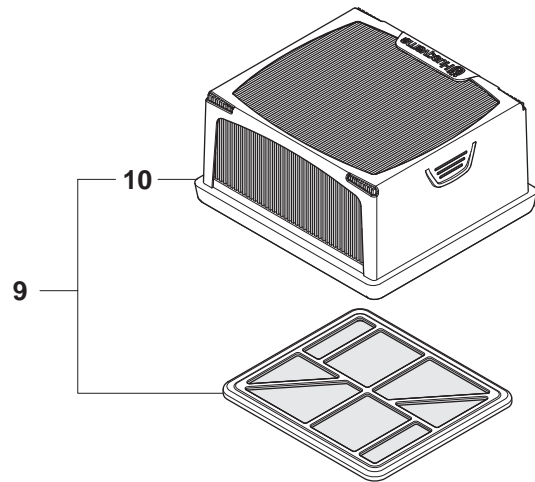
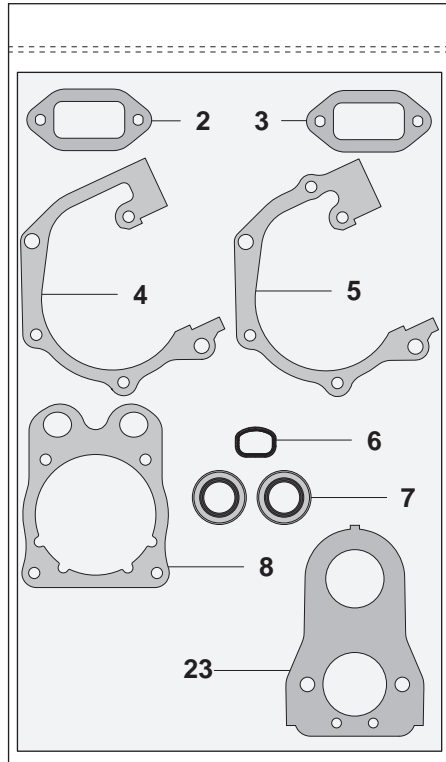

**Page L**  
**K760**

<b>Pos.</b>	<b>Part No.</b>	<b>Description</b>	<b>Quantity</b>	<b>Notes</b>	<b>New Part</b>
1	506 38 53-05	GASKET KIT	1	Incl. 2 - 8, 23	
2	506 41 23-01	GASKET	1		
3	506 37 69-02	GASKET MUFFLER	1		
4	506 37 70-02	GASKET CRANKCASE	1		
5	506 37 70-03	GASKET CRANKCASE	1		
6	544 21 93-02	INSERT	1		
7	503 26 02-04	SEALING RING	2		
8	506 37 67-01	CYLINDER BASE GASKET	1		
9	574 36 23-01	FILTER	1	Incl. 10	
10	525 47 06-01	AIR FILTER PAPER	1		
11	575 35 40-01	CARBURETTOR BRACKET	1	Incl. 12	
12	503 22 65-04	NUT	4		
13	503 21 53-10	SCREW	2		
14	506 37 06-01	FLANGE INLET PIPE	1		
15	506 36 98-01	INLET PIPE	1		
16	503 21 53-20	SCREW	1		
17	506 37 05-01	FLANGE INLET PIPE	1		
18	506 36 97-01	INLET PIPE	1		
19	503 40 06-09	IMPULSE HOSE	1		
20	544 35 26-01	PLATE	1		
21	503 21 53-56	SCREW	2		
22	510 18 12-02	CARBURETTOR	1	Zama C3-EL43A	
23	506 37 68-03	GASKET CARBURETTOR	1		

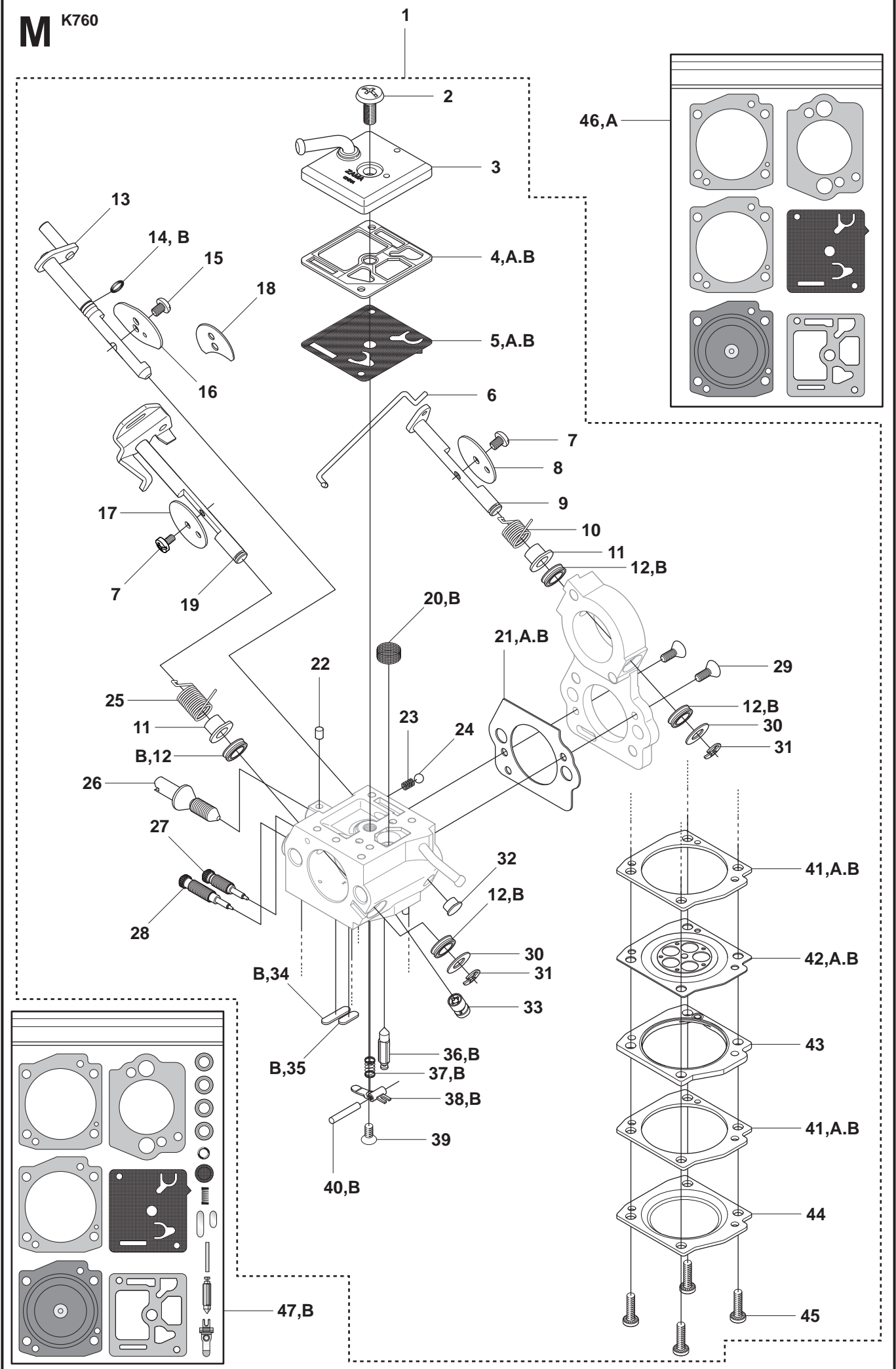



**Page M**

**K760**

Pos.	Part No.	Description	Quantity	Notes	New Part
1	510 18 12-02	CARBURETTOR	1	Zama C3-EL43A, Incl. 2 - 43	
2	503 47 96-01	SCREW	1		
3	544 83 64-01	PUMP COVER	1		
4	503 61 66-01	GASKET PUMP	1		
5	506 39 60-01	DIAPHRAGM PUMP	1		
6	506 39 65-01	ROD	1		
7	544 08 22-01	SCREW	2		
9	506 39 71-01	SHAFT ASSY	1		
10	506 39 75-01	SPRING	1		
11	506 39 54-01	COLLAR	2		
12	506 39 64-01	QUAD RING	4		
13	506 39 73-01	SHAFT ASSY CHOKE	1		
14	506 39 90-01	O-RING	1		
15	503 48 18-01	SCREW	1		
16	506 39 78-01	VALVE	1		
17	537 17 70-01	VALVE	1		
19	506 39 74-01	SHAFT ASSY	1		
20	503 53 57-01	STRAINER	1		
21	506 39 58-01	GASKET	1		
22	503 48 11-01	PIECE	1		
23	537 01 26-01	SPRING	1		
24	537 01 25-01	BALL	1		
25	544 83 65-01	SPRING	1		
26	506 39 72-01	SCREW	1		
27	506 39 70-01	SCREW	1		
28	506 39 69-01	SCREW	1		
29	537 38 51-01	SCREW	2		
30	506 39 79-01	WASHER	2		
31	537 38 52-01	E-CLIP	2		
32	506 39 91-01	PLUG	1		
33	506 39 61-01	NOZZLE ASSY	1		
34	503 53 56-01	PLUG WELCH	1		
35	537 17 78-01	PLUG	1		
36	537 17 62-01	VALVE	1		
37	575 44 13-01	SPRING	1		
38	537 17 64-01	LEVER	1		
39	544 08 21-01	SCREW	1		
40	503 48 00-01	PIN RETAINING SCREW	1		
41	506 39 62-01	GASKET	2		
42	506 39 57-01	DIAPHRAGM ASSY	1		
43	506 39 55-01	COVER	1		
44	506 39 56-01	COVER	1		
45	506 39 66-01	SCREW	4		
46	506 40 99-01	GASKET KIT	1	Incl. 4-5, 21, 41, 42	
47	506 41 00-03	GASKET KIT CARB	1	Incl. 4-5, 12, 14, 20, 21, 34-38, 40-42	

**N** K760

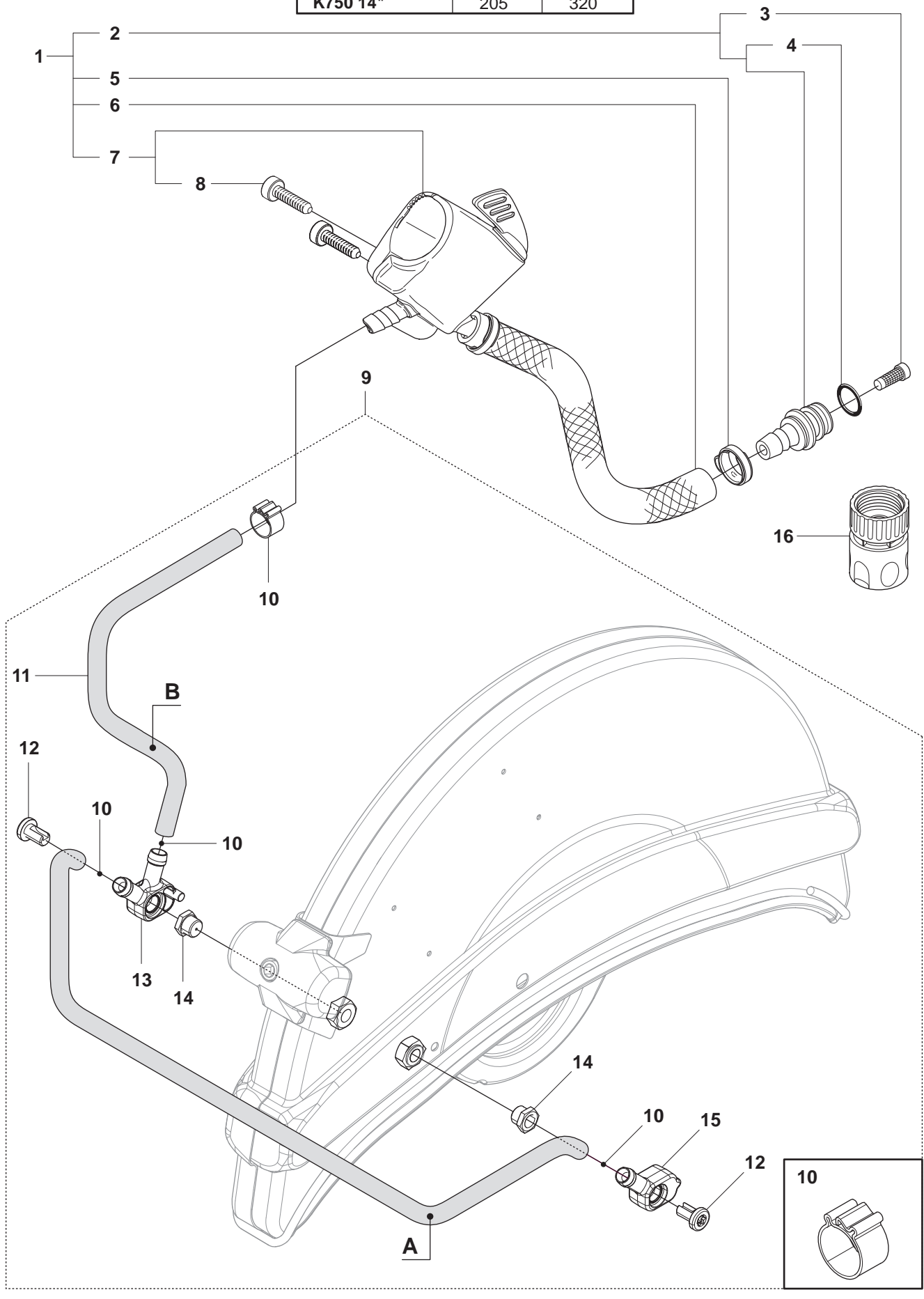
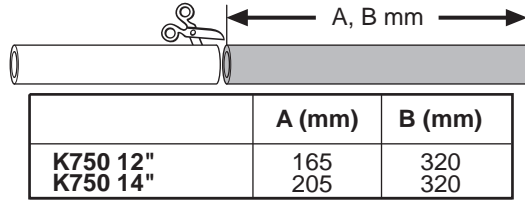

**Page N**  
**K760**

<b>Pos.</b>	<b>Part No.</b>	<b>Description</b>	<b>Quantity</b>	<b>Notes</b>	<b>New Part</b>
1	505 09 55-01	HOSE KIT	1	Incl. 2, 5 - 7	
2	506 29 57-02	NIPPLE	1	Incl. 3, 4	
3	506 29 88-01	FILTER	1		
4	505 10 35-01	O-RING	1		
5	506 49 87-02	HOSE CLAMP	1		
6	506 60 75-01	HOSE	1		
7	506 38 60-12	VALVE ASSY	1	Incl. 8	
8	503 21 54-20	SCREW	2		
9	505 09 54-01	HOSE KIT	1	Incl. 10 - 15	
10	506 49 87-01	HOSE CLAMP	4		
11	506 60 68-66	HOSE	1	620 mm	
12	504 63 46-01	SCREW	2		
13	504 63 44-01	HOUSING	1		
14	504 63 42-01	NIPPLE	2		
15	504 63 45-01	HOUSING	1		
16	503 26 60-03	COUPLER	1	USA, Canada	
16	503 26 60-04	COUPLER	1		

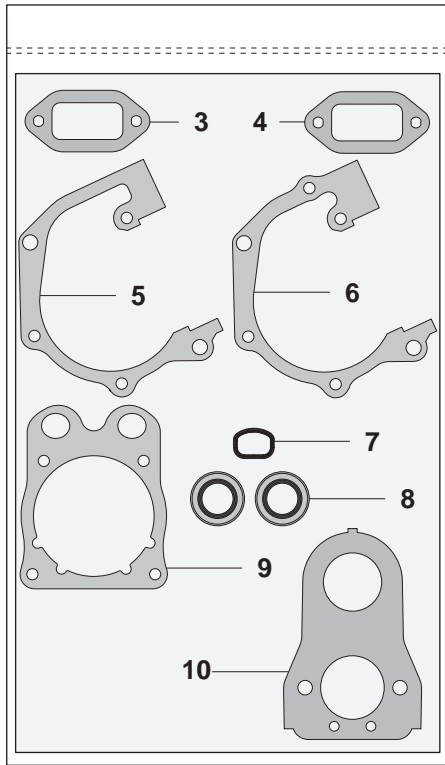

2

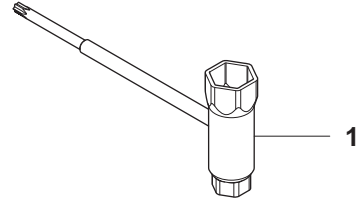

1

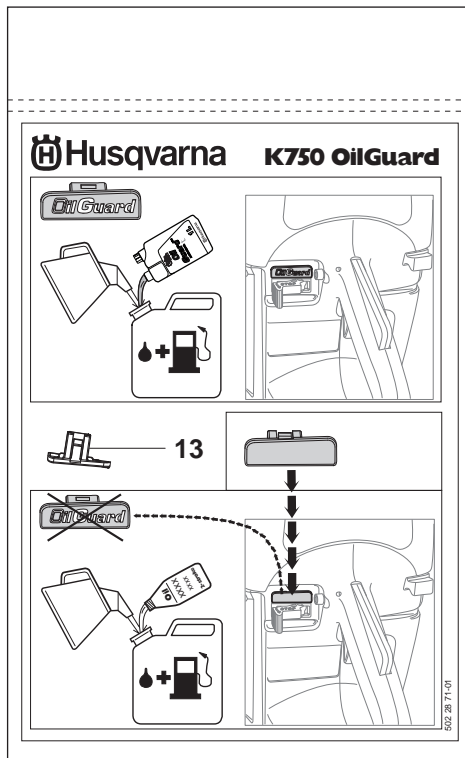

12

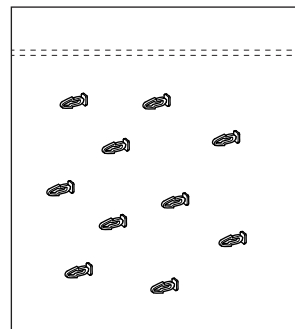

11

**Page P**  
**K760**

<b>Pos.</b>	<b>Part No.</b>	<b>Description</b>	<b>Quantity</b>	<b>Notes</b>	<b>New Part</b>
1	506 38 26-01	COMBINATION TOOL	1		
2	506 38 53-05	GASKET KIT	1	Incl. 3 - 10	
3	506 41 23-01	GASKET	1		
4	506 37 69-02	GASKET MUFFLER	1		
5	506 37 70-02	GASKET CRANKCASE	1		
6	506 37 70-03	GASKET CRANKCASE	1		
7	544 21 93-02	INSERT	1		
8	503 26 02-04	SEALING RING	2		
9	506 37 67-01	CYLINDER BASE GASKET	1		
10	506 37 68-03	GASKET CARBURETTOR	1		
11	502 23 33-01	KIT BREAK PIN	1	Incl. 10 Pins	
12	502 28 70-01	KIT SWITCH OFF	1		
13	501 01 95-01	SWITCH	1		

Q K760

# K12 FD FIRE-RESCUE

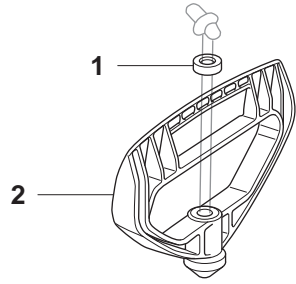

# Rescue

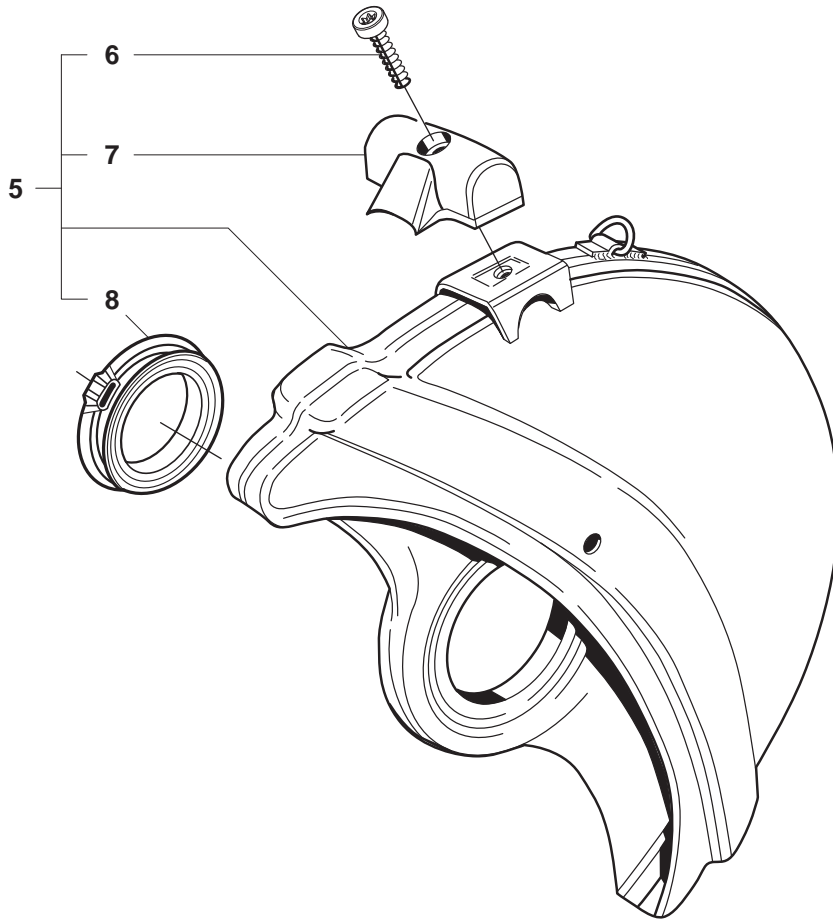

9 — **Husqvarna Rescue**  
max 5100 rpm  
Ø20mm, Ø300mm (Ø12")

10 — **ATTENTION**  
This product has been modified for use by  
trained fire rescue personnel only.

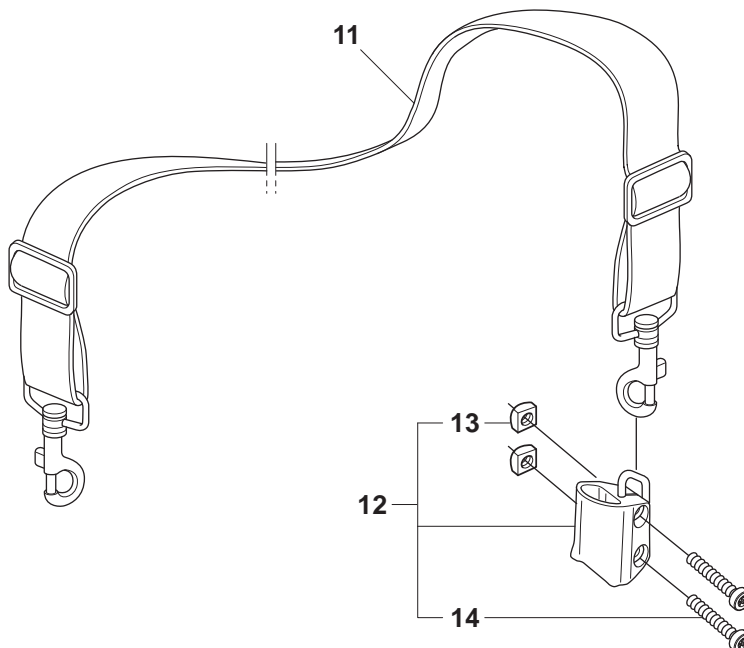

**Page Q**  
**K760**

<b>Pos.</b>	<b>Part No.</b>	<b>Description</b>	<b>Quantity</b>	<b>Notes</b>	<b>New Part</b>
1	503 14 29-02	WASHER	1		
2	506 29 75-02	STARTER HANDLE	1		
3	506 32 20-02	LABEL	1		
4	506 30 23-02	LABEL	2		
5	506 34 05-52	WHEEL GUARD ASSY	1	Rescue 12". Incl. 6 - 8	
6	503 21 53-20	SCREW	1		
7	506 34 46-02	HANDLE	1		
8	506 26 63-02	LINING	2		
9	544 89 06-02	LABEL	1		
10	506 32 22-02	LABEL	1		
11	506 29 76-01	SHOULDER STRAP	1		
12	506 30 25-04	BRACKET	1	Incl. 13, 14	
13	503 22 65-04	NUT	2		
14	503 21 53-16	SCREW	2		

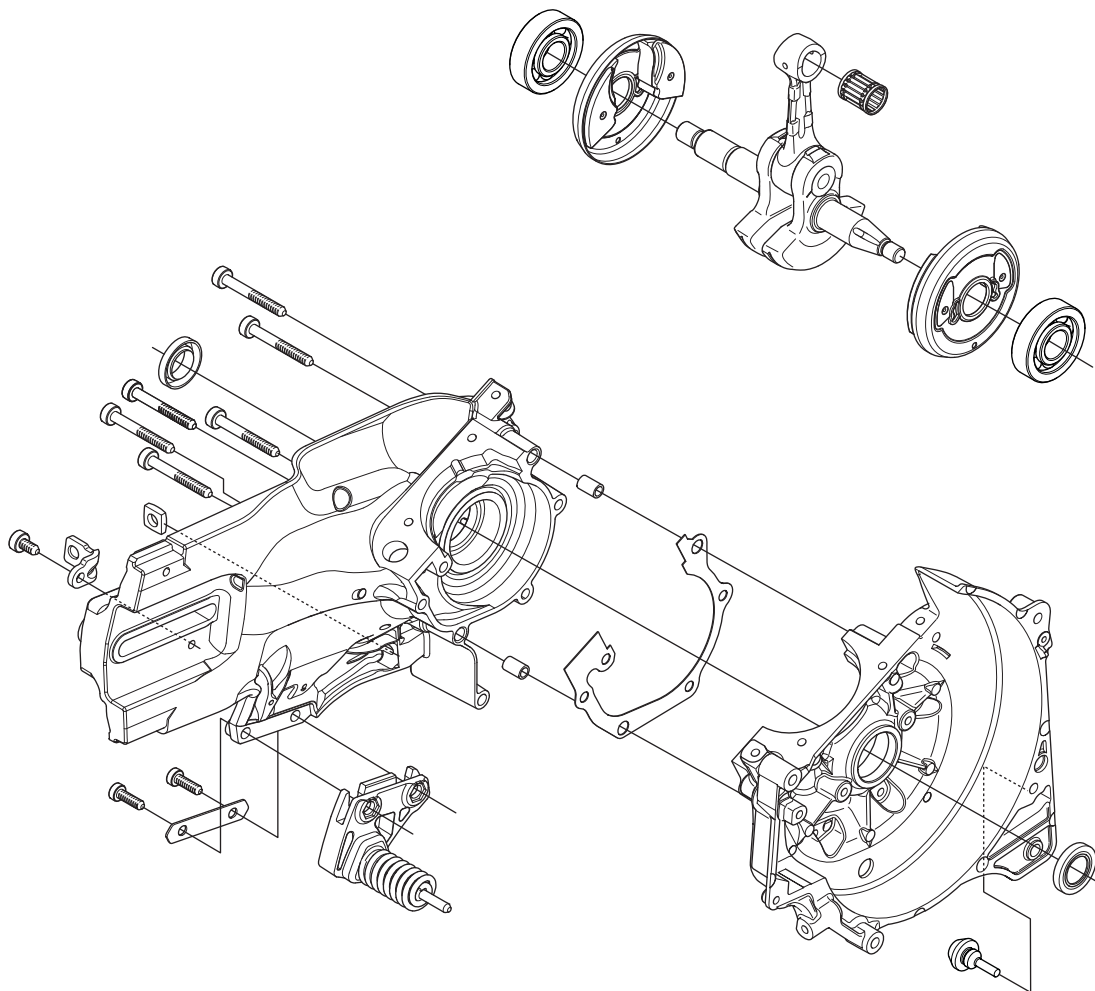
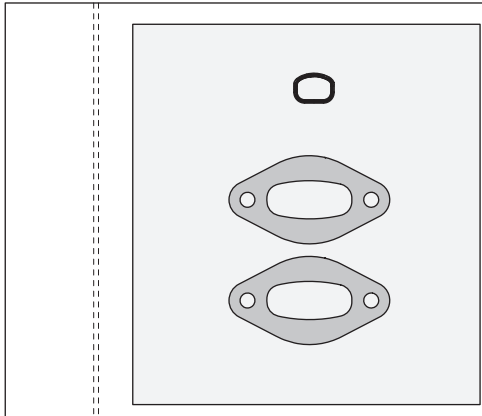



**Page R**  
**K760**

<b>Pos.</b>	<b>Part No.</b>	<b>Description</b>	<b>Quantity</b>	<b>Notes</b>	<b>New Part</b>
1	574 36 41-05	SHORTBLOCK	1		

S

K760

1

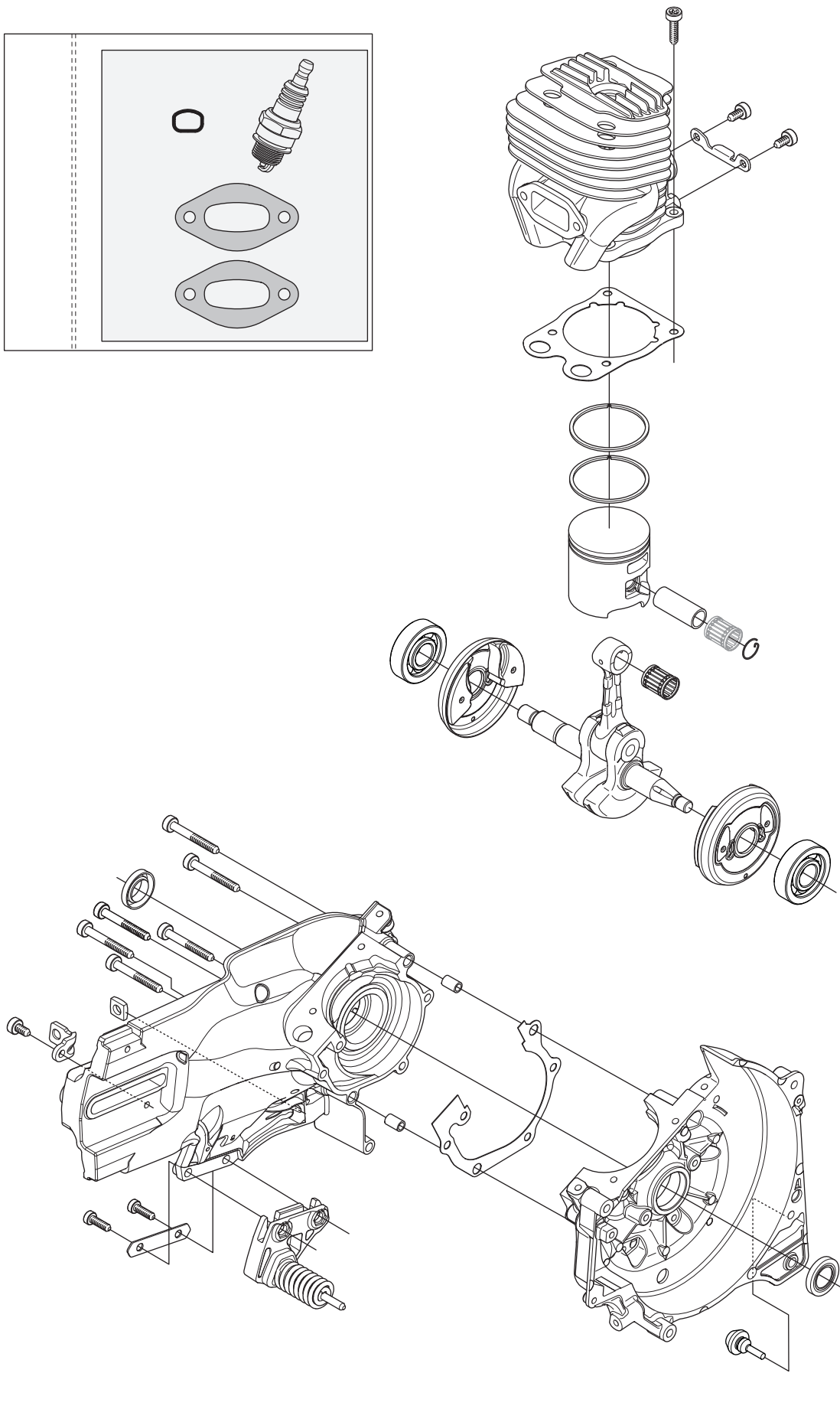
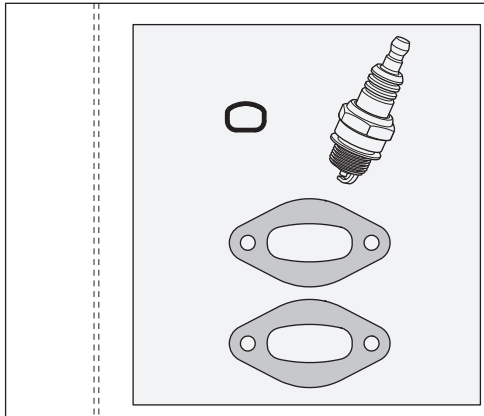

**Page S**  
**K760**

<b>Pos.</b>	<b>Part No.</b>	<b>Description</b>	<b>Quantity</b>	<b>Notes</b>	<b>New Part</b>
1	574 36 41-02	LONGBLOCK	1		