

GAS ENGINE INDEX

Crankcase.....	4
Crankshaft and Piston	5
Intake and Exhaust	6
Governor, Operation	7
Cooling, Starting	7
Fuel and Lubricant	8
Electric Device.....	9

IMPORTANT! – To assure product **SAFETY** and **RELIABILITY**, repairs should be performed by **MAKITA** Service Centers or other qualified service organizations. Always use **MAKITA** replacement parts.

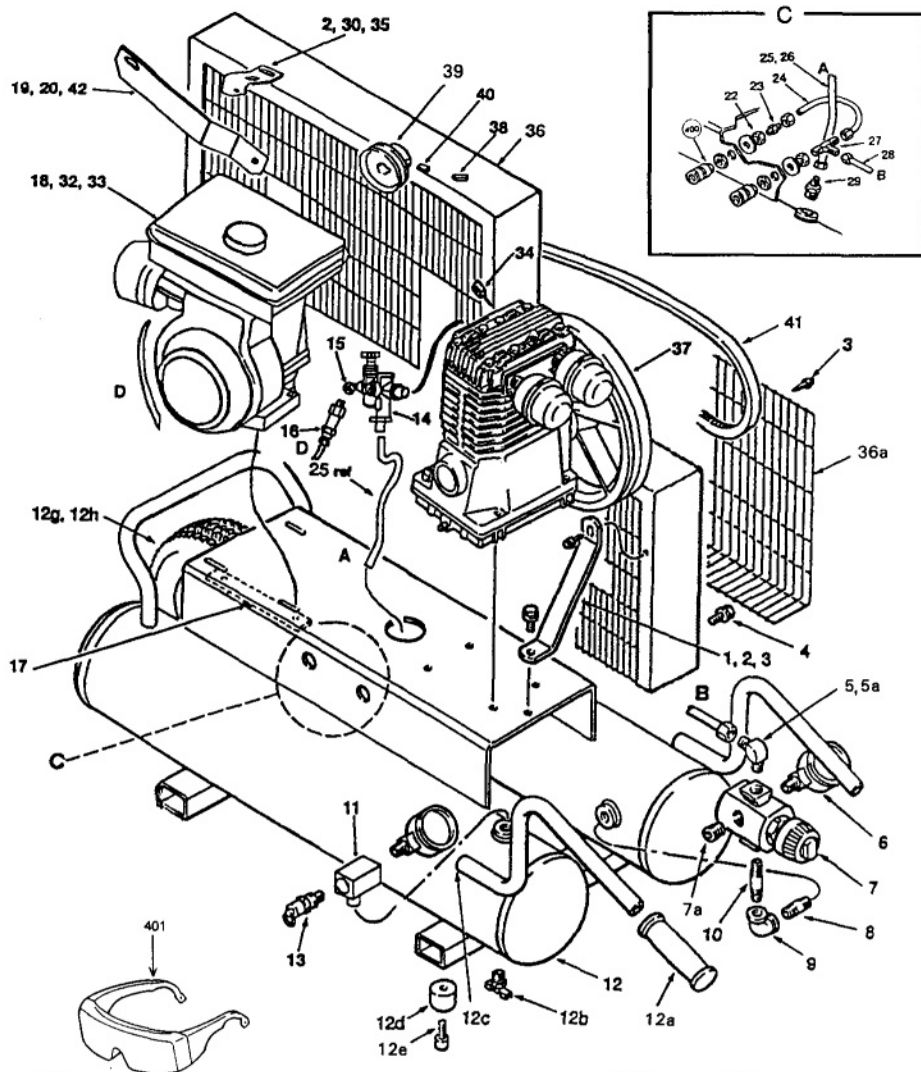
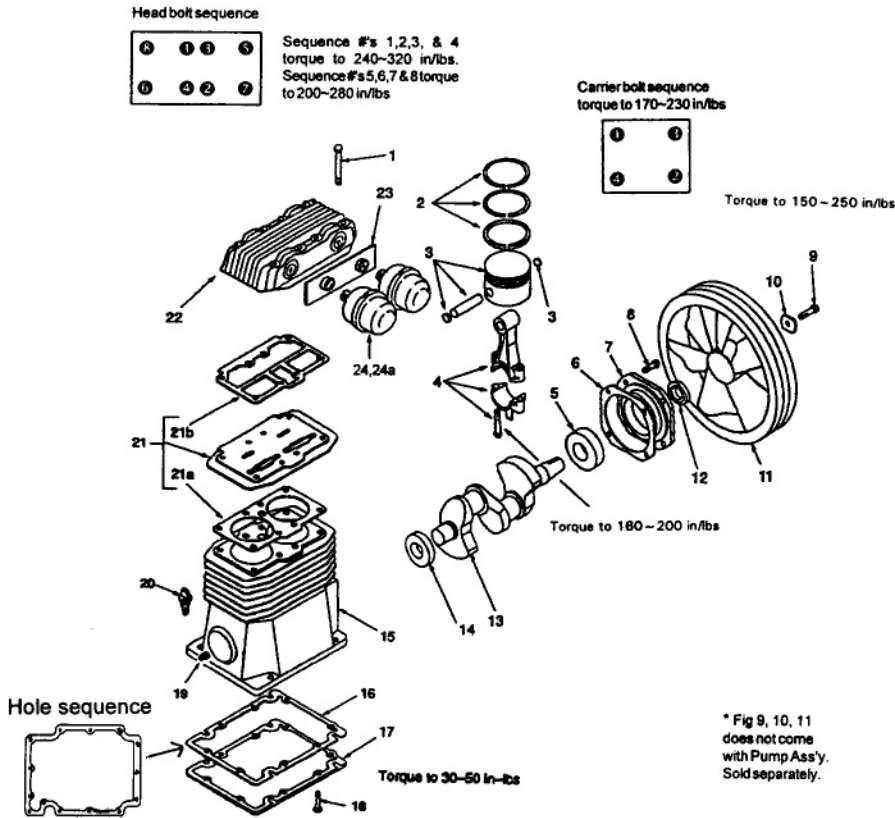

Fig.	Part No.	Qty. Used	Description	Fig.	Part No.	Qty. Used	Description
1	114000-6	1	BRACKET	22	036002-9	2	COUPLER
2	059028-4	2	SCREW, 5/16-18 x .50"lg, blk	23	068001-7	1	CONNECTOR
3	061010-5	9	SCREW, #10 x .50" lg	24	145028-0	1	TUBE, Regulator/Outlet (Incl. 2 ea. 058000-7)
4	059028-6	3	SCREW, 1/4-20 X .50" lg	25	145028-8	1	TRANSFER TUBE (Incl. 2ea. 058001-6)
5	064000-5	1	ELBOW (Incl. Fig. 5a)	26	058001-6	2	NUT, 1/2" O.D. TUBE
5a	058000-7	1	NUT	27	069001-9	1	TEE, 1/4 NPT x 3/8" O.D. Tube
6	032002-5	2	GAUGE	28	145028-1	1	TUBE, Regulator/Outlet B-B (Incl. 2ea. 058000-7)
7	019011-5	1	REGULATOR (Incl. Fig. 7a)	29	068000-9	1	CONNECTOR, male
7a	062003-5	1	PLUG, PIPE 1/4"	30	114034-8	1	BRACKET, belt guard
8	065007-5	1	NIPPLE, 3/8" x 1.50"	32	025004-0	1	GAS ENGINE (see pages 4 ~ 9 for details)
9	064003-6	1	ELBOW	33	060000-5	4	FLAT WASHER, 5/16"
10	065005-7	1	NIPPLE, 3/8 NPT x 2.0"	34	062000-1	1	PLUG, 1/8 NPT
11	069005-3	1	TEE 1/4" NPT	35	059019-5	1	SCREW, M6 x 14mm
12	150006-2	1	TANK ASS'Y, 8 gallon (Incl. Fig. 12a ~ 12h)	36	S142010-1	1	BELT GUARD ASS'Y (Incl. Fig. 36a)
12a	093002-7	2	HANDLEGRIP	36a	115006-5	1	BACK BELT GUARD
12b	072000-1	2	PETCOOK	37	040019-9	1	PUMP (see page.3 for details)
12c	077010-5	2	PLUG, SNAP 1"	38	146001-6	1	KEY
12d	094000-9	4	PAD	39	006013-4	1	PULLEY
12e	061003-6	4	SCREW, #14 x 1.0"lg	40	061000-2	1	SET SCREW
12g	110002-2	1	AXLE, 5/8" X 4.63" lg	41	007001-2	1	V-BELT
12h	095002-3	1	10" WHEEL	42	060008-3	1	LOCKWASHER
13	136000-5	1	PRESSURE RELIEF VALVE				
14	070005-1	1	UNLOADER				
15	064005-4	1	ELBOW, 1/8" x 90 deg.				
16	026028-4	1	THROTTLE CABLE				
17	114001-7	2	ENGINE BRACKET				
18	059001-1	4	SCREW, 5/16 x 1-1/4" lg				
19	059014-9	2	SCREW, 5/16 x 1/2" lg				
20	114033-2	1	STABILIZER BAR				
				ACCESSORIES			
				400	036003-1	2	COUPLER
				401	1922-A	1	PROTECTIVE EYEWEAR

040019-9 PUMP ASSEMBLY



054011-2
(Fig. 2 on page 3)

IMPORTANT: Rings must be assembled with colored stripes in the position shown below and in the following numerical sequence.

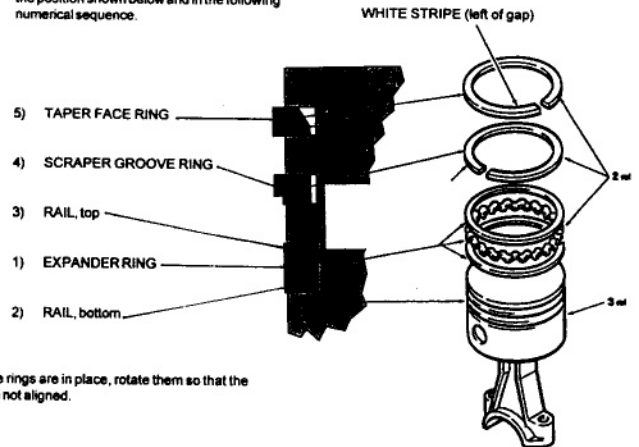

NOTE: Once the rings are in place, rotate them so that the gaps are not aligned.

Fig.	Part No.	Qty. Used	Description	Fig.	Part No.	Qty. Used	Description
1	059014-4	8	SCREW, 5/16-18 x 2.50" lg	15	S049004-4	1	CRANKCASE
2	054011-2	1	RINGSET	16	046026-3	1	GASKET
3	048006-5	1	PISTON ASS'Y	17	077014-8	1	BASE
4	047007-0	2	ROD	18	061011-3	8	SCREW, 1/4-20 x 1.25" lg
5	051004-3	1	BEARING	19	061011-2	1	PLUG, 1/8 NPT
6	046014-9	1	GASKET	20	056001-9	1	DIPSTICK
7	045004-3	1	CARRIER	21	043014-2	1	PLATE ASS'Y (Incl. Fig. 21a~ 21b)
8	059014-3	4	SCREW, 5/16-18 x .87" lg	21 a	046015-2	1	GASKET
9	059000-2	1	SCREW, 5/16-18 x 1.0" lg	21 b	046015-1	1	GASKET
10	060005-3	1	WASHER	22	042006-8	1	HEAD
11	044003-9	1	FLYWHEEL, 12" A Width	23	019009-6	1	PLATE
12	046016-1	1	SEAL	24	019016-5	2	FILTER, canister (Incl. Fig. 24a)
13	053004-3	1	CRANKSHAFT	24 a	019016-6	2	ELEMENT
14	051008-1	1	BEARING				

025004-0 GAS ENGINE

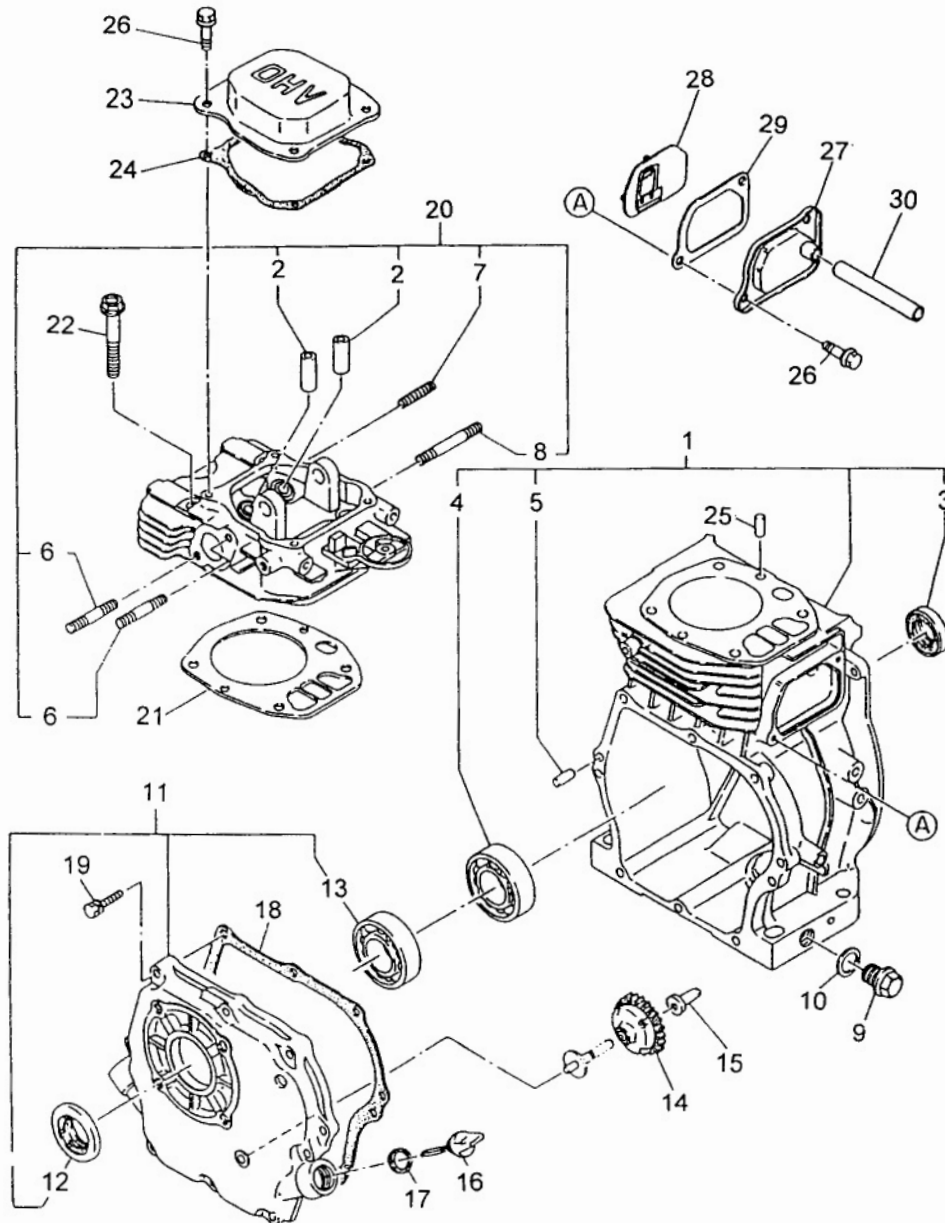

Fig.	Part No.	Qty Used	Description	Fig.	Part No.	Qty Used	Description
1	253-10201-01	1	CRANKCASE cp.	17	021-31600-20	1	GASKET
2	237-14202-03	2	VALVE GUIDE	18	253-16002-03	1	GASKET, bearing cover
3	044-02500-10	1	OIL SEAL 25x38x7	19	013-00600-40	8	BOLT & WASHER
4	060-02500-10	1	BALL BEARING	20	253-13011-01	1	CYLINDERHEAD (from S/N 1089739)
5	031-00600-20	2	DOWELPIN	20	253-13001-01	1	CYLINDERHEAD (to S/N 1089738)
6	001-32084-51	2	STUD	21	253-15001-23	1	CYL. HEAD GASKET
7	010-50601-31	1	STUD	22	011-00801-00	4	FLANGE BOLT
8	001-39066-00	1	STUD	23	253-15501-03	1	ROCKER COVER
9	040-11400-30	1	PLUG	24	253-16005-03	1	GASKET, rocker cover
10	021-11400-20	1	GASKET	25	031-00600-20	2	DOWELPIN
11	253-11014-01	1	MAIN BEARING COVER (from S/N 1089739)	26	011-00600-20	6	FLANGE BOLT
11	253-11004-01	1	MAIN BEARING COVER (to S/N 1089738)	27	253-14301-11	1	BREATHER COVER
12	044-02501-60	1	OIL SEAL 25x41.24x7	28	253-14401-01	1	BREATHER PLATE
13	060-02500-10	1	BALL BEARING	29	253-16006-33	1	GASKET, breather cover
14	227-45003-01	1	GOVERNOR GEAR	30	085-10800-00	1	RUBBER PIPE(8x11x80mm)
15	205-41901-03	1	GOVERNOR SLEEVE	•	253-99001-07	1	GASKET SET
16	227-63601-03	1	OIL GUAGE				

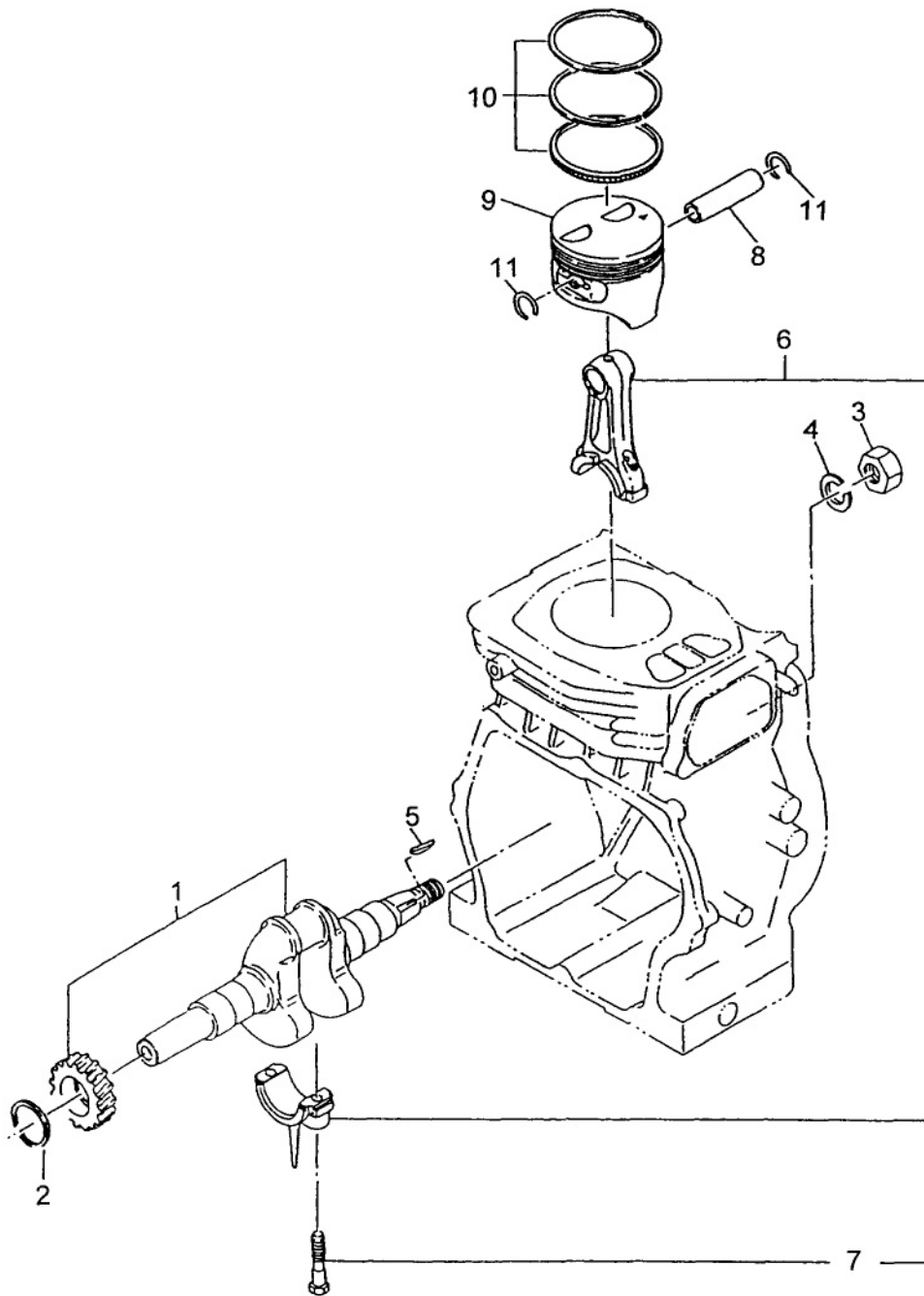

Fig.	Part No.	Qty. Used	Description	Fig.	Part No.	Qty. Used	Description
1	253-20901-01	1	CRANKSHAFT cp.	8	238-23301-03	1	PISTONPIN
2	023-02501-10	1	SPACER T=0.6mm	9	253-23401-03	1	PISTON (STD)
	023-02501-20	1	SPACER T=0.8mm		253-23402-03	1	PISTON (Oversize 0.25mm)
	023-02501-30	1	SPACER T=1.0mm		253-23403-03	1	PISTON (Oversize 0.50mm)
3	002-18140-00	1	NUT	10	253-23501-17	1	PISTONRING SET (STD)
4	003-20140-00	1	SPRINGWASHER		253-23502-17	1	PISTONRING SET (Oversize 0.25mm)
5	032-30300-10	1	WOODRUFF KEY		253-23503-17	1	PISTONRING SET (Oversize 0.50mm)
6	253-22501-20	1	CONNECTINGROD	11	056-51600-10	2	CLIP
7	238-23001-03	2	CONNECTINGRODBOLT				

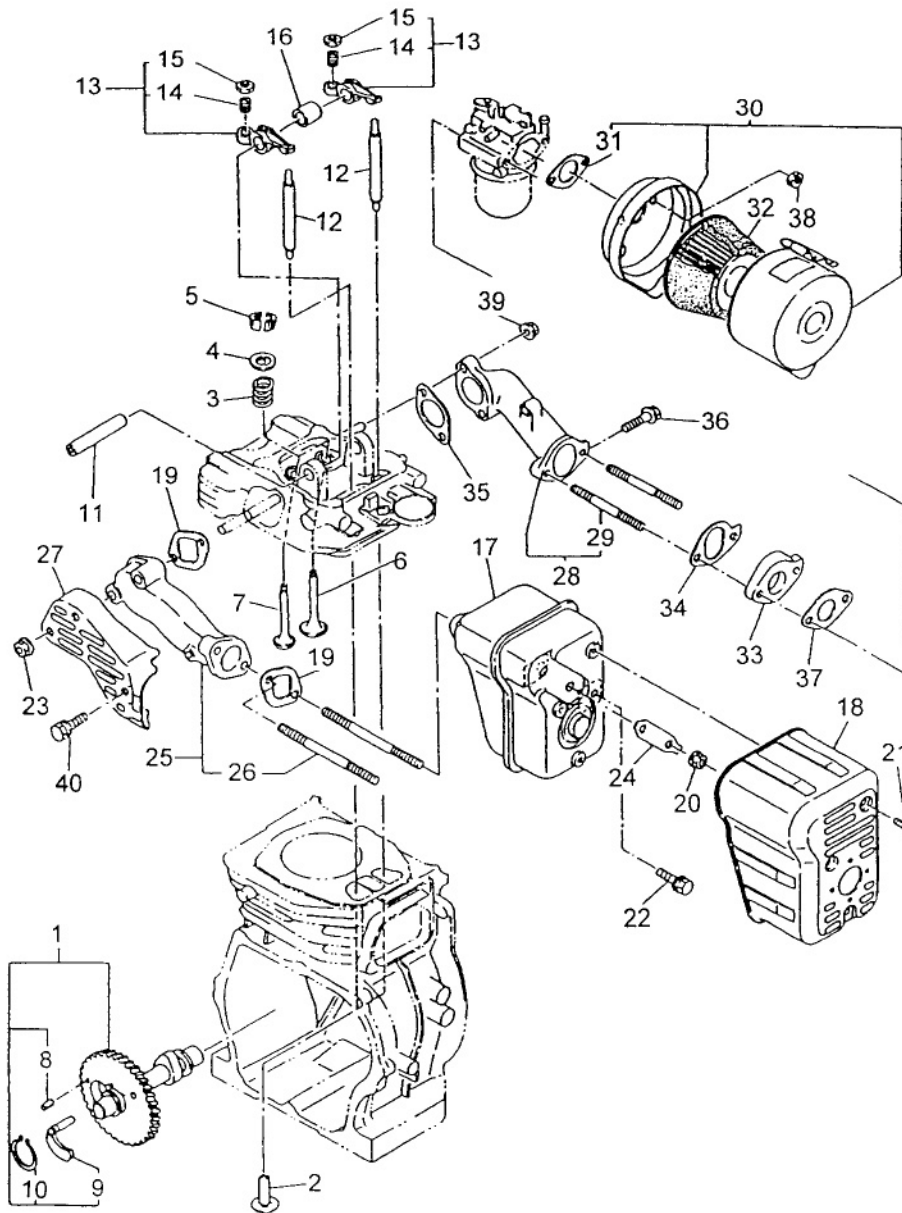

Fig.	Part No.	Qty Used	Description	Fig.	Part No.	Qty Used	Description
1	253-31701-01	1	CAMSHAFT cp.	21	015-20500-10	3	TAPPINGSREW
2	239-33301-03	2	TAPPET	22	011-00600-20	2	FLANGE BOLT
3	253-33601-03	2	VALVE SPRING	23	018-00800-10	2	FLANGE NUT
4	132-09KA0-40	2	SPRINGRETAINER	24	236-36101-03	1	LOCKWASHER
5	132-10KA0-31	2	VALVE COLLET	25	253-34001-01	1	EXHAUSTPIPE
6	253-33401-03	1	INTAKE VALVE	26	010-50804-10	2	STUD
7	253-33501-13	1	EXHAUST VALVE	27	253-34801-01	1	EXHAUSTPIPE COVER
8	005-19041-00	1	SPRINGPIN	28	253-33001-01	1	INTAKEPIPE
9	227-36401-03	1	RELEASE LEVER	29	010-50602-30	2	STUD
10	003-15220-00	1	SNAPRING (outer)	30	253-32610-00	1	AIR CLEANER
11	237-35001-03	1	ROCKER SHAFT	31	236-32630-08	1	PACKING
12	253-35301-01	2	PUSHROD	32	227-32610-07	1	ELEMENT
13	253-36101-00	2	ROCKER ARM	33	253-32901-03	1	INSULATOR
14	014-90800-21	2	ADJUSTINGSCREW	34	253-35901-03	1	GASKET 3 (insulator)
15	017-00800-90	2	NUT	35	227-35901-03	1	GASKET (insulator)
16	237-36120-13	1	SPACER	36	011-00601-30	1	FLANGE BOLT
17	253-30101-01	1	MUFFLER	37	236-35903-03	1	GASKET 2 (insulator)
18	253-34201-01	1	MUFFLER COVER	38	017-60600-20	2	SELF-LOCK NUT
19	253-35201-03	2	GASKET, muffler	39	002-38060-00	2	FLANGE NUT
20	017-00800-30	2	NUT	40	011-00600-20	2	FLANGE BOLT

Fig.	Part No.	Qty Used	Description
1	253-42301-01	1	GOVERNOR LEVER
2	227-42201-03	1	GOVERNOR SHAFT
3	253-42701-01	1	GOVERNOR ROD
4	253-42801-03	1	ROD SPRING
5	003-13060-00	2	CLIP
6	001-14063-00	1	BOLT & WASHER
7	018-60600-20	1	NUT
8	253-42501-13	1	GOVERNOR SPRING
9	227-43302-20	1	SPEED CONTROL AY.
10	227-43301-00	1	SPEED CONTROL AY.
11	227-43301-01	1	SPEED CONTROL
12	227-43302-01	1	SPEED CONTROL CP
14	227-43601-03	1	KNOB
15	227-43501-01	1	STOP PLATE
16	227-45002-03	1	SPRING WASHER
17	004-31063-00	1	SCREW
18	002-27060-00	1	NUT
19	011-00600-50	1	FLANGE BOLT
20	253-44200-01	1	WIRE BRACKET
21	004-31040-80	1	P.H. SCREW
22	002-27060-00	1	NUT

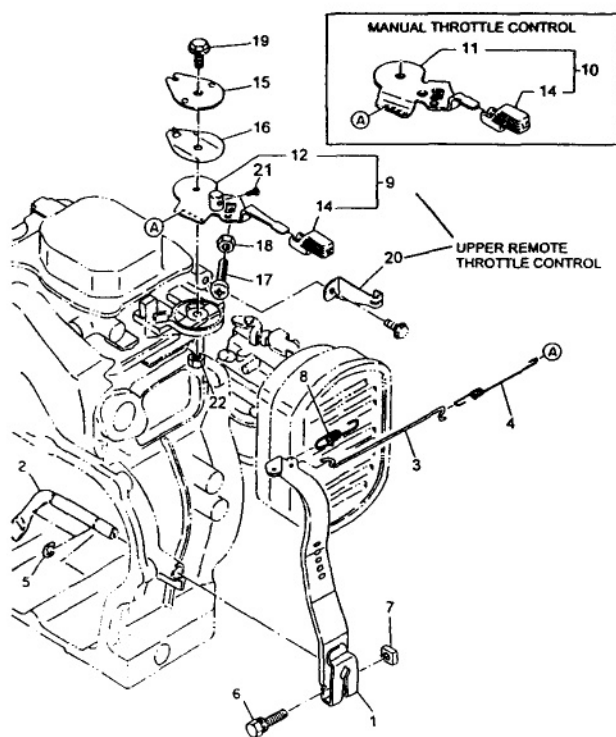
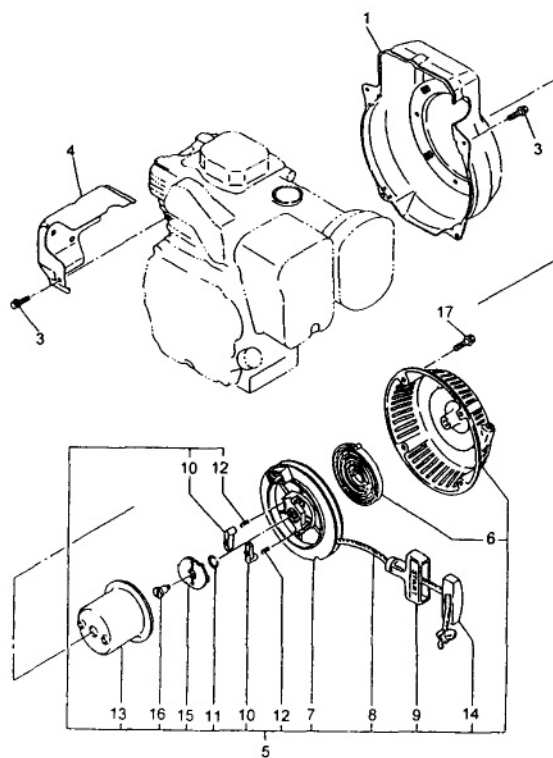

Fig.	Part No.	Qty. Used	Description
1	253-51612-01	1	BLOWER HOUSING
3	011-00600-20	5	FLANGE BOLT
4	253-52701-03	1	HEAD COVER
5	253-50201-00	1	RECOIL STARTER
6	253-50115-08	1	SPIRAL SPRING
7	252-50121-08	1	REEL
8	226-50113-08	1	STARTER ROPE
9	236-50101-08	1	STARTER KNOB
10	161-50125-08	2	RATCHET
11	227-50131-08	1	FRICTION SPRING
12	227-50135-08	2	RETURN SPRING
13	227-50149-08	1	STARTER PULLEY
14	227-50150-08	1	KNOB CAP
15	161-50150-08	1	RATCHET GUIDE
16	227-50152-08	1	SET SCREW
17	011-00600-10	4	FLANGE BOLT



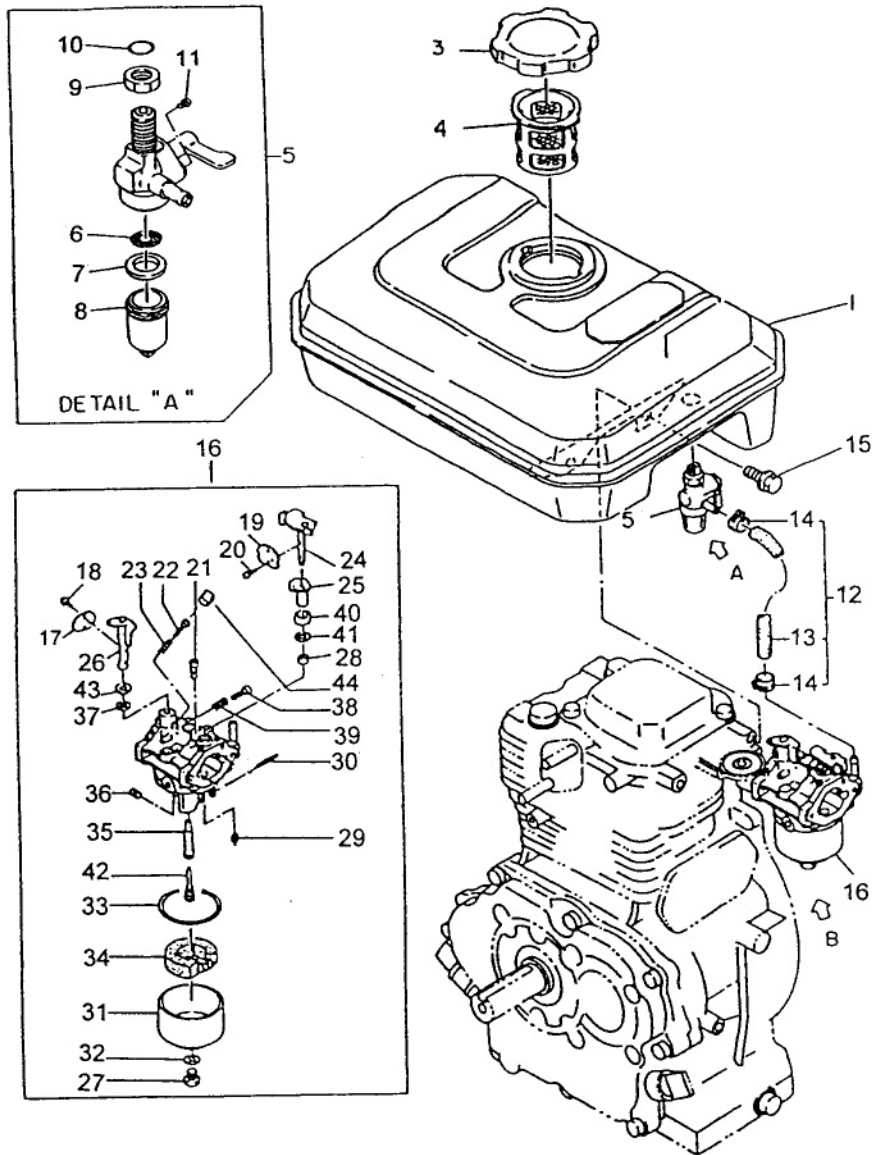

Fig.	Part No.	Qty Used	Description	Fig.	Part No.	Qty Used	Description
1	253-60108-01	1	FUEL TANK	24	236-62520-08	1	CHOKE LEVER
3	043-04300-15	1	FUEL TANK CAP	25	239-62560-08	1	RING
4	064-13600-10	1	FUEL FILTER	26	236-62600-08	1	THROTTLE SHAFT
5	064-20084-00	1	FUEL STRAINER	27	236-62451-08	1	BOLT
6	064-20042-20	1	FILTER	28	226-62550-08	1	RING
7	064-20064-10	1	PACKING	29	161-62352-08	1	NEEDLE
8	064-20078-10	1	CUP	30	236-62510-08	1	PIN
9	064-20084-10	1	NUT	31	236-62551-08	1	FLOAT CHAMBER BODY
10	064-20084-20	1	O-RING	32	236-62450-08	1	PACKING
11	064-20047-90	1	SCREW	33	236-62540-08	1	PACKING
12	253-62601-01	1	FUEL PIPE	34	236-62505-08	1	FLOAT
13	085-10600-00	1	RUBBER PIPE (6x12x70mm)	35	238-62440-08	1	MAIN NOZZLE
14	056-11100-20	2	HOSE CLAMP	36	253-62401-08	1	MAIN JET
15	011-00600-30	4	FLANGE BOLT	37	106-62392-08	1	SEAL
16	253-62404-00	1	CARBURETOR	38	246-62435-08	1	ADJUSTING SCREW
17	220-62536-08	1	THROTTLE VALVE	39	236-62445-08	1	SPRING
18	237-62451-08	2	SCREW	40	247-62550-08	1	CAP (choke)
19	236-62528-08	1	CHOKE VALVE	41	236-62680-08	1	SEAL
20	237-62451-08	2	SCREW	42	235-62425-08	1	GUIDE HOLDER
21	253-62420-08	1	PILOT JET	43	236-62631-08	1	RING
22	246-62436-08	1	PILOT SCREW	44	246-62551-08	1	CAP
23	209-62445-08	1	SPRING				

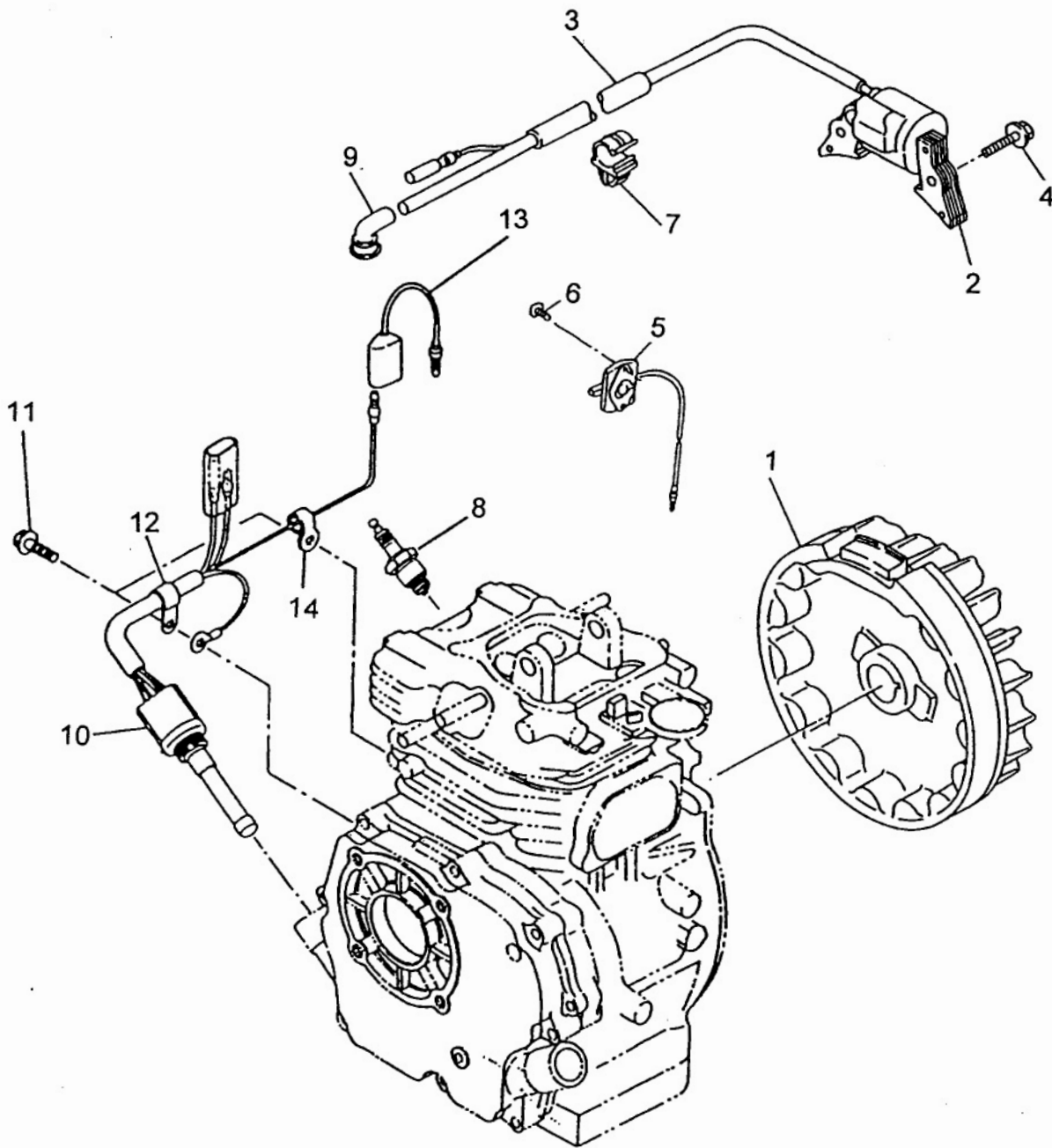

Fig.	Part No.	Qty Used	Description	Fig.	Part No.	Qty Used	Description
1	253-79330-01	1	FLYWHEEL	8	065-01400-31	1	SPARK PLUG (B6HS)
2	253-79430-41	1	IGNITION COIL	9	065-50000-51	1	SPARK PLUG CAP
3	253-71240-08	1	VINYL TUB	10	KS3-11022-11	1	OIL SENSOR
4	001-14062-50	2	BOLT & WASHER	11	001-10081-60	2	BOLT & WASHER
5	066-00003-60	1	STOP SWITCH	12	214-79003-01	1	CLAMP
6	015-00400-90	2	TAPPING SCREW	13	214-73122-01	1	WIRE 22
7	056-61200-50	1	CLAMP	14	207-75001-01	1	CLAMP