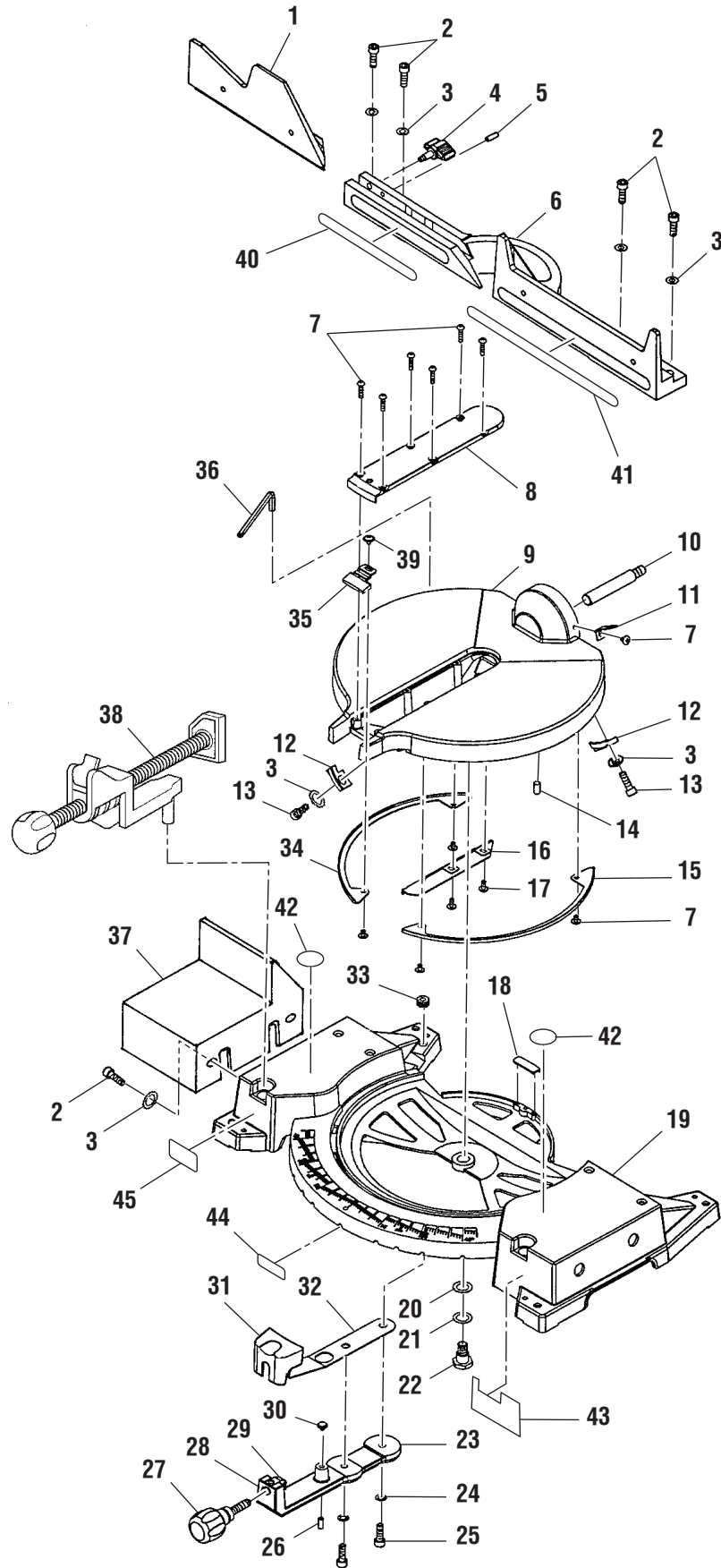

FIGURE A



## RIDGID 12 in. COMPOUND MITER SAW – MODEL NUMBER MS1250LZ1

The model number will be found on a plate attached to the motor housing. Always mention the model number in all correspondence regarding your **MITER SAW** or when ordering repair parts.

### PARTS LIST FOR FIGURE A

Key No.	Part Number	Description	Qty.
1	828102	SLIDING FENCE.....	1
2	141594-17	SCREW (5/16-18 X 1 in. SOC CAP).....	1
3	821063-6	WASHER.....	8
4	827439	FENCE KNOB.....	1
5	820244-6	SCREW M6 X 1.0 X 18 mm PAN HD).....	1
6	828103	STATIONARY FENCE.....	1
7	816755-10	SCREW (M5 X 0.8-8 mm PAN CROSS).....	6
8	826886	THROAT PLATE.....	1
9	828104	TABLE.....	1
10	827434	BEVEL PIVOT SHAFT.....	1
11	827438	BEVEL INDICATOR.....	1
12	826882	BEVEL INDEX STOP.....	2
13	9421621	SCREW (5/16-18 X 5/8 in. SOC).....	2
14	827449	SCREW (M8 X 1.25-16 mm SOC SET LK).....	1
15	823331	SHOE (LEFT).....	1
16	827879	GUARD PLATE.....	1
17	827886	SCREW (M5-10 mm SEMS).....	1
18	823361	REAR BASE SHOE.....	1
19	828105	BASE.....	1
20	828116	SPRING WASHER.....	1
21	60047	WASHER.....	1
22	823355	TABLE PIVOT BOLT.....	1
23	828106	MITER ARM.....	1
24	140785-6	TOOTH LOCKWASHER (5/16 in.).....	2
25	9421622	SCREW (5/16-18 X 3/4 in. SOC CAP).....	2
26	828040-1	SCREW (M6 X 1.0-16 mm SET LOCK).....	2
27	828032	MITER KNOB.....	1
28	828031	MITER PLATE CLAMP.....	1
29	827886-1	SCREW (SEMS PAN LOCK WASHER).....	1
30	823356	FRONT BASE SHOE.....	1
31	828128	MITER INDEX GRIP.....	1
32	828029	MITER INDEX SPRING.....	1
33	823335	GROMMET.....	1
34	823332	SHOE (RIGHT).....	1
35	826885	MITER INDICATOR.....	1
36	823492	HEX WRENCH (L25).....	1
37	828109	EXTENSION TABLE.....	1
38	828048	CLAMP.....	1
39	828119-1	SCREW (M5-12 mm SEMS).....	1
40	867216001	FENCE LABEL (LEFT).....	1
41	867216002	FENCE LABEL (RIGHT).....	1
42	867227001	NO HANDS WARNING LABEL.....	2
43	867216029	CROWN MOLDING LABEL (RIGHT).....	1
44	089100206001	DATA PLATE LABEL.....	1
45	867216031	CROWN MOLDING LABEL (LEFT).....	1
46	828050	HARDWARE BAG (NOT SHOWN)	

\* Standard Hardware Item – May Be Purchased Locally

FIGURE B

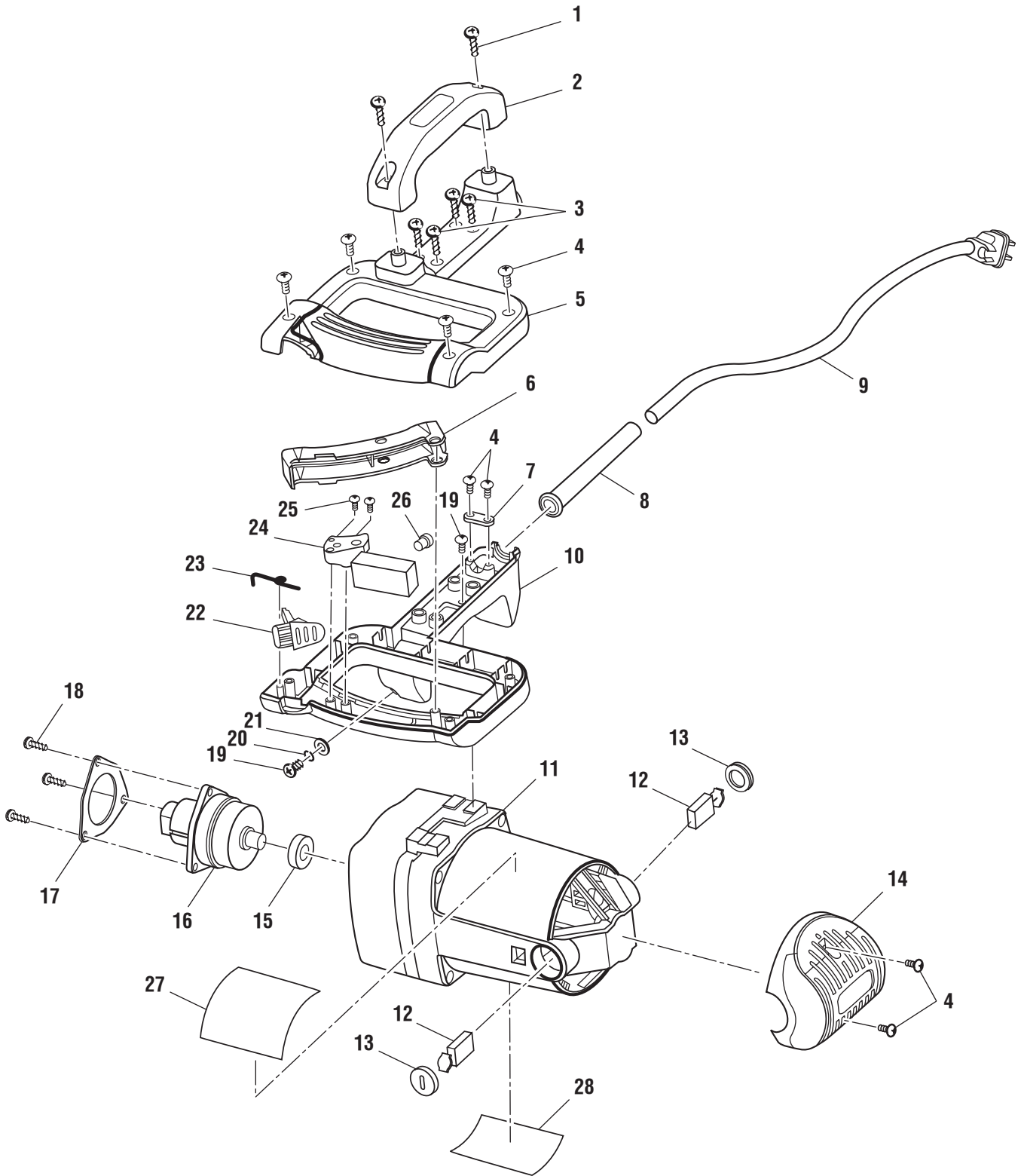

## RIDGID 12 in. COMPOUND MITER SAW – MODEL NUMBER MS1250LZ1

The model number will be found on a plate attached to the motor housing. Always mention the model number in all correspondence regarding your **MITER SAW** or when ordering repair parts.

### PARTS LIST FOR FIGURE B

Key No.	Part Number	Description	Qty.
1	828123	SCREW (M5 X 30 mm PAN HD) .....	2
2	828063	HANDLE .....	1
3	820376-5	SCREW (M4 X 0.7-22 mm PAN HD).....	4
4	828122	SCREW (M4 X 14 mm PAN HD) .....	4
5	828062	HANDLE (INCLUDES UPPER AND LOWER HANDLE) .....	1
6	828059	SWITCH ACTUATOR.....	1
7	816725	CORD CLAMP.....	1
8	821122-1	STRAIN RELIEF .....	1
9	828057	POWER CORD .....	1
10	828056	LOWER HANDLE.....	1
11	828125	MOTOR.....	1
12	816768	BRUSH .....	2
13	816770	BRUSH COVER.....	2
14	828064	REAR MOTOR COVER.....	1
15	816781	NEEDLE BEARING .....	1
16	828133-2	ARBOR ASSEMBLY .....	1
17	823271	BEARING RETAINER PLATE .....	1
18	816755-2	SCREW (M5 X 15 mm PAN HD) .....	3
19	820376-4	SCREW (M4 X 0.7-10 mm PAN HD).....	1
20	813303-4	LOCK WASHER (M4).....	1
21	821102	WASHER .....	1
22	828060	LOCK BUTTON .....	1
23	828061	TORSION SPRING .....	1
24	823493	SWITCH.....	1
25	828122-1	SCREW (M4 X 10 mm PAN HD) .....	2
26	803709-1	WIRE CONNECTOR (#12-#18).....	2
27	867216028	WARNING LABEL (ENGLISH/SPANISH) .....	1
28	867216030	WARNING LABEL (FRENCH) .....	1

\* Standard Hardware Item – May Be Purchased Locally

FIGURE D

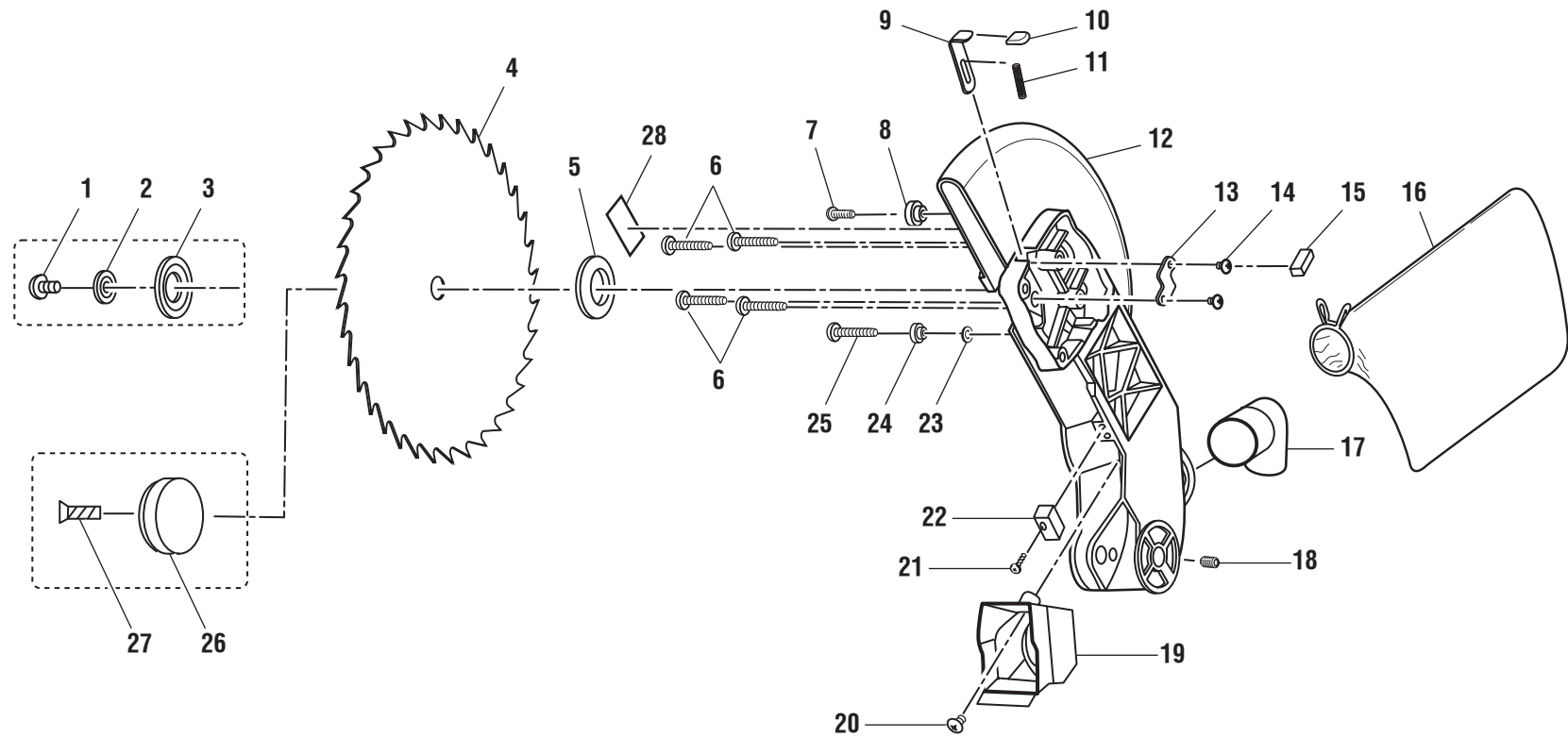

## RIDGID 12 in. COMPOUND MITER SAW – MODEL NUMBER MS1250LZ1

The model number will be found on a plate attached to the motor housing. Always mention the model number in all correspondence regarding your **MITER SAW** or when ordering repair parts.

### PARTS LIST FOR FIGURE D

Key No.	Part Number	Description	Qty.
1	830525	BLADE SCREW .....	1
2	830523	BLADE WASHER .....	1
3	830524	BLADE COLLAR (OUTER) .....	1
4	828042	BLADE .....	1
5	830526	BLADE COLLAR (INNER) .....	1
6	827886-2	SCREW (M8-35 SEMS PAN L/WSH).....	4
7	821878	SCREW (10-32 X 7/8 in. SHOULDER).....	1
8	827498	RUBBER SLEEVE .....	1
9	827512	ARBOR LOCK .....	1
10	827516	GRIP CAP .....	1
11	823402	SPRING .....	1
12	830531	UPPER ARM GUARD .....	1
13	823353	ARBOR LOCK PLATE .....	1
14	823404	SCREW (M5 X 0.8-8 mm) .....	2
15	823359	ARBOR LOCK GROMMET .....	1
16	828045	DUST BAG.....	1
17	828038	ELBOW .....	1
18	828040-1	SCREW (M6 X 1.0-16 mm SET LOCK).....	1
19	827543	SAWDUST CHUTE .....	1
20	828119	SCREW (M5 X 0.8-25 mm SEMS) .....	1
21	816755-6	SCREW (M5 X 0.8-16 mm PAN HD).....	1
22	823360	LOWER GUARD BUMPER .....	1
23	820238-2	WASHER .....	1
24	821862	BEARING GUIDE .....	1
25	821875-1	SCREW (M6 X 14 mm SHOULDER).....	1
26	830527	LASER .....	1
27	830522	LASER SCREW .....	1
28	867216027	WARNING LABEL (UPPER GUARD) .....	1

FIGURE E

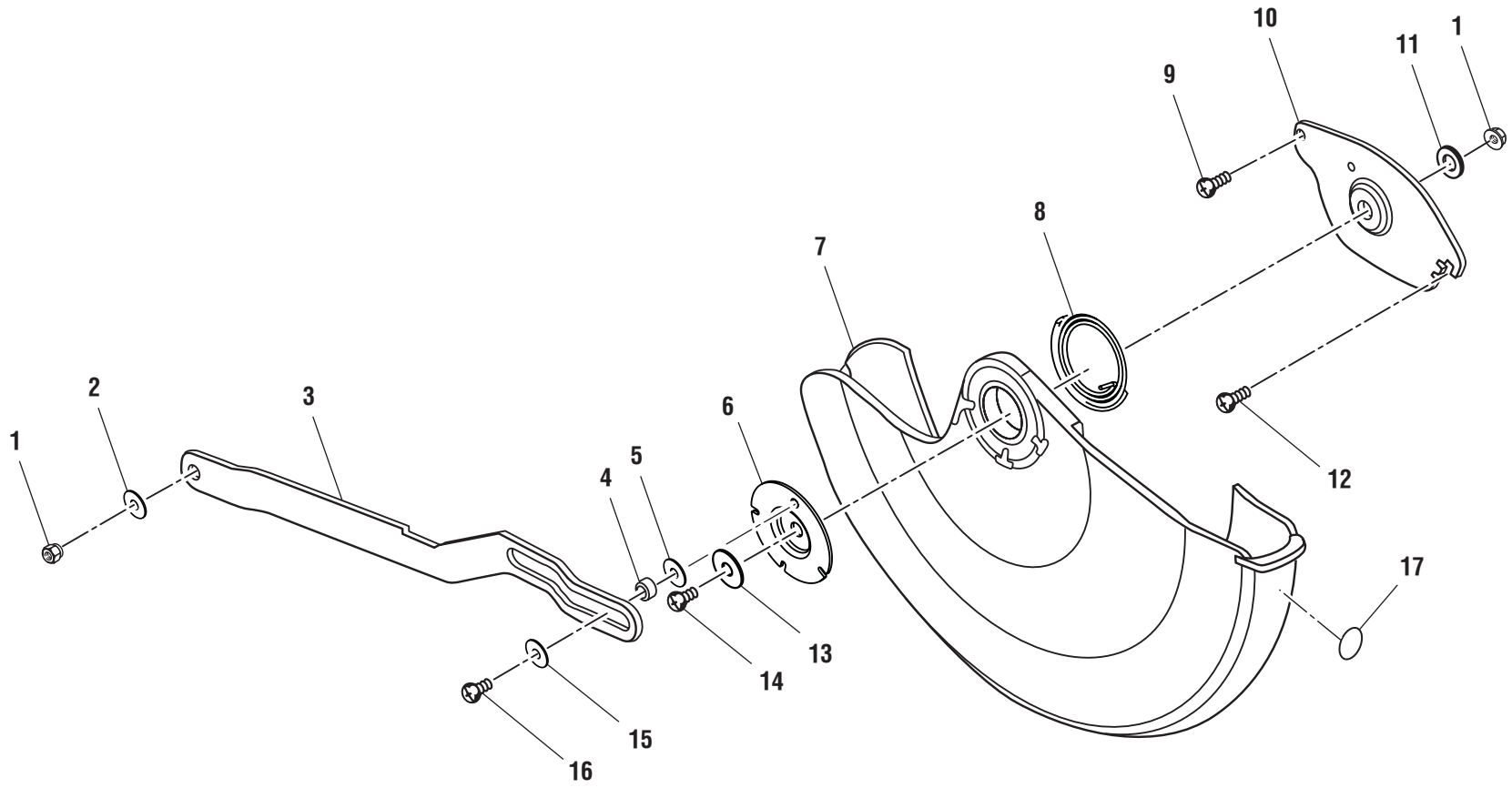

## RIDGID 12 in. COMPOUND MITER SAW – MODEL NUMBER MS1250LZ1

The model number will be found on a plate attached to the motor housing. Always mention the model number in all correspondence regarding your **MITER SAW** or when ordering repair parts.

### PARTS LIST FOR FIGURE E

Key No.	Part Number	Description	Qty.
1	817449-1	LOCK NUT (M6 X 1.0 mm) .....	2
2	820238-5	WASHER .....	1
3	823340-1	ACTUATOR LINK .....	1
4	820725-01	SPACER (7 X 10 X 4) .....	1
5	820732-2	WASHER .....	1
6	826879	GUARD RETAINER .....	1
7	830530	LOWER GUARD .....	1
8	816677	GUARD SPRING.....	1
9	821873	SCREW (10-32 X .50 SHOULDER) .....	1
10	830529	LOWER GUARD PIVOT .....	1
11	828141	WASHER .....	1
12	809372-3	SCREW (10-32 X 1/2 in. PAN HD) .....	1
13	827409	BEARING RETAINER .....	1
14	828142	SCREW (M6 X 1.0-13 mm FLAT HD).....	1
15	820732-1	WASHER .....	1
16	820724-01	SCREW (M5 X 0.8-16 mm SHOULDER).....	1
17	867227001	NO HANDS WARNING LABEL .....	1



FIGURE F

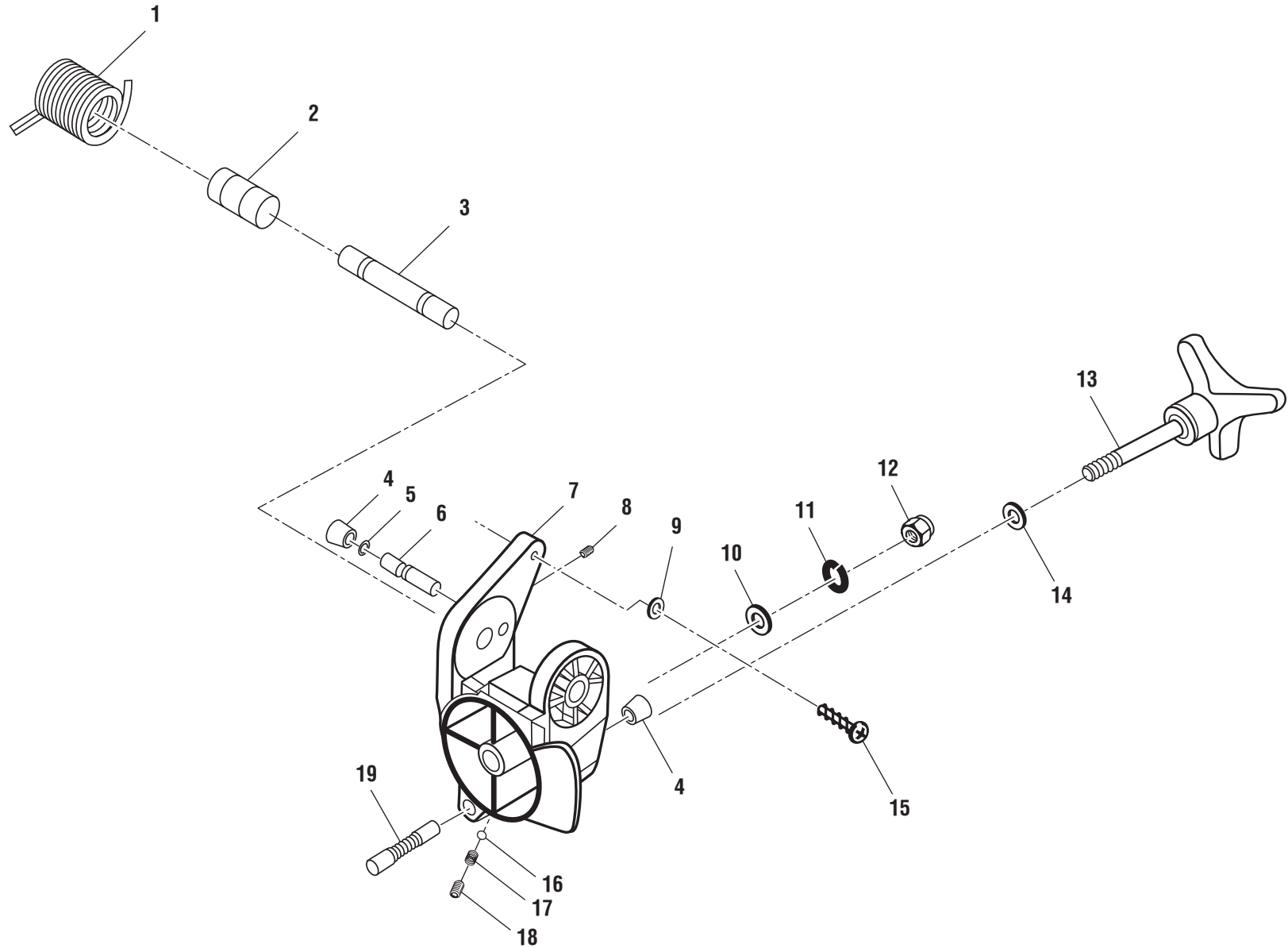

**RIDGID 12 in. COMPOUND MITER SAW – MODEL NUMBER MS1250LZ1**

The model number will be found on a plate attached to the motor housing. Always mention the model number in all correspondence regarding your **MITER SAW** or when ordering repair parts.

**PARTS LIST FOR FIGURE F**

<b>Key No.</b>	<b>Part Number</b>	<b>Description</b>	<b>Qty.</b>
1	828066	TORSION SPRING .....	1
2	823320	TORSION SPRING SPACER .....	1
3	823344	PIVOT SHAFT ARM .....	1
4	828034	RUBBER CAP .....	1
5	821421-2	O-RING .....	1
6	828035	LOCKING PIN .....	1
7	828107-1	PIVOT .....	1
8	828120	SCREW (M4 X 0.7-5 mm SET LOCK).....	1
9	821063-1	WASHER .....	1
10	828117	WASHER .....	1
11	819179	WASHER SPRING .....	1
12	818656	LOCK NUT (M12).....	1
13	827488	BEVEL KNOB .....	1
14	828170	WASHER .....	1
15	821875-4	SHOULDER SCREW (M6 X 23 mm).....	1
16	823742-2	BALL (5 mm).....	1
17	828039	SPRING .....	1
18	828040	SCREW (M6 X 1.0-10 mm SET LOCK).....	1
19	828041-1	BEVEL INDEX PIN .....	1
	983000-975	OPERATOR'S MANUAL	
	983000-975R	REPAIR SHEET (REV:01)	
	04-18-06		