

RIDGID 12 in. SLIDING COMPOUND MITER SAW – MODEL NUMBER MS1290LZ

FIGURE A

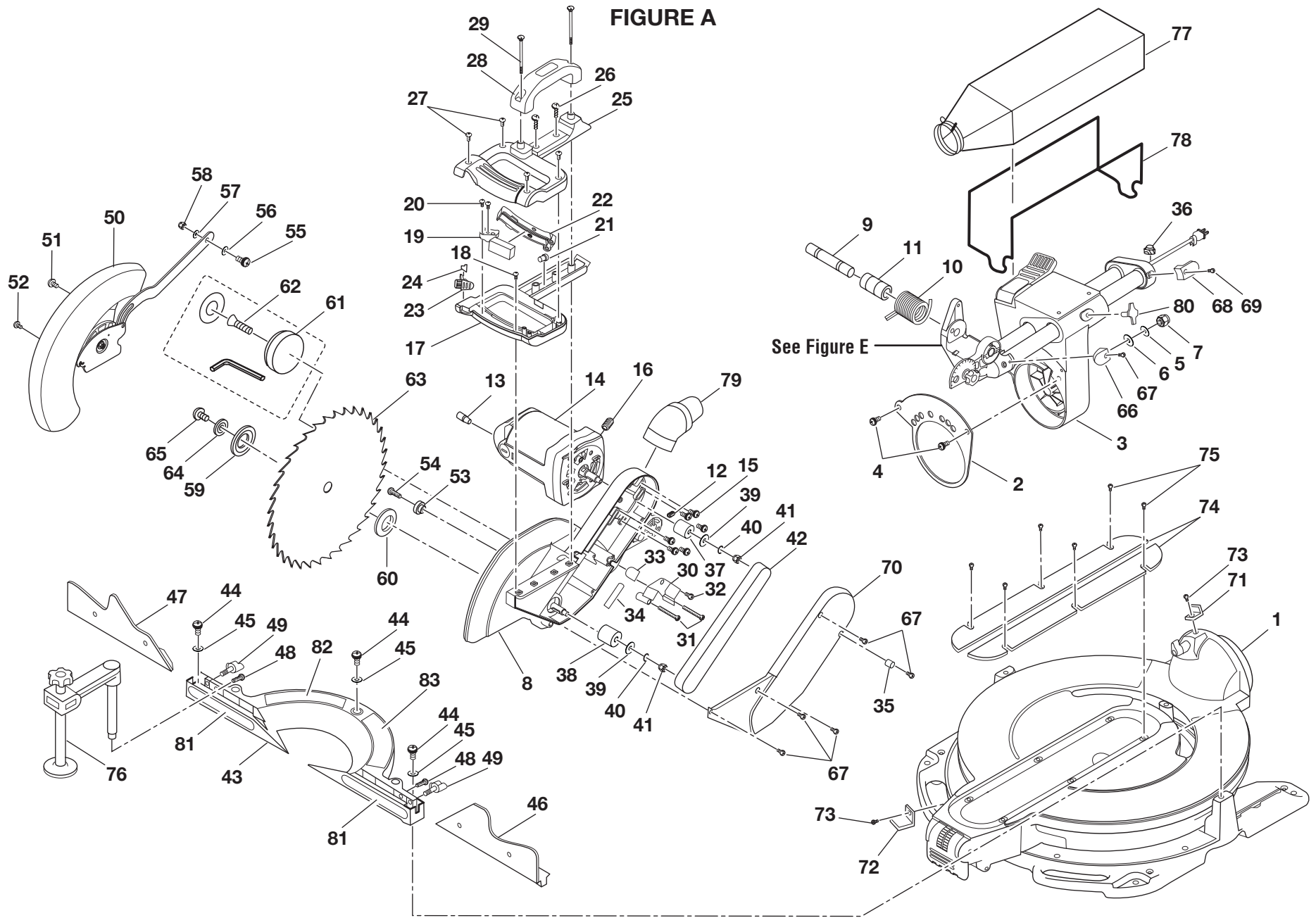

**RIDGID 12 in. SLIDING COMPOUND MITER SAW – MODEL NUMBER MS1290LZ**

The model number will be found on a plate attached to the motor housing. Always mention the model number in all correspondence regarding your **MITER SAW** or when ordering repair parts.

**PARTS LIST FOR FIGURE A**

<b>Key No.</b>	<b>Part Number</b>	<b>Description</b>	<b>Qty.</b>	<b>Key No.</b>	<b>Part Number</b>	<b>Description</b>	<b>Qty.</b>
1	830122	BASE/TABLE ASSEMBLY.....	1	24	828061	TORSION SPRING .....	1
2	830008	BEVEL SCALE .....	1	25	830039	UPPER HANDLE.....	1
3	830007	PIVOT ASSEMBLY .....	1	26	830123	SCREW (M5 X 32 mm SEMS) .....	2
4	830009	SCREW (M6 X 1.0-12 mm).....	2	27	828122	SCREW (M4 X 14 mm PAN HD) .....	4
5	828117	WASHER.....	1	28	828063	CARRY HANDLE .....	1
6	819179	SPRING WASHER .....	1	29	830123-1	SCREW (M5 X 75 mm SEMS) .....	2
7	818656	LOCK NUT (M12).....	1	30	830035	CORD COVER .....	1
8	830022	ARM GUARD ASSEMBLY .....	1	31	830124	SCREW (M5 X 35 mm PAN HD) .....	2
9	823344	ARM PIVOT SHAFT .....	1	32	816755-3	SCREW (M5 X 0.8-12 mm PAN CR).....	1
10	830131	TORSION SPRING .....	1	33	816725	CORD CLAMP .....	1
11	830111	SPRING SPACER .....	1	34	830264	CORD SLEEVE .....	1
12	828040	SCREW (M6 X 1.0-10 mm SET LOCK).....	1	35	830125	CORD CLIP.....	1
13	830023	UP STOP PIN .....	1	36	830148	STRAIN RELIEF .....	1
14	830024	MOTOR ASSEMBLY.....	1	37	830026	MOTOR PULLEY .....	1
15	830025	SCREW (M6 X 16 mm) .....	6	38	830033	PINION PULLEY .....	1
16	830164	SCREW (M8 X 25 mm SET LOCK) .....	1	39	821063	WASHER.....	2
17	830037	LOWER HANDLE.....	1	40	813303-7	LOCK WASHER (M8).....	2
18	813312	SCREW (M4 X 0.7-10 mm PAN CR).....	1	41	820236-7	HEX NUT (M8 X 1.25 mm).....	2
19	823494	SWITCH.....	1	42	830034	BELT (POLY VEE).....	1
20	828122-1	SCREW (M4 X 10 mm PAN HD) .....	2	43	080017005592	LOWER FENCE (INCLUDES LABELS) .....	1
21	803709-1	WIRE CONNECTOR (#12-#18).....	1	44	830129	SCREW (M8 X 1.25-20 mm SOC CAP).....	3
22	828059	SWITCH ACTUATOR.....	1	45	821063-6	WASHER.....	3
23	828060	LOCK BUTTON .....	1	46	830005	RIGHT SLIDING FENCE .....	1

**RIDGID 12 in. SLIDING COMPOUND MITER SAW – MODEL NUMBER MS1290LZ**

The model number will be found on a plate attached to the motor housing. Always mention the model number in all correspondence regarding your **MITER SAW** or when ordering repair parts.

**PARTS LIST FOR FIGURE A CONTINUED**

<b>Key No.</b>	<b>Part Number</b>	<b>Description</b>	<b>Qty.</b>	<b>Key No.</b>	<b>Part Number</b>	<b>Description</b>	<b>Qty.</b>
47	830006	LEFT SLIDING FENCE.....	1	67	830124-2	SCREW (M5 X 14 mm PAN HD) .....	6
48	820244-6	SCREW (M6 X 1.0-20 mm PAN HD).....	2	68	830017	REAR CORD WRAP .....	1
49	830004	FENCE LOCK KNOB .....	2	69	830124-3	SCREW (M5 X 20 mm PAN HD) .....	1
50	830040	LOWER GUARD ASM.....	1	70	830036	BELT COVER .....	1
51	821873	SCREW (10-32 X 1/2 in. SHOULDER).....	1	71	829994	BEVEL INDICATOR.....	1
52	020123008	SCREW (10-32 X 1/2 in. PAN HD) .....	1	72	829995	MITER INDICATOR .....	1
53	827498	RUBBER SLEEVE.....	1	73	830130-1	SCREW (M4 X 8 mm SEMS PN CR L+F WASH) .....	2
54	821878	SCREW (10-32 X 7/8 in. SHOULDER).....	1	74	829989	TABLE INSERT .....	2
55	089100303005	SCREW (M6 X 22 mm SHOULDER).....	1	75	816755-10	SCREW (M5 X 0.8-8 mm PAN CROSS).....	6
56	821063-1	WASHER.....	1	76	830079	CLAMP ASSEMBLY.....	1
57	820238-5	WASHER.....	1	77	830077	DUST BAG ASSEMBLY .....	1
58	817449-1	LOCK NUT (M6 X 1.0).....	1	78	830076	DUST BAG FRAME .....	1
59	089100300052	BLADE COLLAR (OUTER) .....	1	79	830078	DUST ELBOW .....	1
60	830526	BLADE COLLAR (INNER) .....	1	80	830015	SLIDE LOCK KNOB.....	1
61	880062	EXACTLINE LASER AND SCREW .....	1	81	867226000	FENCE LABEL .....	2
62	830522	LASER SCREW (M10 x 26 mm) .....	1	82	867226010	FENCE WARNING LABEL (RIGHT) .....	1
63	830000	BLADE .....	1	83	867226004	FENCE WARNING LABEL (LEFT).....	1
64	830523	BLADE WASHER .....	1		983000579	OPERATOR'S MANUAL	
65	830525	ARBOR SCREW (M10 x 20 mm) .....	1		6-22-09		
66	830016	FRONT CORD WRAP .....	1		(REV:10)		

FIGURE B

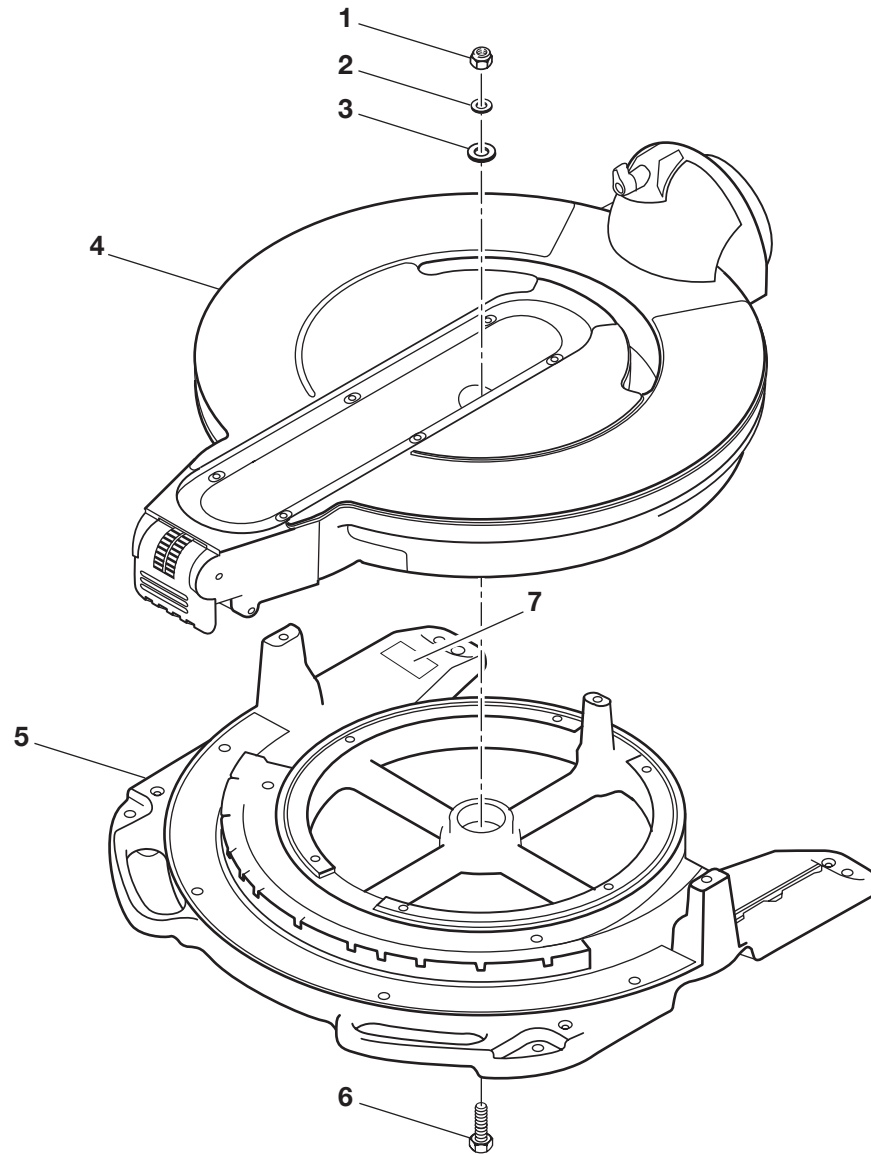

**RIDGID 12 in. SLIDING COMPOUND MITER SAW – MODEL NUMBER MS1290LZ**

The model number will be found on a plate attached to the motor housing. Always mention the model number in all correspondence regarding your **MITER SAW** or when ordering repair parts.

**PARTS LIST FOR FIGURE B**

<b>Key No.</b>	<b>Part Number</b>	<b>Description</b>	<b>Qty.</b>
1	818656	LOCK NUT (M12).....	1
2	830137	WASHER.....	1
3	830138	WASHER.....	1
4	829981	TABLE ASSEMBLY .....	1
5	830136	BASE ASSEMBLY.....	1
6	822072	SCREW (M12 X 1.75-40 mm HEX HD).....	1
7	867226015	DATA PLATE LABEL.....	1

FIGURE C

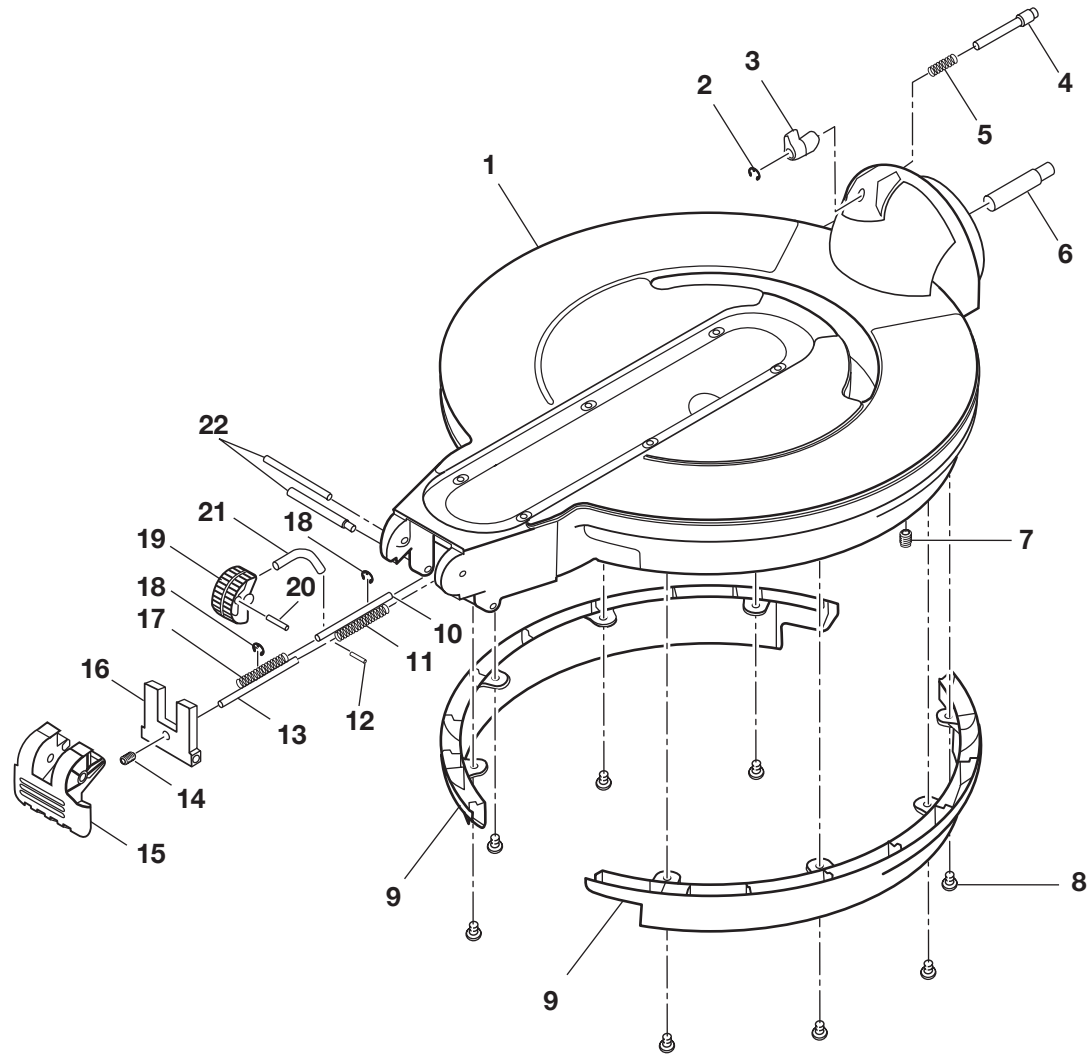

**RIDGID 12 in. SLIDING COMPOUND MITER SAW – MODEL NUMBER MS1290LZ**

The model number will be found on a plate attached to the motor housing. Always mention the model number in all correspondence regarding your **MITER SAW** or when ordering repair parts.

**PARTS LIST FOR FIGURE C**

<b>Key No.</b>	<b>Part Number</b>	<b>Description</b>	<b>Qty.</b>
1	830280	TABLE ASSEMBLY .....	1
2	829984-1	RETAINING RING .....	1
3	829992	BEVEL INDEX LEVER .....	1
4	829990	BEVEL INDEX PIN .....	1
5	829991	SPRING .....	1
6	028307009	PIVOT SHAFT .....	1
7	827449-1	SCREW (M8 X 1.25-10 mm SET LOCK).....	1
8	820244-2	SCREW (M6 X 1.0-10 mm PAN).....	8
9	829982	TABLE SKIRT.....	2
10	830044	MITER INDEX PIN.....	1
11	829983	SPRING .....	1
12	830141	ROLL PIN.....	1
13	829985	MITER LOCK PIN .....	1
14	827449	SCREW (M8 X 1.25-16 mm SOC SET LOCK) .....	1
15	829988	MITER LOCK LEVER .....	1
16	829986	MITER LOCK PLATE.....	1
17	829983	SPRING .....	1
18	829984	RETAINING RING .....	2
19	830046	MITER INDEX WHEEL .....	1
20	830140	ROLL PIN.....	1
21	830045	MITER INDEX LINK.....	1
22	829987	SCREW (M6 X 8 X 91 mm SHOULDER).....	2

FIGURE D

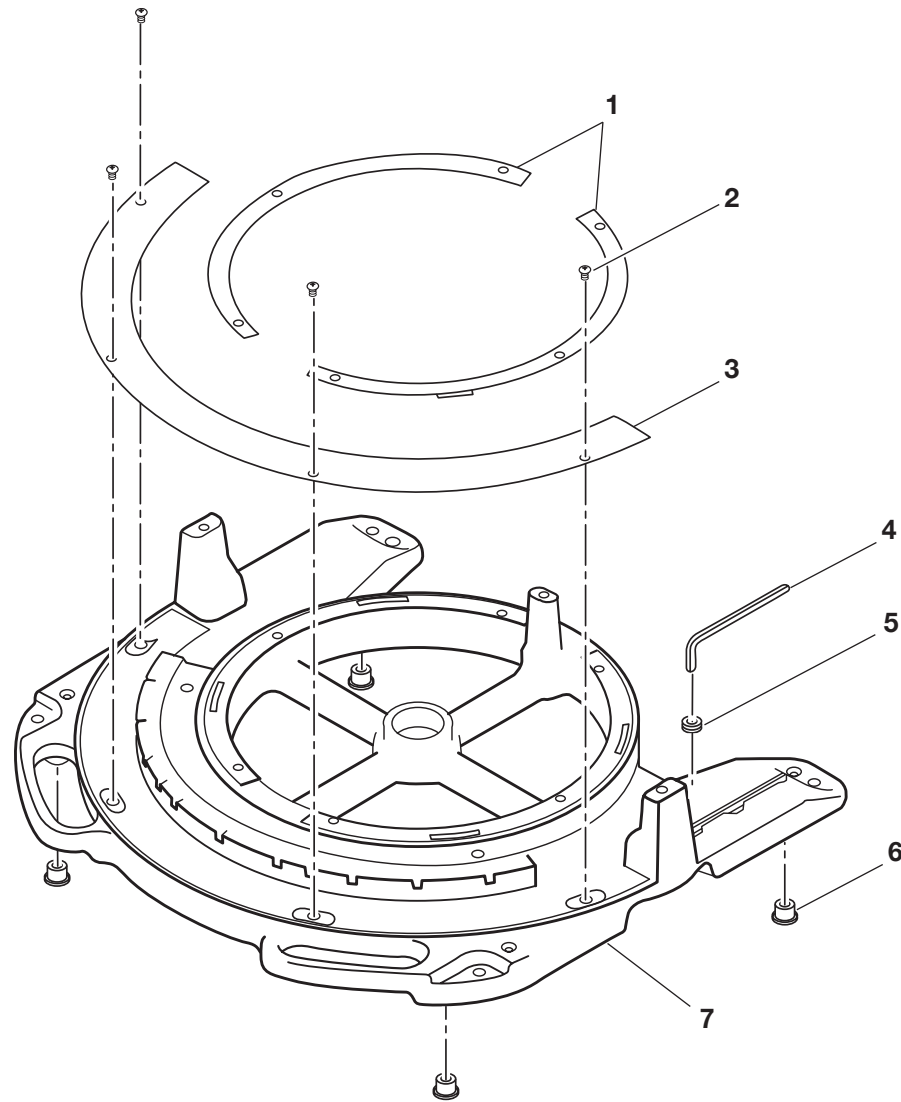



**RIDGID 12 in. SLIDING COMPOUND MITER SAW – MODEL NUMBER MS1290LZ**

The model number will be found on a plate attached to the motor housing. Always mention the model number in all correspondence regarding your **MITER SAW** or when ordering repair parts.

**PARTS LIST FOR FIGURE D**

<b>Key No.</b>	<b>Part Number</b>	<b>Description</b>	<b>Qty.</b>
1	829997	TABLE SHIM .....	2
2	830166	SCREW (M5 X 0.8-10 mm FLAT) .....	4
3	829999	MITER SCALE .....	1
4	823492	HEX KEY (1/4 in. X 120 mm).....	1
5	823335	WRENCH GROMMET .....	1
6	829998	RUBBER FOOT .....	4
7	829996	BASE .....	1

FIGURE E

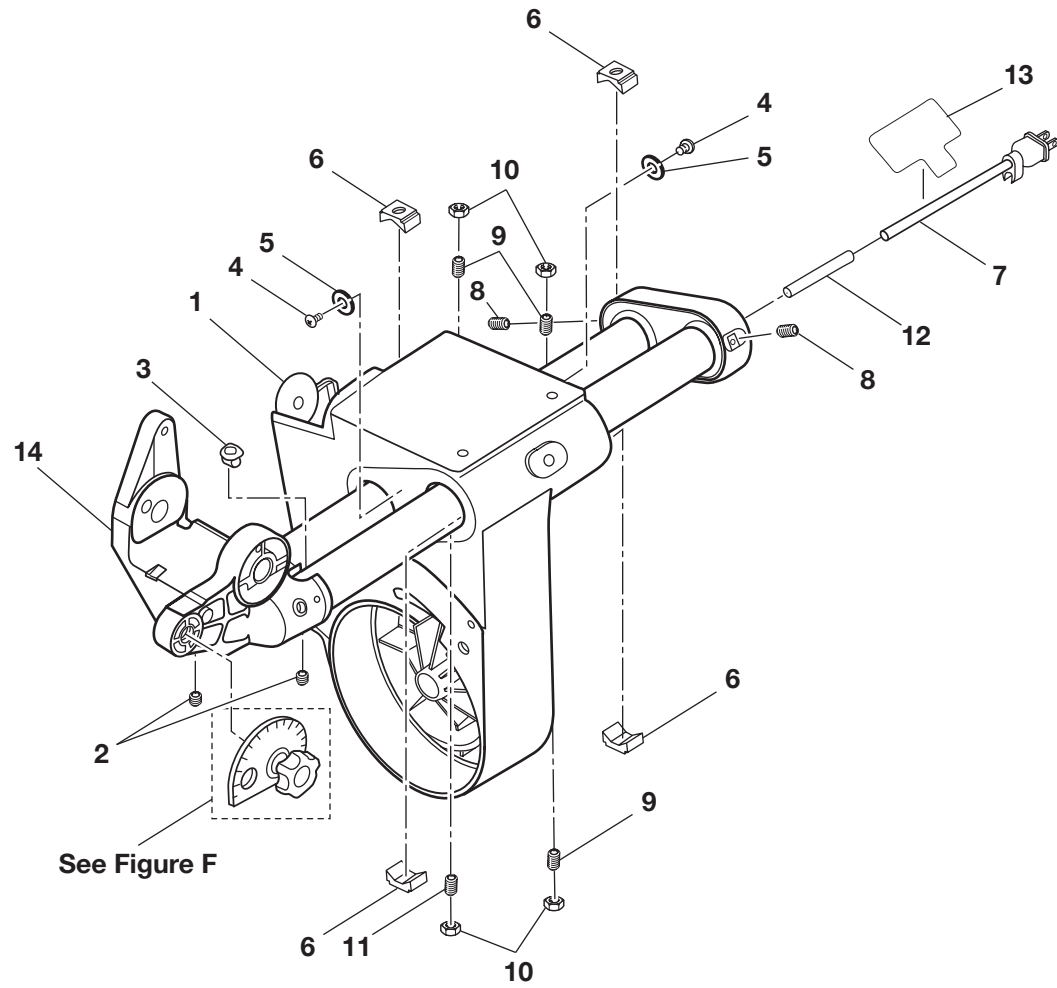

## RIDGID 12 in. SLIDING COMPOUND MITER SAW – MODEL NUMBER MS1290LZ

The model number will be found on a plate attached to the motor housing. Always mention the model number in all correspondence regarding your **MITER SAW** or when ordering repair parts.

### PARTS LIST FOR FIGURE E

Key No.	Part Number	Description	Qty.
1	830262	PIVOT ASSEMBLY ONLY .....	1
2	830146	SCREW (M8 X 1.25-6 mm SET LOCK).....	2
3	830147	CORD GUARD.....	1
4	830145	SCREW (M5 SHOULDER) .....	2
5	830053	RUBBER WASHER.....	2
6	830048	GLIDE TUBE .....	4
7	830038	CORD W/PLUG .....	1
8	830146-1	SCREW (M8 X 1.25-14 mm SET LOCK).....	2
9	830144-1	SCREW (M8 X 1.25-20 mm SET LOCK).....	3
10	824026-7	HEX NUT (M8 X 1.25 mm) .....	4
11	830144	SCREW (M8 X 1.25-25 mm SET LOCK).....	1
12	830264-1	CORD SLEEVE .....	1
13	867226014	WARNING LABEL (FR./SP.) .....	1
14	080017005591	PIVOT BRACKET .....	1

FIGURE F

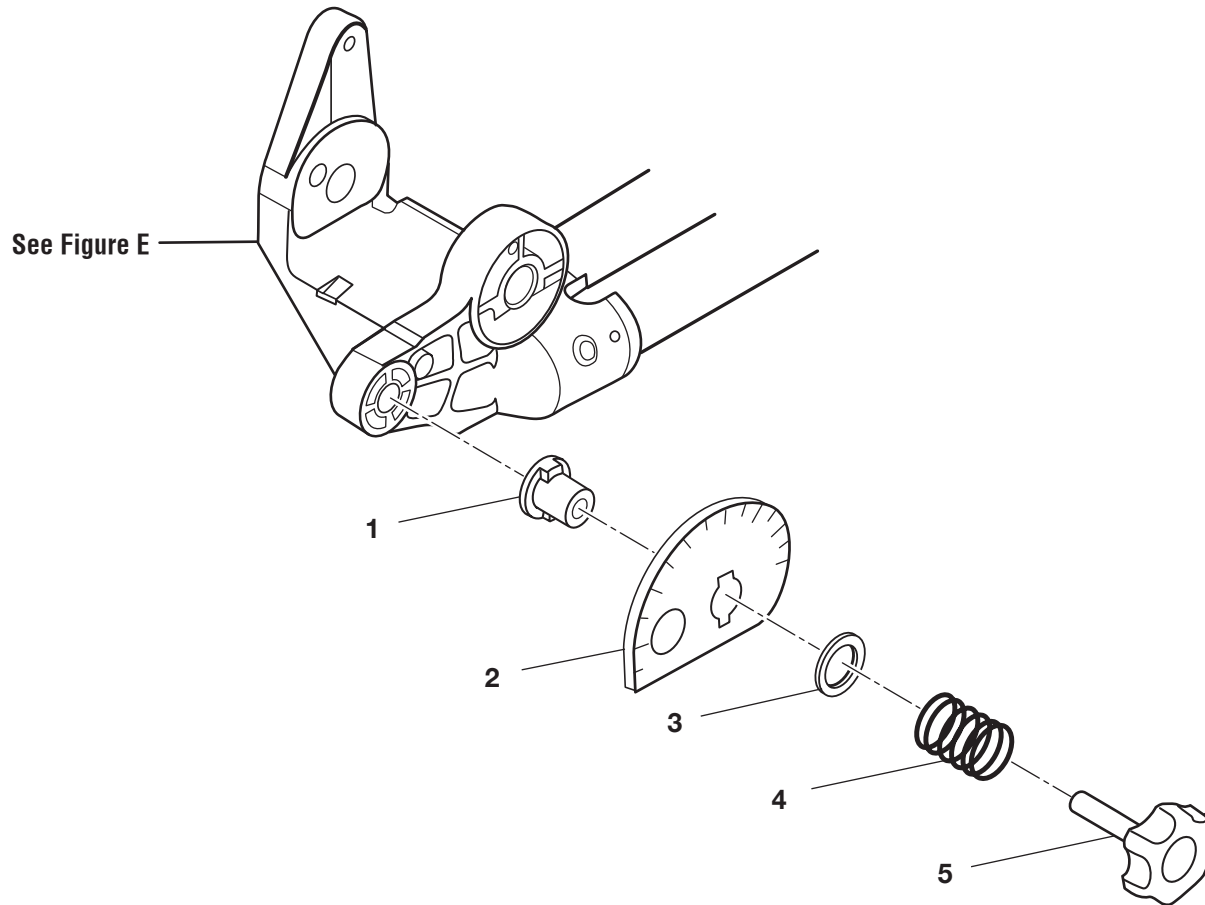

**RIDGID 12 in. SLIDING COMPOUND MITER SAW – MODEL NUMBER MS1290LZ**

The model number will be found on a plate attached to the motor housing. Always mention the model number in all correspondence regarding your **MITER SAW** or when ordering repair parts.

**PARTS LIST FOR FIGURE F**

<b>Key No.</b>	<b>Part Number</b>	<b>Description</b>	<b>Qty.</b>
1	830018	FLANGE DOWN STOP BEARING .....	1
2	830019	ECCENTRIC PLATE.....	1
3	830149	WASHER.....	1
4	830020	SPRING .....	1
5	830021	DOWN STOP KNOB.....	1

FIGURE G

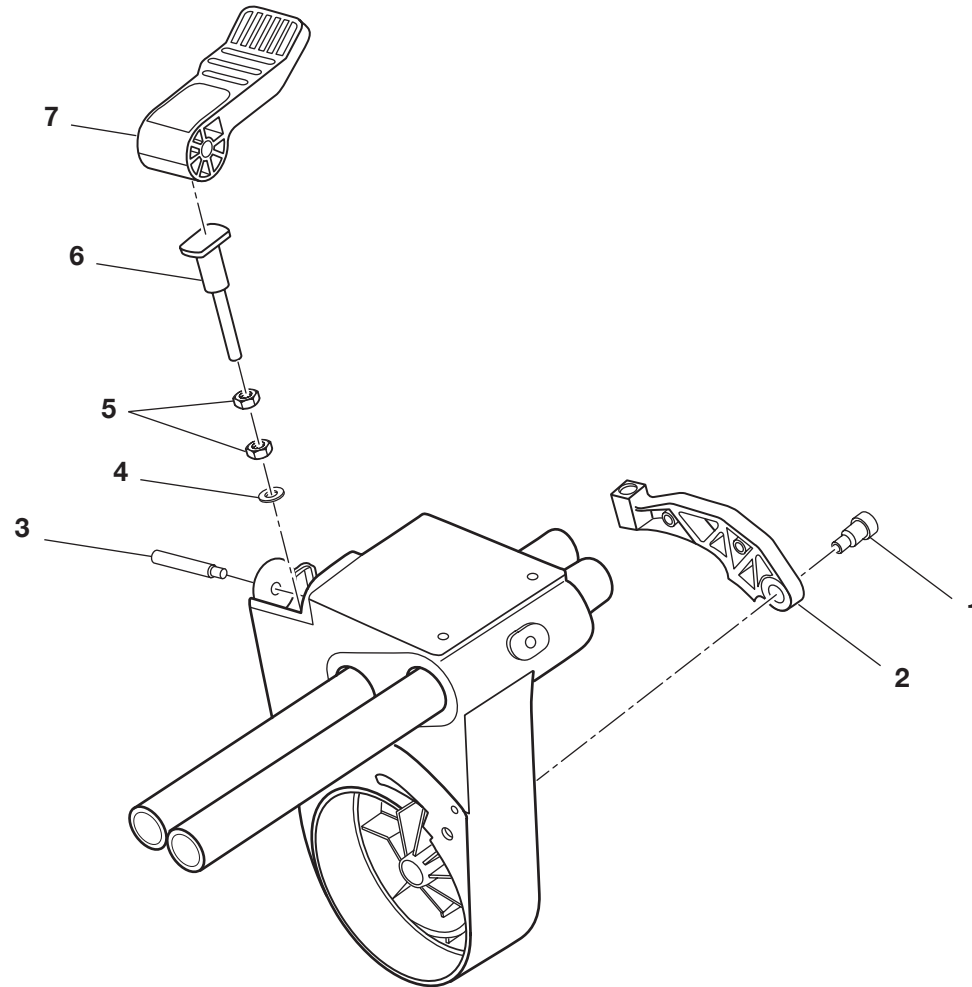

**RIDGID 12 in. SLIDING COMPOUND MITER SAW – MODEL NUMBER MS1290LZ**

The model number will be found on a plate attached to the motor housing. Always mention the model number in all correspondence regarding your **MITER SAW** or when ordering repair parts.

**PARTS LIST FOR FIGURE G**

<b>Key No.</b>	<b>Part Number</b>	<b>Description</b>	<b>Qty.</b>
1	830151	SCREW (M8 SHOULDER) .....	1
2	830010	BEVEL CLAMP .....	1
3	830011	SCREW (M6 X 1 X 58.5 mm SHOULDER).....	1
4	821063-7	WASHER.....	1
5	820236-7	HEX NUT (M8 X 1.25 mm) .....	2
6	830012	BEVEL LOCK PLUNGER.....	1
7	830013	BEVEL LOCK LEVER.....	1

FIGURE H

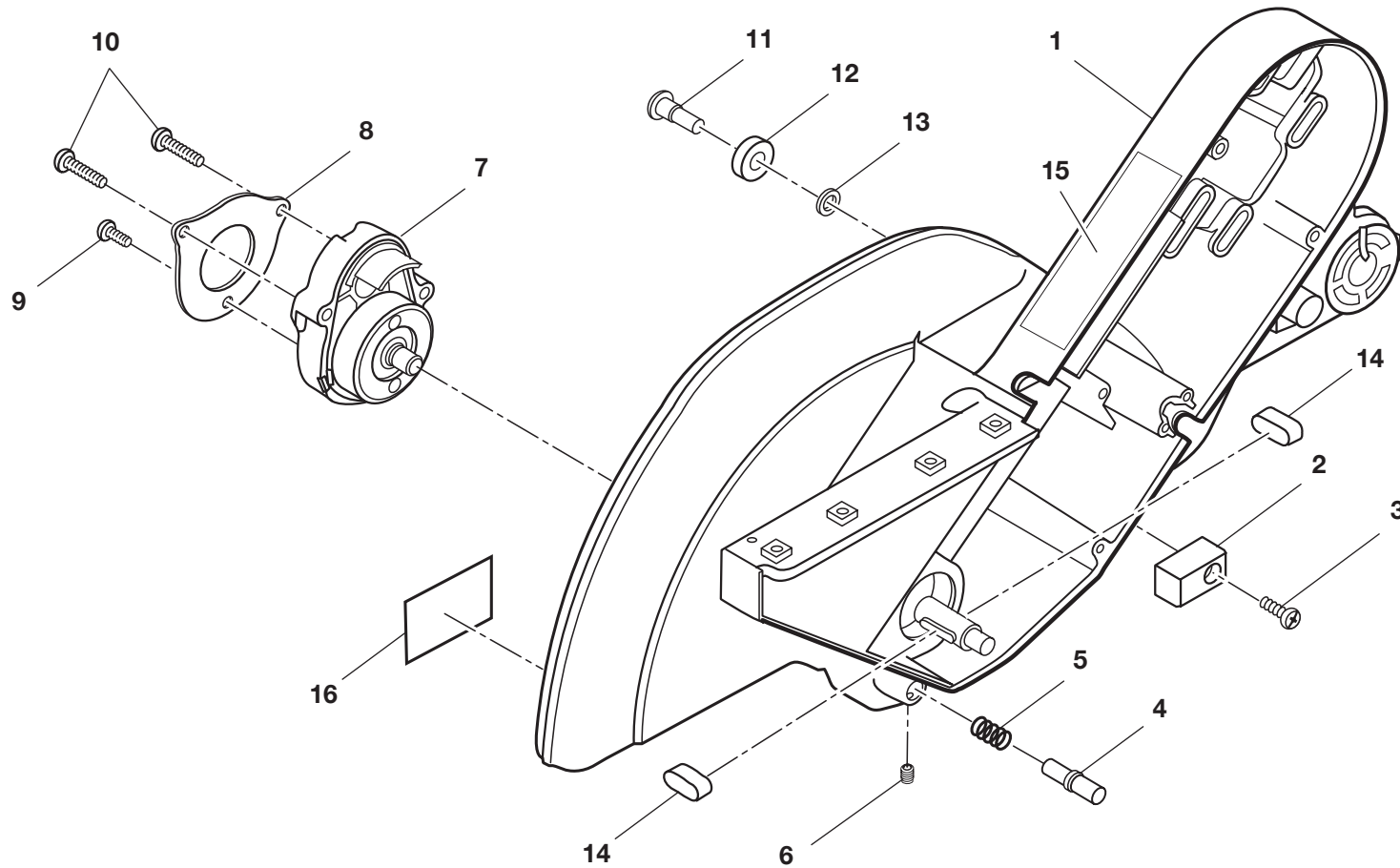



## RIDGID 12 in. SLIDING COMPOUND MITER SAW – MODEL NUMBER MS1290LZ

The model number will be found on a plate attached to the motor housing. Always mention the model number in all correspondence regarding your **MITER SAW** or when ordering repair parts.

### PARTS LIST FOR FIGURE H

Key No.	Part Number	Description	Qty.
1	830225	ARM GUARD .....	1
2	823360	LOWER GUARD BUMPER .....	1
3	816755-6	SCREW (M5 X 0.8-16 mm PAN HD).....	1
4	830029	ARBOR LOCK PIN.....	1
5	830030	SPRING .....	1
6	830155	SCREW (M4 X 5 mm SET LOCK) .....	1
7	830031-2	ARBOR ASSEMBLY.....	1
8	830032	BEARING RETAINER PLATE .....	1
9	830154-1	SCREW (M5 X 12 mm SEMS) .....	1
10	830154	SCREW (M5 X 25 mm SEMS) .....	2
11	821875-1	SCREW (M6 X 1.0-14 mm SHOULDER).....	1
12	821862	BEARING GUIDE .....	1
13	820238-2	WASHER.....	1
14	830027	KEY.....	2
15	867226003	OPERATION LABEL.....	1
16	867216027	WARNING LABEL (UPPER GUARD) .....	1

FIGURE I

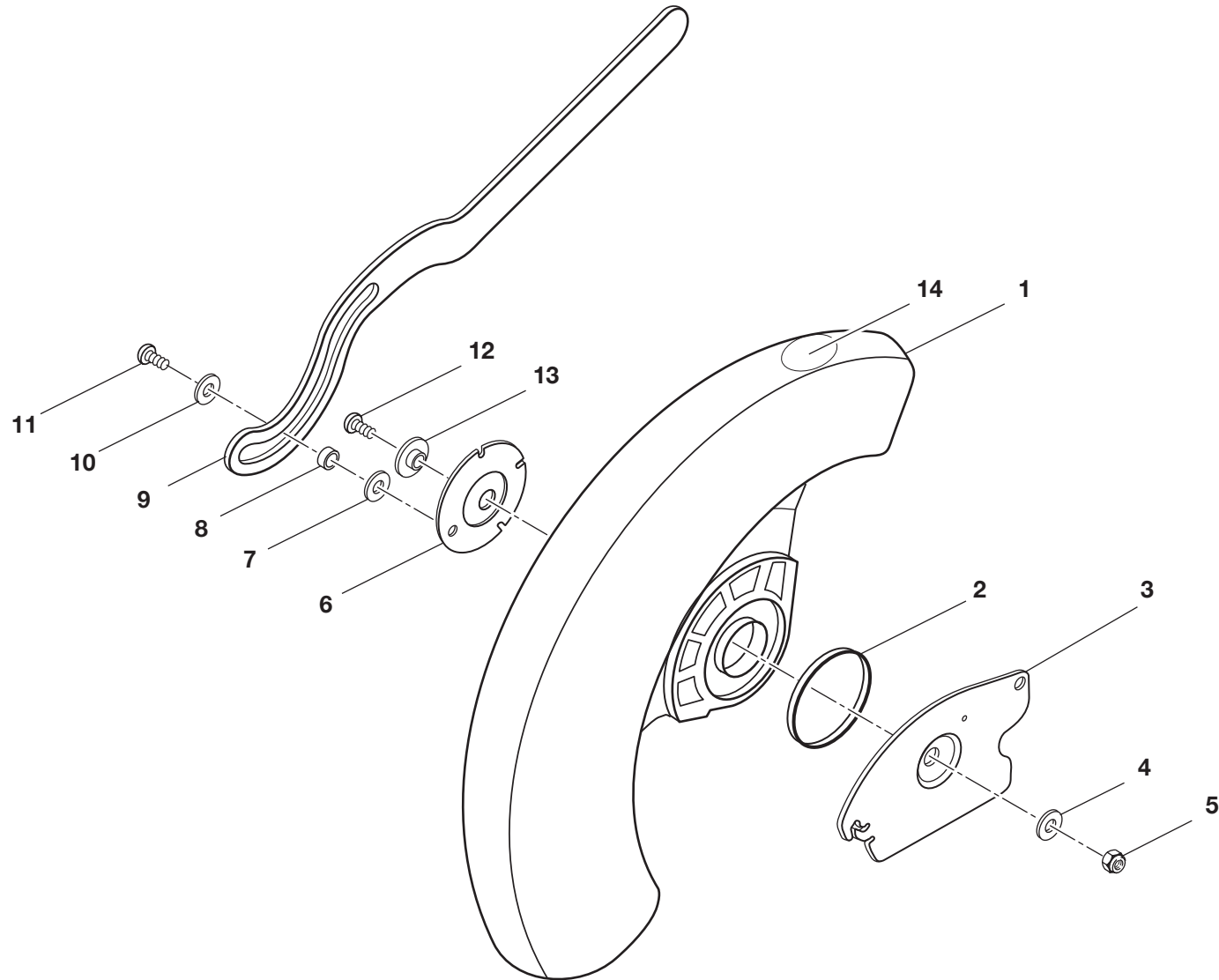

## RIDGID 12 in. SLIDING COMPOUND MITER SAW – MODEL NUMBER MS1290LZ

The model number will be found on a plate attached to the motor housing. Always mention the model number in all correspondence regarding your **MITER SAW** or when ordering repair parts.

### PARTS LIST FOR FIGURE I

Key No.	Part Number	Description	Qty.
1	830530	LOWER GUARD .....	1
2	816677	GUARD SPRING.....	1
3	830529	LOWER GUARD PIVOT .....	1
4	820238-8	WASHER.....	1
5	817449-1	LOCK NUT (M6 X 1.0).....	1
6	826879	GUARD RETAINER .....	1
7	820732-2	WASHER.....	1
8	820725-01	SPACER.....	1
9	830041	ACTUATOR LINK.....	1
10	820732-1	WASHER.....	1
11	820724	SCREW (M5 SHOULDER) .....	1
12	828142	SCREW (M6 X 1.0-13 mm FLAT HD).....	1
13	827409	BEARING RETAINER .....	1
14	867227001	NO HANDS WARNING LABEL .....	1

FIGURE J

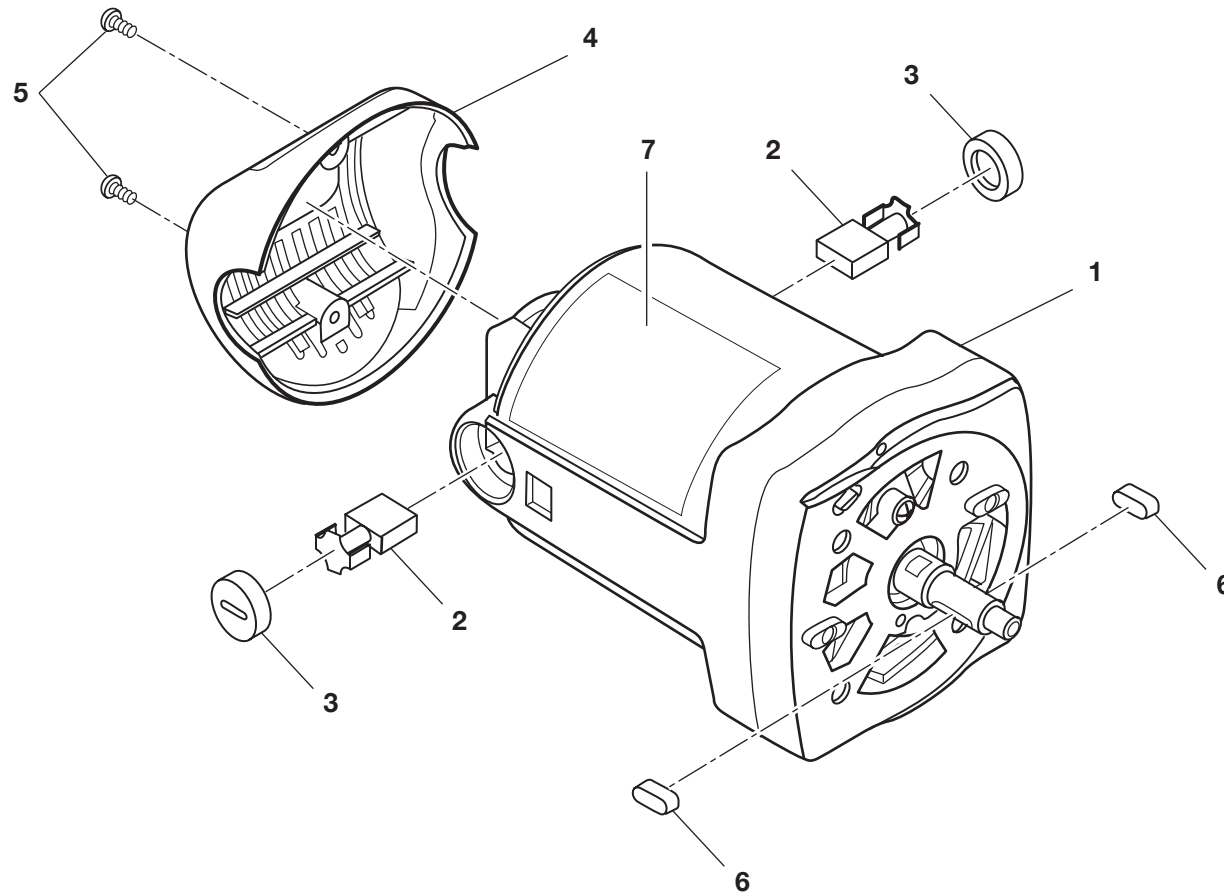

**RIDGID 12 in. SLIDING COMPOUND MITER SAW – MODEL NUMBER MS1290LZ**

The model number will be found on a plate attached to the motor housing. Always mention the model number in all correspondence regarding your **MITER SAW** or when ordering repair parts.

**PARTS LIST FOR FIGURE J**

<b>Key No.</b>	<b>Part Number</b>	<b>Description</b>	<b>Qty.</b>
1	830253	MOTOR.....	1
2	816768	BRUSH .....	2
3	830250	BRUSH COVER .....	2
4	828064	REAR MOTOR COVER.....	1
5	828122-1	SCREW (M4 X 10 mm PAN HD) .....	2
6	830027	KEY.....	2
7	867226013	WARNING LABEL (ENG.) .....	1