

HITACHI STAPLER (NARROW CROWN) Model N 3804AB

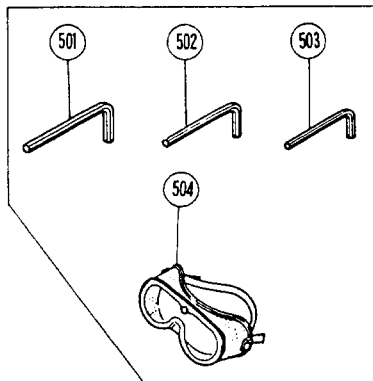
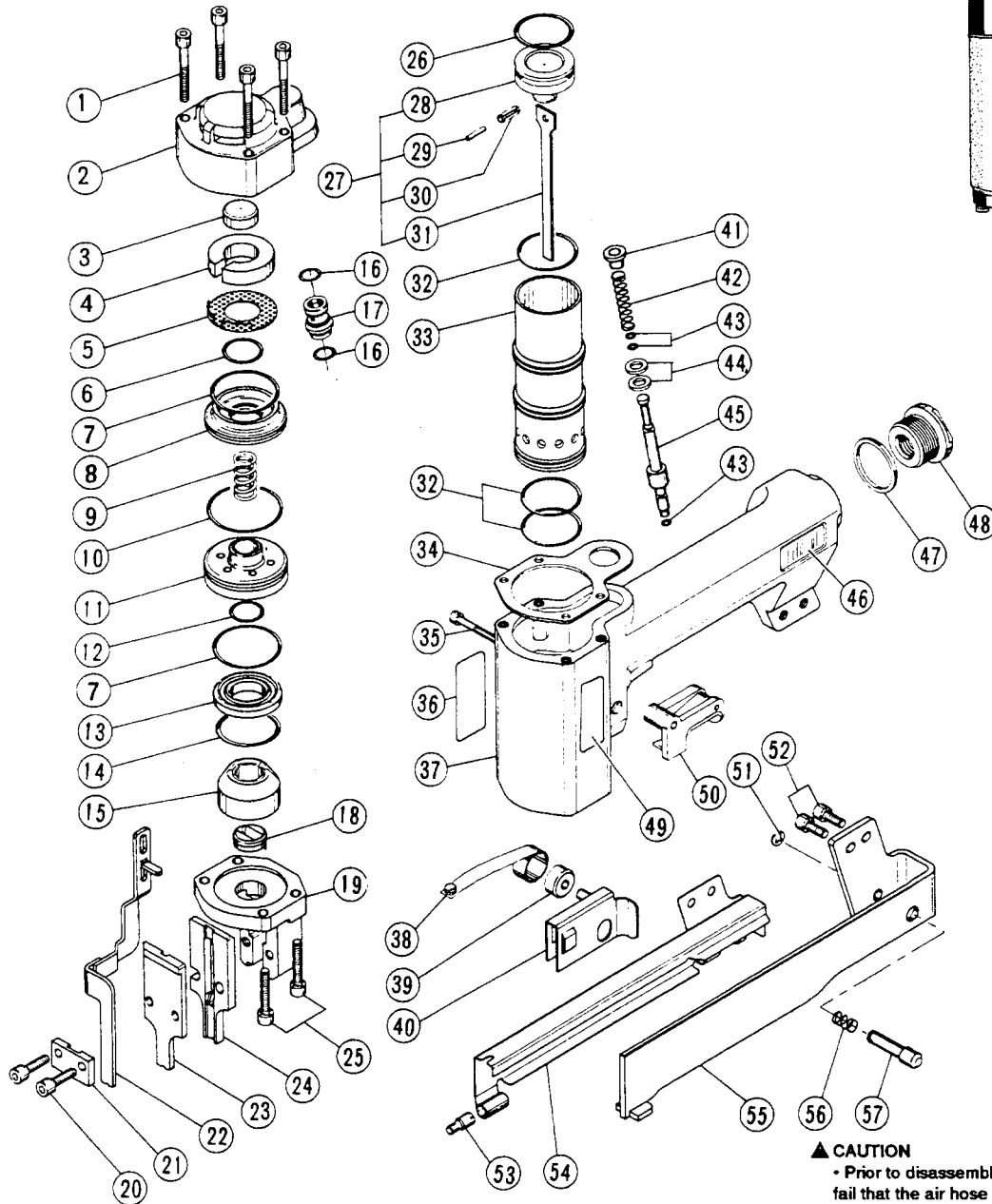
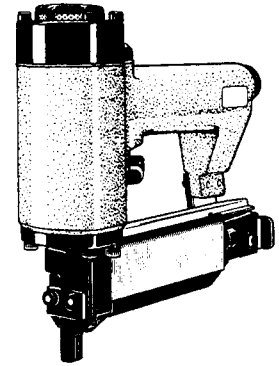

▲ CAUTION

- Prior to disassembly/reassembly, ensure without fail that the air hose is disconnected from the tool (while keeping your finger away from the trigger), and that the compressed air is completely discharged from the tool).

IMPORTANT - To assure product SAFETY and RELIABILITY, repairs, maintenance or adjustments should be performed by HITACHI Service Centers or other qualified service organizations. Always use HITACHI replacement parts.

Tightening Torque of each Bolts:

- M6 HEX. SOCKET HD. BOLT.....113 ± 7.0 lbs - in.
- M5 HEX. SOCKET HD. BOLT..... 74 ± 4.3 lbs - in.
- M4 HEX. SOCKET HD. BOLT..... 39 ± 2.8 lbs - in.
- M3 HEX. SOCKET HD. BOLT..... 22 ± 2.6 lbs - in.

HITACHI STAPLER (NARROW CROWN) Model N 3804AB

ITEM NO.	PART NO.	NO. USED	DESCRIPTION	SUPPLY Q'TY	ITEM NO.	PART NO.	NO. USED	DESCRIPTION	SUPPLY Q'TY
1	790 - 200	4	HEX. SOCKET HD. BOLT M5 x 35		33	790 - 232	1	CYLINDER	
2	790 - 201	1	EXHAUST COVER		34	790 - 233	1	GASKET	
3	790 - 202	1	GASKET		35	790 - 234	1	HEX. SOCKET HD. BOLT M4 x 30	
4	790 - 203	1	SILENCER		36	790 - 244	1	WARNING LABEL	
5	790 - 204	1	PERFORATED PLATE		37	790 - 235	1	BODY (INCLUD 36, 46, 49)	
6	790 - 205	1	O - RING (I. D. 15.6)		38	790 - 246	1	RIBBON SPRING	
7	790 - 206	2	O - RING (I. D. 33.05)		39	790 - 249	1	SPOOL	
8	790 - 207	1	DISC		40	790 - 250	1	STAPLE FEEDER	
9	790 - 208	1	VALVE SPRING		41	790 - 239	1	SLEEVE	
10	790 - 209	1	O - RING (I. D. 37.82)		42	790 - 240	1	VALVE SPRING (INCLUD 2PCS. WASHER)	
11	790 - 210	1	MAIN VALVE		43	790 - 241	3	O - RING (I. D. 2.57)	
12	790 - 211	1	O - RING (I. D. 14)		44	790 - 247	2	WASHER	
13	790 - 212	1	VALVE RING		45	790 - 242	1	VALVE SHAFT	
14	790 - 213	1	O - RING (I. D. 28.64)		46	-----	1	HITACHI LABEL	
15	790 - 214	1	PISTON BUMPER		47	790 - 238	1	GASKET	
16	790 - 230	2	O - RING (I. D. 7.65)		48	790 - 237	1	CAP	
17	790 - 231	1	VALVE BUSH		49	790 - 245	1	NAME PLATE	
18	790 - 215	1	DRIVER GUIDE		50	790 - 243	1	TRIGGER ASSY	
19	790 - 216	1	NOSE		51	790 - 254	1	CIRCLIP	
20	790 - 222	2	HEX. SOCKET HD. BOLT M5 x 18		52	790 - 252	2	HEX. SOCKET HD. BOLT M5 x 12	
21	790 - 221	1	BRIDGE PIECE		53	790 - 257	1	SCREW	
22	790 - 220	1	PUSH LEVER		54	790 - 251	1	COVER	
23	790 - 219	1	FRONT NOSE		55	790 - 253	1	STAPLE GUIDE	
24	790 - 218	1	BACK NOSE		56	790 - 255	1	PRESSURE SPRING	
25	790 - 217	4	HEX. SOCKET HD. BOLT M5 x 25		57	790 - 256	1	FEEDER STOP	
26	790 - 223	1	O - RING (I. D. 25.07)		60	790 - 258	1	CARTON	
27	790 - 224	1	PISTON ASS'Y (INCLUD 28-31)		501	944 - 458	1	ALLEN WRENCH FOR M5 SCREW	
28	790 - 225	1	PISTON		502	944 - 458	1	ALLEN WRENC FOR M4 SCREW	
29	790 - 227	1	PIN		503	943 - 277	1	ALLEN WRENCH FOR M3 SCREW	
304	790 - 228	1	ROLL PIN D4 x 12		504	875 - 788	1	EYE PROTECTOR	
31	790 - 228	1	DRIVER BLADE						
32	790 - 229	3	O - RING (I. D. 29.87)						

* SUPPLY QTY : 1PCE UNLESS OTHERWISE SPECIFIED