

RIDGID

R860071B

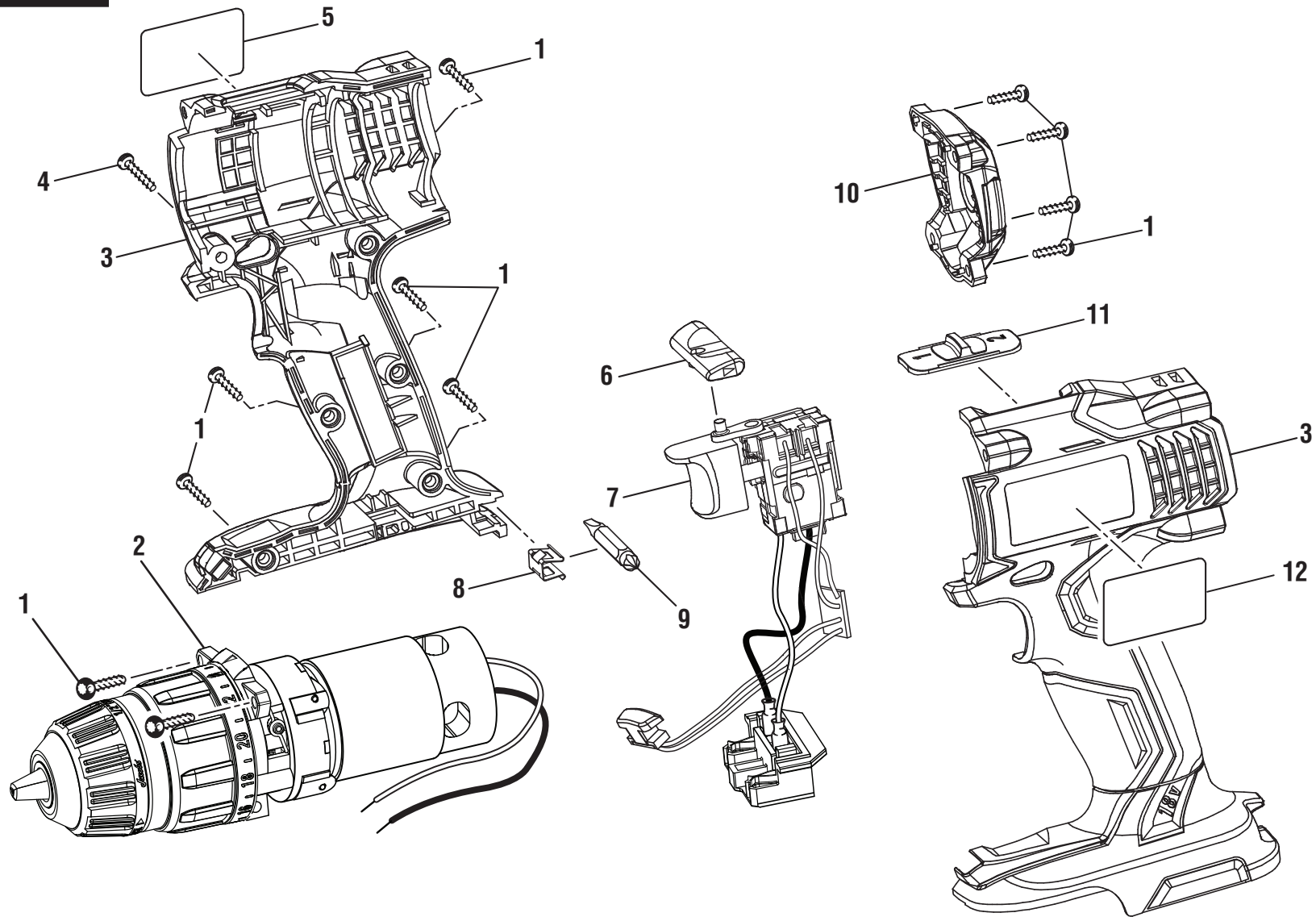

▲ **WARNING:** The assembly shown represents an important part of the Double Insulated System. To avoid the possibility of alteration or damage to the System, service should be performed by your nearest authorized service center.

▲ **AVERTISSEMENT :** L'ensemble illustré représente une partie importante du système à isolation double. Afin d'éviter la possibilité de modification ou de dommage au système, la réparation ne doit être effectuée que par votre centre de réparation centre commercial autorisé.

▲ **ADVERTENCIA:** El conjunto que se ilustra representa una parte importante del Sistema de Aislamiento Doble. Para evitar la posibilidad de alteración o daño del sistema, la reparación debe ser efectuada en su centro de servicio autorizado.



R860071B 18V Drill-Driver

KEY	P/N	DESCRIPTION	QTY
1	660024015	Screw (M4 x 14 mm, Pan Hd.)	11
2	210039003	Motor, Gear Train and Chuck Assembly	1
3	200868003	Housing Assembly	1
4	660024006	Screw (M4 x 22 mm)	1
5	940488079	Data Plate.....	1
6	517003001	Direction of Rotation Selector	1
7	270017412	Switch Assembly.....	1
8	6320601	Bit Clip.....	1
9	670820066	Double-Ended Bit.....	1
10	340002002	End Cap	1
11	340034001	Two-Speed Gear Selector.....	1
12	940114162	Logo Plate.....	1
NOT SHOWN:			
	987000022	Operator's Manual (R84008)	1
	987000205	Operator's Manual (R840091)	1
	988000038	Operator's Manual	1

4-30-10
(REV:02)

R860071B 18V Perceuse-tournevis

PIÈCE	RÉF.	DESCRIPTION	QTÉ
1	660024015	Vis (M4 x 14 mm, tête bombée).....	11
2	210039003	Moteur, engrenages et mandrin	1
3	200868003	Capuchon de boîtier.....	1
4	660024006	Vis (M4 x 22 mm).....	1
5	940488079	Plaque de données	1
6	517003001	Sélecteur de sens de rotation	1
7	270017412	Commutateur	1
8	6320601	Clip à embout.....	1
9	670820066	Embout double.....	1
10	340002002	Capuchon d'extrémité	1
11	340034001	Sélecteur de vitesse.....	1
12	940114162	Plaque de logo	1
NOT SHOWN:			
	987000022	Manuel d'utilisation (R84008).....	1
	987000205	Manuel d'utilisation (R840091).....	1
	988000038	Manuel d'utilisation	1

R860071B 18V Taladro-destornillador

REF.	N/P	DESCRIPCIÓN	CANT.
1	660024015	Tornillo (M4 x 14 mm, cab. trunc.)	11
2	210039003	Conjunto del motor, portabrocas y engranajes	1
3	200868003	Tapa del armazón	1
4	660024006	Tornillo (M4 x 22 mm)	1
5	940488079	Placa de datos.....	1
6	517003001	Selector de marcha adelante/atrás.....	1
7	270017412	Interruptor.....	1
8	6320601	Clip para la broca	1
9	670820066	Punta de destornillador doble.....	1
10	340002002	Tapa del extremo	1
11	340034001	Selector del engranajes de dos velocidades	1
12	940114162	Placa de logo.....	1
NOT SHOWN:			
	987000022	Manual del operador (R84008).....	1
	987000205	Manual del operador (R840091).....	1
	988000038	Manual del operador	1