

RYOBI ELECTRIC POWERHEAD – MODEL NOS. RY15122 and RY15123

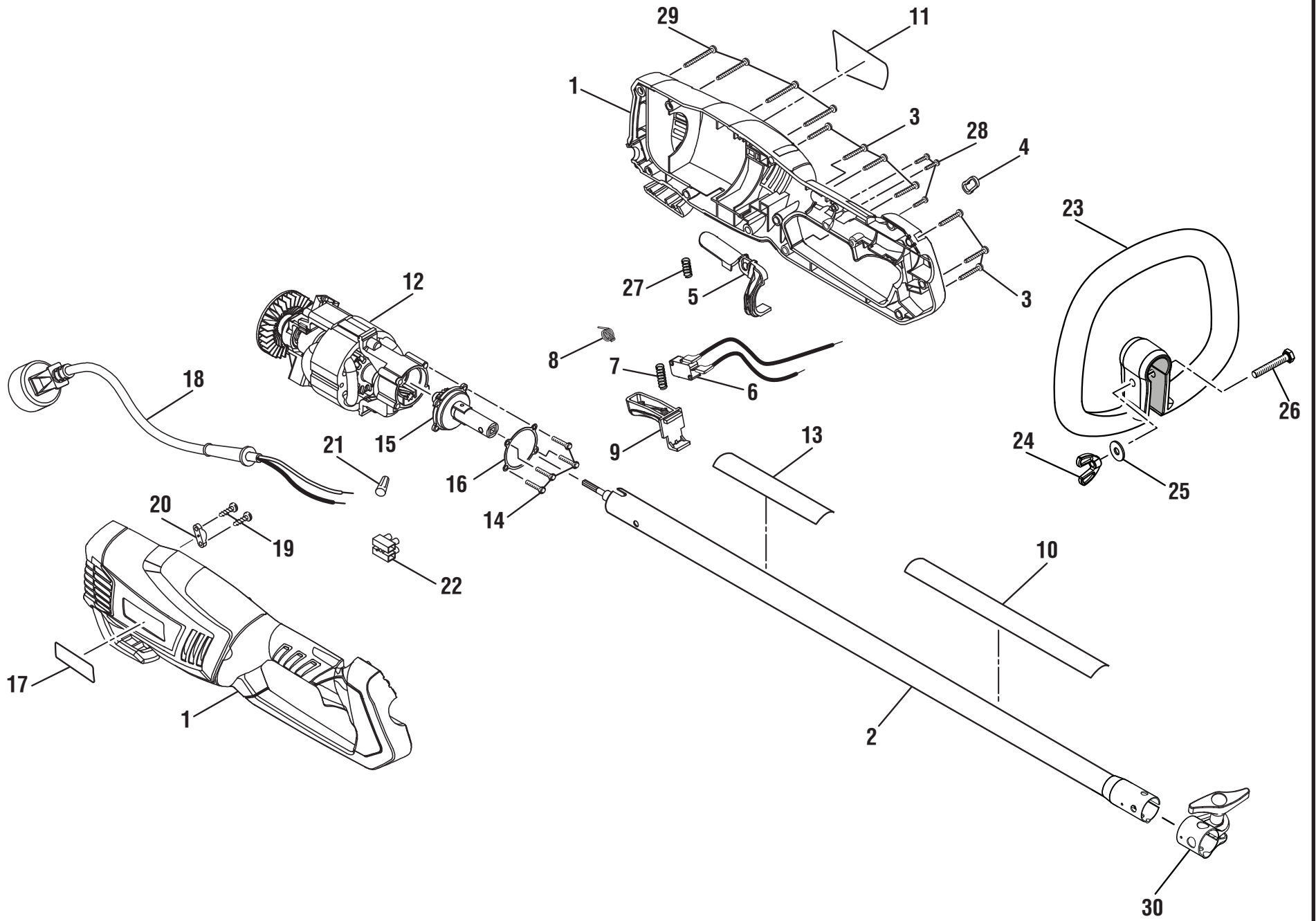

FIGURE A

RYOBI ELECTRIC POWERHEAD – MODEL NOS. RY15122 and RY15123

The model number will be found on a label attached to the motor housing. Always mention the model number of your **ELECTRIC POWERHEAD** when requesting service or ordering repair parts.

PARTS LIST

KEY NO.	PART NUMBER	DESCRIPTION	QTY	KEY NO.	PART NUMBER	DESCRIPTION	QTY
1	31301511G	Housing Assembly (RY15122).....	1	15	31105511G	Gear Assembly.....	1
	31301511AG	Housing Assembly (RY15123).....	1	16	34201511G	Rubber Gasket.....	1
2	31107511G	Boom Assembly (RY15122).....	1	17	099627001003	Logo Label.....	1
	31107511AG	Boom Assembly (RY15123).....	1	18	31102511G	Power Cord Assembly.....	1
3	3220313G	Screw (M4 x 14 mm).....	7	19	3220345G	Screw (M3.5 x 12 mm).....	2
4	33301511G	Strap Hook.....	1	20	3410801G	Cord Clamp.....	1
5	34101511G	Lock-Out Lever (RY15122).....	1	21	36504161G	Wire Nut.....	1
	34101511AG	Lock-Out Lever (RY15123).....	1	22	36404167G	Terminal Block.....	1
6	31109511G	Switch Assembly w/Leads.....	1	23	308991001	Front Handle Assembly (Inc. Key Nos. 24-26).....	1
7	33904511G	Compression Spring.....	1	24	34104511G	Wing Nut (1/4-20).....	1
8	33901511G	Torsion Spring.....	1	25	678008001	Washer (1/4 in.).....	1
9	34102511G	Switch Trigger (RY15122).....	1	26	660643008	Bolt (1/4-20 x 40 mm).....	1
	34102511AG	Switch Trigger (RY15123).....	1	27	33902511G	Compression Spring.....	1
10	099919001902	Warning Label (French).....	1	28	32202301G	Screw (M2.9 x 10 mm).....	3
11	099919001901	Data Label/Warning Label (English and Spanish, RY15122).....	1	29	3220106G	Screw (M4 x 18 mm).....	4
	099919002900	Data Label/Warning Label (English and Spanish, RY15123).....	1	30	UP03839A	Boom Clamp Assembly (RY15122).....	1
12	36101511G	Motor Assembly.....	1		34108511AG	Boom Clamp Assembly (RY15123).....	1
13	099919001900	Icon Strip Label.....	1	NOT SHOWN:			
14	3220205G	Screw (M4 x 10 mm).....	4	988000309	Operator's Manual		
				3-22-11 (Rev:02)			

WARNING: Improper repair of a double insulated tool can result in damage to the double insulation system possibly causing electrical shock or electrocution. Any repairs requiring disassembly of your tool requires safety testing and should only be performed by a Ryobi Authorized Service Center. For the service center nearest you call 1-800-525-2579.