

RYOBI 15 in. LINE TRIMMER – MODEL NUMBER RY41002A

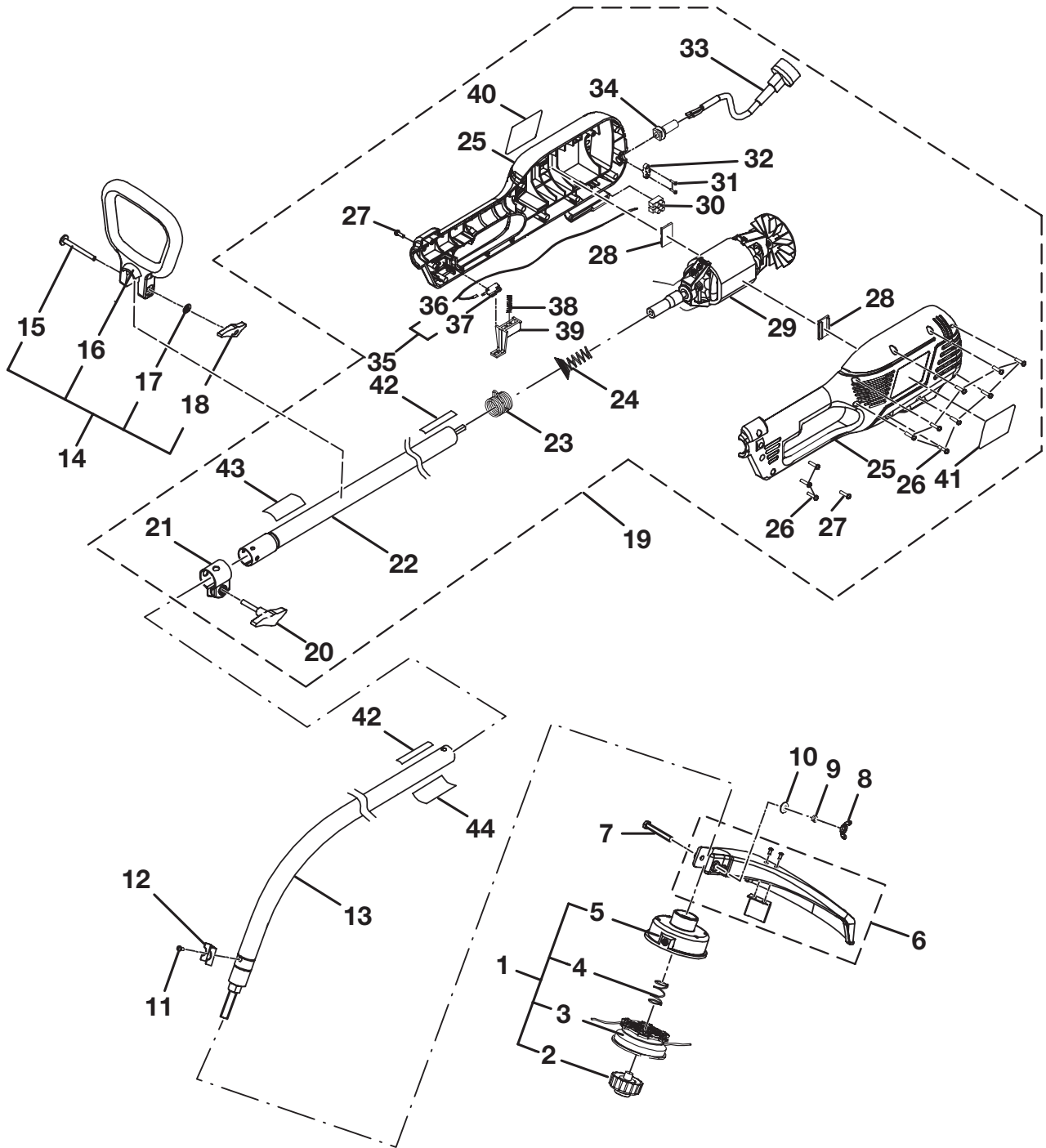

WARNING: Improper repair of a double insulated tool can result in damage to the double insulation system possibly causing electrical shock or electrocution. Any repairs requiring disassembly of your tool requires safety testing and should only be performed by a Ryobi Authorized Service Center. For the service center nearest you call 1-800-525-2579.

RYOBI 15 in. LINE TRIMMER – MODEL NUMBER RY41002A

The model number will be found on a plate attached to the motor housing. Always mention the model number in all correspondence regarding your **LINE TRIMMER** or when ordering repair parts.

PARTS LIST

KEY NO.	PART NUMBER	DESCRIPTION	QTY.
1	099081003001	STRING HEAD ASSEMBLY	1
2	099081003002	RETAINING CAP ASSEMBLY	1
3	099081003003	SPOOL	1
4	099081003004	COMPRESSION SPRING.....	1
5	099081003005	TRIMME HEAD ASSEMBLY.....	1
6	099081003006	GRASS DEFLECTOR ASSEMBLE	1
7	099015002004	HEX BOLT	1
8	099015002005	WING NUT	1
9	099081003009	SPRING WASHER.....	1
10	099081003010	WASHER	1
11	099081003012	* SCREW (M5 X 8)	1
12	099081003013	BRACKET	1
13	099081003014	LOWER DRIVESHAFT HOUSING ASSEMBLY	1
14	099081003018	AUXILARY HANDLE ASSEMBLY	1
15	099081003019	CARRIAGE BOLT	1
16	099081003020	FRONT HANDLE	1
17	099081003021	FLAT WASHER.....	1
18	099081003022	LOCK KNOB	1
19	099015003010	DRIVER UNIT (INC. KEY NOS. 20-43)	1
20	099015002006	KNOB (EXPAND-IT COUPLER)	1
21	099015002007	EXPAND-IT COUPLER.....	1
22	099015003011	UPPER DRIVE SHAFT HOUSING ASSEMBLY	1
23	099081003023	HOOK	1
24	099081003037	SPRING	1
25	099015003001	HOUSING ASSEMBLY.....	1
26	099081003028	* SCREW (M4 X 18)	11
27	099081003027	SCREW	2
28	099081003033	RUBBER CUSHION	2
29	099015003006	MOTOR KIT.....	1
30	099081003032	CONNECTOR ASSEMBLY.....	1
31	099015002010	* SCREW (M4 X 15)	2
32	099081003031	CORD CLAMP.....	1
33	099015002009	POWER CORD & PLUG	1
34	099081003029	STRAIN RELIEF	1
35	099015003004	SWITCH ASSEMBLY	1
36	099015003013	CONNECTED WIRE	1
37	099015003012	SWITCH	1
38	099081003035	COMPRESSION SPRING	1
39	099015003005	TRIGGER.....	1
40	099015003007	RATING LABEL	1
41	099015002018	LOGO LABEL (ON LEFT HOUSING)	1
42	099015002014	ICON WARNING LABEL	2
43	099015002015	WARNING LABEL	1
44	099015002016	LOWER BOOM WARNING LABEL	1
	099015003014	CONVERSION KIT (INC. KEY NOS. 25, 29, 35, 39, AND 40). 1	
	983000841	OPERATING MANUAL (099015003009)	
	983000841R	REPAIR SHEET (REV:00)	
	10-23-05		

* Standard Hardware Item – May Be Purchased Locally